



RT3TM SLIDER camera



The **RT3** Slider digital camera system affords the ultimate flexibility to researchers by combining both monochrome and color capability in one camera. The **RT3** Slider is the newest camera version from the popular RT line of cameras, and delivers improved performance in a number of areas.

The **RT3** Slider camera is a 14-bit camera featuring high speed FireWire connectivity. With an effective differential cooling of -43°C , this camera provides significant performance for long exposure fluorescence imaging by reducing dark current to below 0.03 e/p/s. Easily switch the slider to color and get exceptional color images through the application of ICC color profiling standards.

The **RT3** Slider boasts reduced read noise, providing higher dynamic range when combined with the deep pixel wells of its Kodak KAI 2020 CCD. Frame capture rates have been tripled when compared with its predecessor.

RT3 DIMENSIONS

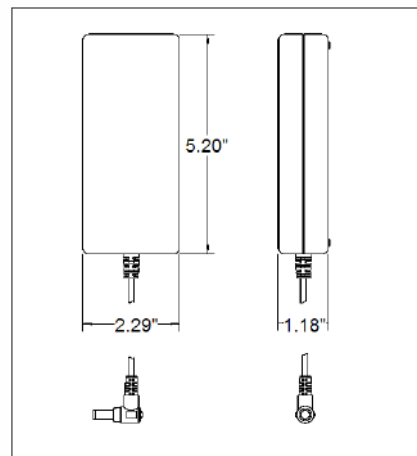
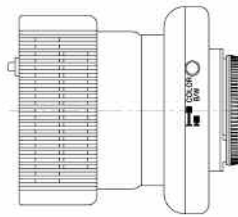
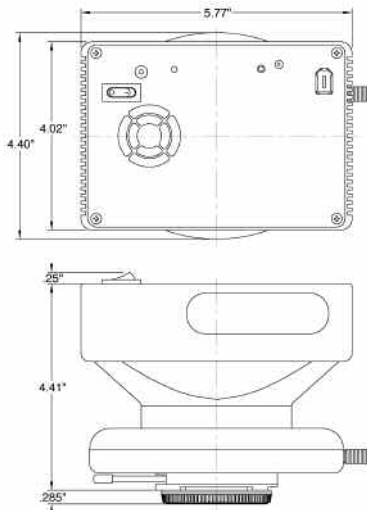

RT3 POWER SUPPLY

CAMERA FEATURES

- CCD cooled to -43.3°C below ambient
- 1600 x 1200 (1.92 Mpixel) image capture
 - Programmable gain (1-16x)
 - 14 bit x 20 MHz capture
- 40 MHz live mode (dual channel 20 MHz)
 - Interline progressive scan CCD
 - FireWire[®] interface

SPOTTM Software
Mac[®] & Windows[®] operating systems
Basic & Advance applications
Twain & Apple Event
DLL w/ SDK and tutorial manual
3rd party driver support

Reduces dark noise for long exposure image capture

Resolves fine detail

Facilitates live mode previews of low light specimens

Extra bit depth is ideal for image enhancement

High-speed imaging for real time viewing

Electronic shuttering eliminates mechanical shutter shortcomings related to speed, wear, and vibration

Allows for effortless installation, hot-swapping, and laptop connectivity for greater ease of use

Provides essential tools for modern microscopy and is widely supported by 3rd party software companies for high end applications as well as providing DLL with SDK for OEM Driver development

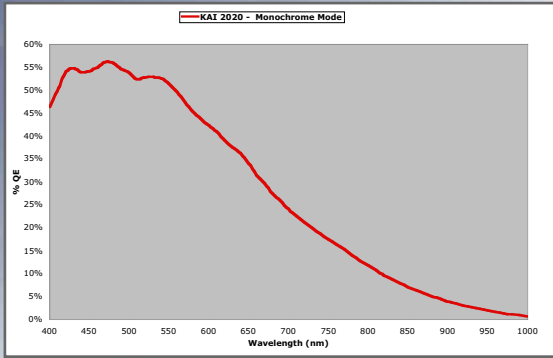

CCD INFORMATION

Kodak KAI-2020-M with cover glass
 Monochrome progressive scan interline CCD
 1600 x 1200, 7.4 μ m square pixels
 11.8mm x 8.9 mm active area, 14.8 mm diagonal
 100x minimum anti-blooming

COOLING

-43.3°C differential from ambient via thermoelectric cooler
 with fan cooled heat sink (-23.3°C from an ambient of 20°C)

DIGITIZATION INFORMATION

Digitized pixel by pixel at CCD sensor
 Live mode: 8 bit x 40 MHz (Dual channel 8 bit x 20 MHz)
 Live image frame rate: 18 frames per second
 Capture mode: 14 bit x 20 MHz (see chart for frame rate)
 A/D Converter full scale set to 31,500 e (Gain=1)
 Saved bit depths: 8, 12, 14 or 16 bit BW

READ NOISE SPECIFICATIONS

Read noise: 16 e- rms
 Dark current: 0.003 e/p/s (typical)

EXPOSURE

0.5 ms to 286 minutes; captured and live mode automatic
 exposure; captured and live mode manual exposure

LENS MOUNT

F-mount

SEALING WINDOW

Corning 7980 fused silica
 320 nm–820 nm anti-reflection coating

COMPUTER INTERFACE

FireWire (IEEE 1394a)

INPUT/OUTPUT

External device control: TTL level output
 with programmable delay

External trigger input: TTL level input

MECHANICAL

Tripod mount: 1/4 - 20 UNC
Camera head: 5.77" (147 mm) x 4.02" (102 mm)
 x 3.15" (80 mm), 2.4 lbs. (1.09 kg)
Power supply: 2.29" (58 mm) x 5.20" (132 mm)
 x 1.18" (30 mm), 0.70 lbs. (0.32 kg)

Binning	Captured image/Frame rate*				
	1600x1200	1024x1024	512x512	256x256	50x50
1x1	7.6	8.9	16.0	26.7	58.2
2x2	13.8	15.8	26.2	38.6	63.4
3x3	18.7	20.9	32.2	44.5	64.6
4x4	22.1	24.5	35.9	46.2	60.6
8x8	27.9	29.6	37.0	41.4	40.9

*0.5 ms exposure with post-processing deferred, taken with 1.67 GHz
 AMD XP2000 processor running Windows XP monochrome mode.
 Other platforms may provide different results.

Operating environment: 0 to 30°C ambient, 0-80%
 relative humidity noncondensing

Power requirements: 100-240 VAC, 1.5A

CERTIFICATIONS

CE, FCC Class A, EN60950, RoHS compliant

SPOT SOFTWARE FEATURES

Live mode viewing window & controls, auto-exposure live
 and capture modes, image capture window, predefined
 and custom image setups, auto white balance, flat field
 correction, image enhancement tools in three color
 spaces (RGB, HSL, HSV), pan and zoom windows,
 multiple customizable floating taskbars, spot metering,
 non-destructive annotations, non-destructive calibration
 marks, measurement tools, sequential image capture and
 playback, exportable image archiving database (PC only),
 report generator, macro scripting, peripheral device
 control, interactive print dialog, online help menu, and
 Correct Color Technology™.

FILE FORMATS

BMP, TIFF, TIFF-JPEG, JPEG, JPEG-2000, PICT, AVI

TIFF FILE SIZES

8 bit BW / 1.83MB • 12 bit BW / 2.75 MB
 16 bit BW / 3.66 MB

DRIVERS INCLUDED

Twain for supported Windows® operating systems
 AppleEvent for supported Mac® operating systems

3RD PARTY SOFTWARE

Call or visit our website (www.diaginc.com)

MINIMUM SYSTEM REQUIREMENTS

PC: Pentium 400 Mhz or greater with Windows
 98 SE, 2000, ME, or XP, 512 MB of RAM, Firewire/IEEE
 1394a interface* **Mac:** Power PC G4 or greater with OS 10.3.9
 or higher, 512 MB of RAM, Firewire/IEEE 1394a interface.
 Video card: 24 bit RGB @ desired resolution

Items included: Camera head, FireWire® data cable (6-pin), power supply
 cable, power supply, power cord, SPOT software install CD (includes
 drivers), software user guide, hardware user guide, 2 year warranty

*Desktop computers may require IEEE 1394a to PCI bus interface card, laptop computers may require IEEE
 1394a to PCMCIA interface card FireWire® and Mac® are registered trademarks of Apple Computers, Inc.
 Windows® is a registered trademark of Microsoft. Specifications are typical and subject to change.
 All specified performance is typical, unless noted otherwise.

RT-3: Catalog #RT2540 9.21.06

Diagnostic Instruments, Inc.
 6540 Burroughs Street
 Sterling Heights, MI 48314
 586.731.6000 • www.diaginc.com

