

H138 Stage

9"x3" Travel, Programmable, Motorized Stepper Stage for Upright Microscopes

Features



Increase your specimen handling and speed efficiency with the H138 motorized stage from Prior Scientific. The H138 stage allows you to work more productively by having the capability to load up to eight 1"x3" specimen slides onto one stage and processing them together. Sample holders can be released quickly and easily interchanged to increase processing speed. The stage also allows you to also scan specimens that won't fit on standard sized stages. The H138 features:

- Travel of 240mm x 71 mm (9" x 3")
- Repeatability to ± 1.0 micron
- Step size (resolution) of the stage is from 0.02 microns, depending on the controller configuration
- Stages customized to any microscope or mount
 - Stage insert for eight slides

Prior stages have a well-deserved reputation for quality and repeatability. They are manufactured using the highest quality components: crossed roller ways, zero backlash recirculating ball screws, X and Y limit switches, two high precision stepper motors even a tough scratch resistant coating. They are available with standard and custom sample holders to suit the user's application and requirements. Stages can be driven by the Prior series of motor controllers or compatible systems in existing OEM configurations. The controller can be accessed via RS-232 serial port/USB or with an optional joystick or keyboard. For the H138 and all its products, Prior provides full support and service both direct and indirect – through a professional, knowledgeable and extensive dealer network.

H138 Stage



9"x3" Travel, Programmable, Motorized Stepper Stage for Eight Slides or Large Samples

Standard Sample Holders

500-H238	Eight Slide Holder
500-H239	Solid Aluminum Plate
500-H288	Glass Plate

Custom Samples are available upon request

Ordering Information

Stage:

500-H138ANNN	9"x3" travel stage
500-H138ANNI	9"x3" travel stage, with 0.1 μm linear scales

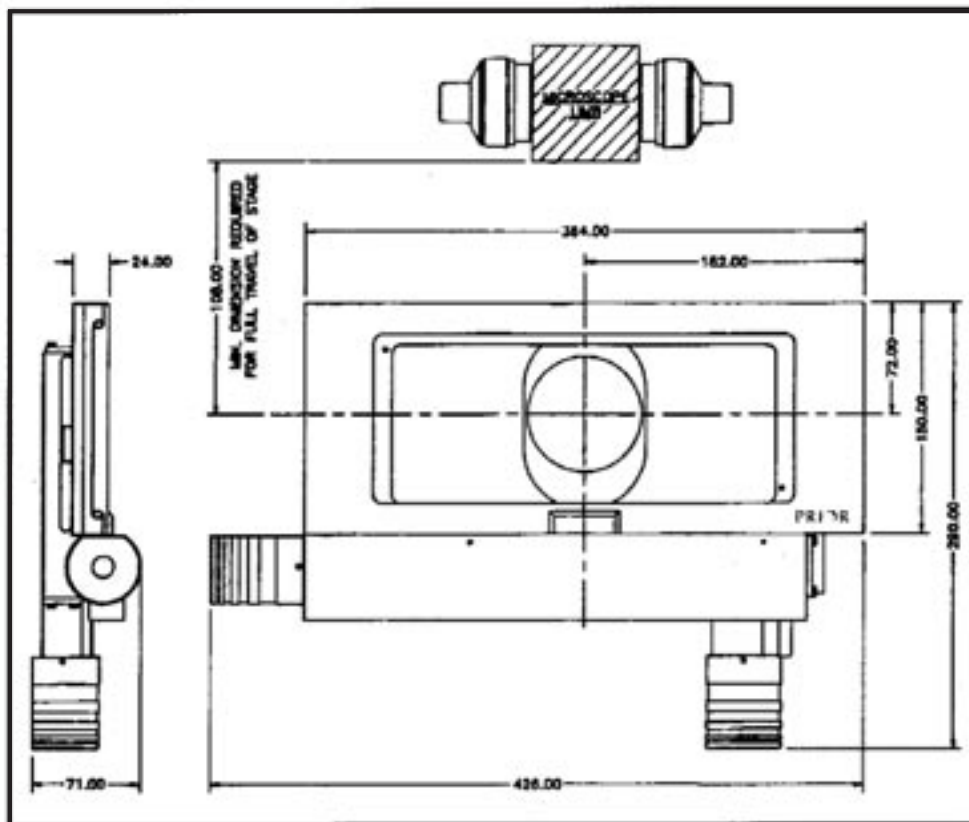

Dimensions in millimeters.

General Specifications

Travel Range

240 mm x 71 mm (9" x 3")

Repeatability*

$\pm 1 \mu\text{m}$ (micrometer)

Minimum Step Size (Resolution)

0.02 μm

Load Capacity

10 kg (22 lbs)

Stepper Motor

4 phase, 1 amp per phase, micro stepping

Linear Slides

Crossed 3 mm roller bearings

Drive Screws

Zero backlash, recirculating ball screws; 2 mm pitch standard

Limit Switches

X and Y standard

Stage Profile

Approximately 25 mm (1.0") with glass plate installed

Weight

4.0 kg (8.8 lbs)

Finish

Electro-phoretic black plate

* Specifications valid only if used with Prior controller.

PRIOR
Scientific

PRIOR SCIENTIFIC INSTRUMENTS LIMITED,
UNIT 4, WILBRAHAM ROAD, FULBOURN,
CAMBRIDGE CB1 5ET
TELEPHONE 01223 881711
FAX 01223 881710

PRIOR SCIENTIFIC INC.,
80 RESERVOIR PARK DRIVE,
ROCKLAND, MA 02370-1062
TELEPHONE 781-878-8442
FAX 781-878-8736

VISIT PRIOR ON THE WEB AT www.prior.com

Specifications subject to change without notice.