



Leica DMI 6000 B

Modular System
Stands, Modules and Accessories

Leica
MICROSYSTEMS

Leica DMI 6000 B Modular System

Issued: October 2004

Contents

Leica DMI 6000 B – Basic Stand	page 3
Leica DMI 6000 B – Base Stand	page 5
Observation and Documentation Tubes	page 9
Stages and Specimen Holders	page 12
Transmitted Illumination	page 19
Condensers and Accessories	page 20
Integrated Modulation Contrast and Integrated Positive and Negative Phase Contrast	page 25
Transmitted Light Polarization Contrast	page 27
Transmitted Light Differential Interference Contrast	page 28
Incident Illumination for Bio-fluorescent Systems	page 32
Light Sources, Lamp Housing, Supply Units	page 37
TV Adapter	page 40
Objectives, Objective Turret, Optics	page 41
Accessories	page 45
Micromanipulator	page 46
Control Units for Heating Stages and Incubators	page 47
CO ₂ Incubation	page 48
Dimensions and Weights	page 49
Technical Data	page 49
System Overview	page 50

Published October 2004

Leica Microsystems Wetzlar GmbH
Ernst-Leitz-Straße
D-35578 Wetzlar (Germany)

Responsible for contents:
Bernard Kleine
(Marketing CM, Compound Microscopy, Product Management)
Holger Grasse
(Safety Officer according to MPG §30)

For questions, please contact the hotline:
Tel. +49(0)6441-292286
Fax +49(0)6441-292255
Email: MQM-Hotline@leica-microsystems.com

Leica DMI 6000 B – Basic Stand

The Leica DMI 6000 B is a further development of Leica's proven line of inverted research microscopes. It is designed for cellular and tissue examination, micromanipulation and microinjection techniques, microdissection, and confocal microscopy. The Leica DMI 6000 B is suitable for universal deployment. All contrast methods such as darkfield, brightfield, phase contrast, DIC, fluorescence, and modulation contrast are integral to the microscope and can be adapted or changed quickly and easily. Variable illumination and imaging beam paths, as well as HCS optics, modular accessories, and a comprehensive range of peripherals complement the Leica DMI 6000 B inverted research stand.

Basic Stand

The basic stand is the solid foundation of the microscope. It includes the focusing system, objective turret, stage mount, mounts for incident and transmitted light units, an LCD screen for status information, and a variety of buttons for motorized functions such as magnification, camera ports, fluorescence and transmitted light filters, and contrast methods. A variety of interfaces for PCs as well as internal and external peripheral devices are located on the back of the basic stand.

By selecting from a range of modules such as light sources, objectives, eyepieces, tubes, stages, filters, and incident and transmitted light components, the user can assemble a personal, application-specific microscope system.

The system diagram (see page 50) provides a good overview of this modular system. Leica Microsystems representatives can provide effective support to configure an optimal system for specific user requirements via Leica's PC-based configuration system. In addition, Leica's applications specialists can help with specific questions.

Because of its modular design principle, the Leica DMI 6000 B microscope system can be modified and extended to suit changing requirements at any time.

Ergonomic considerations were given a high priority in all of the stand designs, such as the convenient positioning of important controls and the availability of Ergomodules or ergonomic component sizes.

The massive, functional, and rugged design of the stands ensure ease of use and image stability over the course of the application, right up to the highest magnification.

Optics of the highest standards ensure brilliant images with high contrast and resolution for any conceivable application.

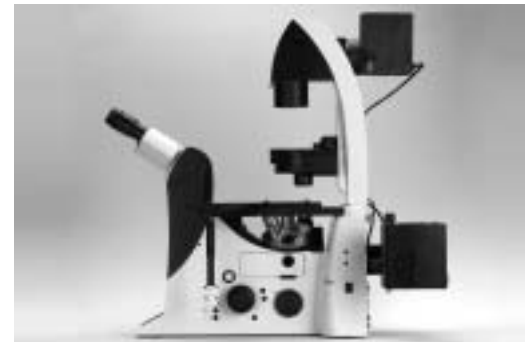

Fig. 1: Right side of stand



Fig. 2: Left side of stand



Fig. 3: Leica CTR6000 electronics box



Fig. 4: Front view of stand



Fig. 5: Leica SmartMove

8 basic stands are available for the Leica DMI 6000 B. These basic stands essentially differ in their options for the adaptation of integrated modulation contrast and the provisions for camera ports at the tube or the bottom of the stands.

Stand	Order Number
DMI 6000 B basic stand with bottom port (ready for IMC* and top port)	11 888 284
DMI 6000 B basic stand without bottom port (ready for IMC* and top port)	11 888 285
DMI 6000 B basic stand with bottom port (without IMC* ready for top port)	11 888 286
DMI 6000 B basic stand without bottom port (without IMC* ready for top port)	11 888 287
DMI 6000 B basic stand with bottom port (ready for IMC* without top port)	11 888 288
DMI 6000 B basic stand without bottom port (ready for IMC* without top port)	11 888 289
DMI 6000 B basic stand with bottom port (without IMC* without top port)	11 888 290
Leica DMI 6000 B basic stand without bottom port (without IMC* without top port)	11 888 291

Bottom Port	IMC*	Top Port	Order Number
x	x	x	11 888 284
o	x	x	11 888 285
x	o	x	11 888 286
o	o	x	11 888 287
x	x	o	11 888 288
o	x	o	11 888 289
x	o	o	11 888 290
o	o	o	11 888 291

* Available: May 2005

Leica CTR6000 Electronics Box (Fig. 3 p. 4)

With built-in power supply 12 V 100 W, and for control of the automatic microscope functions. With RS 232 interface for PC connection, including RS 232 cable. AC power supply 90–250 V, 50–60 Hz 11 888 109

SmartMove (Fig. 5 p. 4)

x/y/z Ergo control panel for electronic focus (z) and motor stage (x/y). With 4 freely programmable function keys. 11 505 180

Leica DMI 6000 B – Base Stand

All basic stands are ready for these contrast methods:

- Brightfield
- Darkfield
- Phase contrast
- Polarization contrast
- Differential Interference Contrast (DIC)
- Integrated modulation contrast (11 888 284, 11 888 285, 11 888 288, 11 888 289 only)
- Integrated pos./neg. phase contrast (11 888 284, 11 888 285, 11 888 288, 11 888 289 only)
- Fluorescence
- Fluorescence – DIC combination contrast
- Fluorescence – Phase combination contrast

All basic stands are ready for these camera connections:

- Right camera port with (100%) and/or (80%) and/or (50%)
- Left camera port with (100%) and/or (80%) and/or (50%) and/or dichroic splitting at 680 nm
- Right and left camera port with (100%) and/or (80%) and/or (50%) and/or dichroic splitting at 680 nm
- Bottom port (11 888 284, 11 888 286, 11 888 288, 11 888 290 only) with (100%) and/or (50%) and/or (20%) and/or dichroic splitting at 680 nm (depending on right or left camera port)
- Top port (11 888 284, 11 888 285, 11 888 286, 11 888 287 only) with 100/0% and 50/50% eyepiece/port split

All basic stands are ready for these magnifications:

A motorized magnification changer with 1–3 different, freely-configurable magnification levels that affect all camera ports:

- 1.0x (always available)
- 1.5x
- 1.6x
- 2.0x

Alternatives:

All basic stands are ready for a manual magnification changer with two freely configurable magnification levels. This magnification changer affects only the top port and eyepieces:

- 1.0x (always available)
- 1.5x
- 1.6x
- 2.0x



Fig. 6: Top port

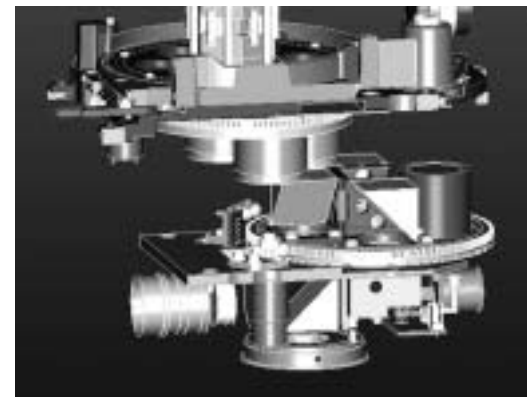

Fig. 7: Schematic representation of the 6-position fluorescence disk (1), magnification changer (2), side port module (3) and bottom port module (4)

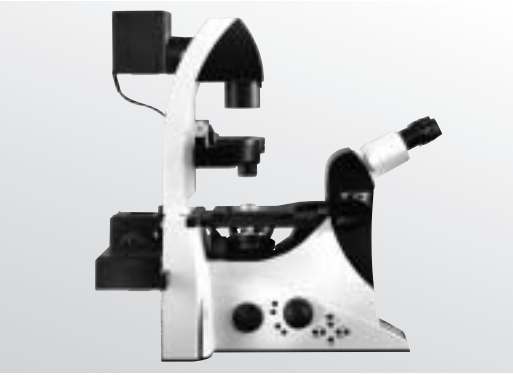

Fig. 8: Controls (left)

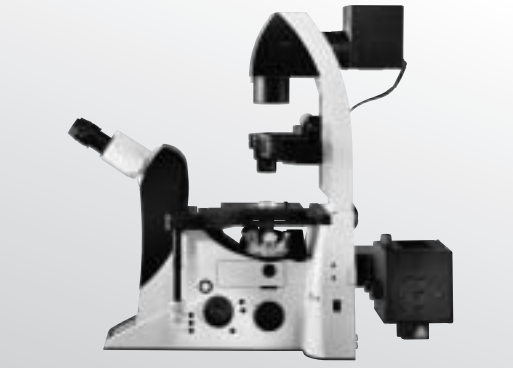

Fig. 9: Controls (right)



Fig. 10: Controls (front)



Fig. 11: Back panel

Controls

- 7 fixed control buttons for illumination and apertures
- 7 variable function buttons behind the focus controls
- 3 fixed control buttons for focus steps
- 2 focus hand wheels
- 7 buttons for fluorescence cubes and shutters
- 4 buttons for magnification changers and ports
- SmartMove: Ergonomic controller for x, y, z and 4 additional variable function buttons

Interfaces

- 2 x RS232C
- 2 x USB
- 4 x external/internal peripherals

Objective Turret

- Motorized and coded
- 6x for objectives with M25 thread and 45 mm parfocal distance
- For DIC: Motorized/coded Wollaston prism carousel
- Anti-vibration locking

Z Focus

- Motorized and coded
- 9mm travel (1 mm below, 8mm above the stage)
- 5 focus steps: 0.05 μm ; 0.1 μm ; 0.7 μm ; 1.5 μm ; 5.0 μm
- Electronic focus repositioning
- Automatic lowering prior to objective change
- Electronic parfocality

Tube

- Ergonomic with or without camera port at left
- 2 switching positions: 100% VIS and 50% VIS/50% CAM
- Optional Bertrand lens
- Eye spacing adjustment
- Height and angle adjustment (10° to 45°)

Optics

- Leica HCS infinity optics
- Tube factor 1x
- 25 mm field of view

Transmitted Light Axis

- Automatic illumination manager (aperture, field diaphragm, intensity, method switching)
- Automatic, color-neutral intensity control
- Manual or motorized shutter
- Lamp housing mount for interchangeable lamp housings
- Automatic, electronic condenser identification

Incident Light Axis

- Automatic illumination manager (aperture, field diaphragm, intensity, method switching)
- Automatic, color-neutral intensity control
- Motorized shutter (switching speed < 50 ms)
- Lamp housing mount for up to 3 interchangeable light sources
- Motorized 6-position filter disk
- Fluorescence Intensity Manager (FIM) (reduction of the light intensity of incident illumination)
- Mechanical booster lens for central boosting of fluorescence or for boosting uniform distribution
- Motorized Excitation Manager to monitor fluorescence emission when using double and triple filter cubes
- Ultrafast filter wheel for 3 excitation wavelengths (switching speed < 50 ms)

Stages

- Fixed regular stages
 - Ceramic-coated stage plate (248mm x 204mm)
 - Heated stage plate (3°C above room temperature to 60°C)
 - Temperature-controlled stage plate (0°C to 60°C) (248 mm x 212 mm)
- Fixed micromanipulation stages
 - Ceramic-coated stage plate (248 mm x 204/122 mm)
 - Heated stage plate (3°C above room temperature to 60°C) (248 mm x 204/122 mm)
 - Temperature-controlled stage plate (0°C to 60°C) (248 mm x 204/122 mm)
- Regular manual 3-plate cross-stage
 - Positioning range 83 mm x 127 mm
 - 20 optional inserts (standard, heating, cooling) for a variety of applications, size of inserts: 160 mm x 110 mm (compatible with scanning stages)
- Manual micromanipulation 3-plate cross-stage
 - Positioning range 40 mm x 40 mm
 - 3 optional inserts for a variety of applications
- Motorized micromanipulation 3-plate cross-stage
 - Positioning range 40 mm x 40 mm
- Scanning stage IM 120 x 100 (motors on top)
 - 1 mm, 2 mm, 4 mm spindle pitch (higher resolution vs. higher speed)
 - 20 optional inserts (standard, heating, cooling) for a variety of applications, size of inserts: 160 mm x 110 mm
- Scanning stage IM 120 x 100 (motors on bottom)
 - 1 mm, 2 mm, 4 mm spindle pitch (higher resolution vs. higher speed)
 - 20 optional inserts (standard, heating, cooling) for a variety of applications, size of inserts: 160 mm x 110 mm



Fig. 12: Transmitted-light axis

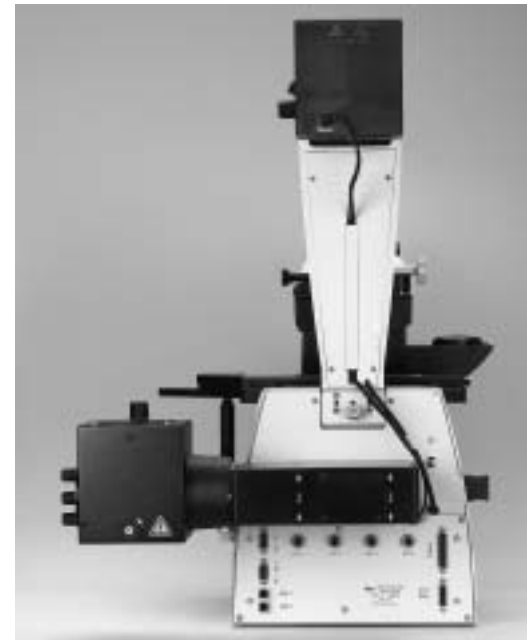

Fig. 13: Incident-light axis illumination



Fig. 14: Micromanipulation stage with attachable mechanical stage



Fig. 15: Screw cap



Fig. 16: DIC cover



Fig. 17: Analyzer opening cover



Fig. 18: Camera port cover

Screw cap for empty objective positions

Component of stand 11 020-422-580-028

Cover for unused objective DIC disk opening

Component of stand 11 090-144-020.088

Dust and light protection cover for polarizer opening

Component of stand 11 020-437-101-013

Dust and light protection cover for camera port openings

Component of stand 11 020-387-556-009

Ergonomic height compensation plate

A height compensation plate is available to raise the viewing height by 20 mm or to raise the side camera ports for oversize cameras or spinning disks, or to use a microscope with an inactive bottom port on workbenches without openings.

Height compensation plate: 12 mm 11 522 031

Height compensation plate: 25 mm 11 522 036

Camera ports

The DMI 6000 B can be fitted with a variety of camera ports. Select the top port and/or bottom port with the selection of basic stands (see page 4). Select the side ports with the following modules:

Motorized side port, left only 11 888 255

You may select up to three different prisms from the following for this version:

- Side port prism, 100% left 11 888 259
- Side port prism, dichroic 630nm left 11 888 260
- Side port prism, 80% left 11 888 262
- Side port prism, 50% left 11 888 264

Motorized side port, right only 11 888 272

You may select up to three different prisms from the following for this version:

- Side port prism, 100% right 11 888 258
- Side port prism, 80% right 11 888 261
- Side port prism, 50% right 11 888 263

Motorized side port, right and left 11 888 273

You may select up to three different prisms from the following for this version:

- Side port prism, 100% right 11 888 258
- Side port prism, 100% left 11 888 259
- Side port prism, dichroic 630nm left 11 888 260
- Side port prism, 80% right 11 888 261
- Side port prism, 80% left 11 888 262
- Side port prism, 50% right 11 888 263
- Side port prism, 50% left 11 888 264

Observation and Documentation Tubes

The DMI 6000 B features a wide range of ergonomic tubes integrated in the stand. The interpupillary distance can be adjusted according to the Siedentopf principle. The complex tube lens system is based on an infinite beam path. It converges the parallel beam path coming from the lens and forms the object in the intermediate image plane. Also, the tube lens system, together with the eyepieces, corrects the remaining image errors not corrected by the objective.

Binocular Ergonomic Tube

Binocular observation tube

Siedentopf design

Field number to 25 mm

Eyepiece diameter 30 mm

Interpupillary distance range 55 mm to 75 mm

Variable viewing angle 10° to 45° 11 888 277

Binocular Ergonomic Tube with Bertrand lens

Binocular observation tube with Bertrand lens (for observation of back focal plane)

Siedentopf design

Field number to 25 mm

Eyepiece diameter 30 mm

Interpupillary distance range 55 mm to 75 mm

Variable viewing angle 10° to 45° 11 888 276

Trinocular Ergonomic Tube

Binocular observation tube with side camera port and variable light path, 100% visual/0% camera, and 50% visual/50% camera

Siedentopf design

Field number to 25 mm

Eyepiece diameter 30 mm

Interpupillary distance range 55 mm to 75 mm

Variable viewing angle 10° to 45° 11 888 275

Trinocular Ergonomic Tube with Bertrand lens

Binocular observation tube with side camera port and variable light path, 100% visual/0% camera, and 50% visual/50% camera and Bertrand lens (for observation of back focal plane)

Siedentopf design

Field number to 25 mm

Eyepiece diameter 30 mm

Interpupillary distance range 55 mm to 75 mm

Variable viewing angle 10° to 45° 11 888 253



Fig. 21: Binocular Ergotube



Fig. 22: Siedentopf tube with interpupillary distance adjustment

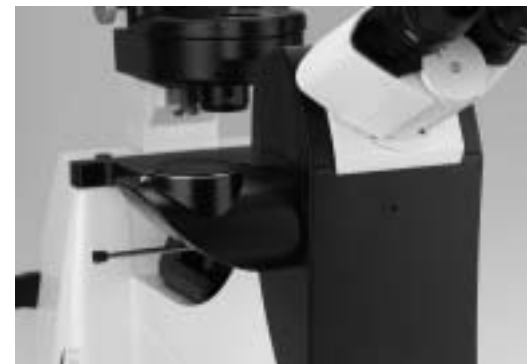

Fig. 23: Trinocular Ergotube



Fig. 24: Trinocular Ergotube with Bertrand lens

Eyepieces, eyepiece adapter tubes, graticules for tube eyepiece

A wide range of eyepieces with 10x, 12.5x, 16x or 25x magnification (for field numbers of up to 25 mm) are available for the tubes. Special eyepieces for eyeglass wearers are available, as are eyepieces with adjustable eyelenses (M eyepieces) that are designed to accommodate a variety of graticules. The standard eyepiece is the 10x model; for microphotography applications 12.5x eyepiece magnification is frequently preferred for greater focusing accuracy. This results in a smaller object field, however. The eyepiece magnifications 16x and 25x are only useful for special situations. They may frequently exceed the "useful magnification" ($V < 1000 \times$ objective aperture), thus resulting in a lack of sharpness. All eyepieces have removable or fold-down eyecups and can be used with or without eyeglasses. Eyepieces identified with M are equipped with a focusing eyelens for dioptric equalization (from -6.8 to $+4.2$ or -6 to $+5$) and graticule holder.

The outer diameter of the eyepiece is $D = 30\text{mm}$. Graticule diameter is $D = 26\text{mm}$. The eyepiece data are engraved, e.g. HC PLAN 10x/20 oo M. HC PLAN= correction type, 10x = magnification/20 = field number FOV, oo = glasses type (high exit pupil), M = dioptric adjustment/graticule holder

Oculars with FOV 20

- Eyepiece HC PLAN 10x/20 BR. 11 507 801
- Eyepiece HC PLAN 10x/20 BR.M 11 507 802

Eyepiece with FOV 22

Eyepiece HC PLAN S 10x/22 Br.M 11 507 807

Eyepiece with FOV 25

Eyepiece HC PLAN S 10x/25 Br.M 11 507 808

Special Eyepieces with High Magnification

- Eyepiece HC PLAN 12.5x/16 BR. M 11 506 515
- Eyepiece 16x/14B, adjustable 10 445 301
- Eyepiece 25x/9.5B, adjustable 10 445 302
- Distance ring for eyepieces 16x/14 B and eyepiece 25x/9.5B 11 506 808

Photo Oculars, Eyepiece Tubes, Format Graticules

For adapting microphotographic equipment, an exactly matched combination of photo eyepiece, eyepiece tube, and focusing and framing graticule is required. The focusing and framing graticule is inserted into the observation eyepiece HC PLAN M and displays the current photograph format. In addition, the graticule has focusing marks for precise focusing.



Fig. 25: Eyepieces

For Photo Eyepiece 10x

- Eyepiece tube HC DR 27/10x for MPS 11 541 514
- Eyepiece HC 10x/16 Photo 11 541 501
- Focusing and framing graticule F6, D = 26 mm 11 506 961

For Photo Eyepiece 8x

- Eyepiece tube HC DR 27/8x for MPS 11 541 513
- Eyepiece HC 8x/20 Photo 11 541 500
- Focusing and framing graticule F5, 26 mm 11 506 960

For Photo Eyepiece 12.5x

- Eyepiece tube HC DR 27/12.5x for MPS 11 541 515
- Eyepiece HC 12.5x/13 Photo 11 541 535
- Focusing and framing graticule F8, 26 mm 11 506 963



Fig. 26: Photo oculars

Focusing and Framing Graticules for Length Measurements, Comparison, and Counting Methods

For HC PLAN eyepieces

- Graticule 10mm = 100 parts, D = 26 mm 11 506 950
- Graticule 10mm = 200 parts, D = 26 mm 11 506 951
- Crosshair graticule, D = 26 mm 11 506 953
- Crosshair graticule with graduation
10mm = 100 parts, D = 26 mm 11 506 952
- Graticule with grid 10 x 10 mm,
0.1 mm graduation, D = 26 mm 11 506 954
- Graticule with grid 10 x 10 mm,
1 mm graduation, D = 26 mm 11 506 955
- Graticule, Snyder-Graff method,
D = 26 mm (only for 10x eyepiece) 11 566 950
- Graticule, ASTM E 112, D = 26 mm
(only for 10x eyepiece) 11 566 951

Stage Micrometer

- Transmitted light 2 mm = 200T, glass carrier with scale
1 scale interval = 10 μ m 11 513 106
- Incident light 10mm = 100T
for overview objectives (e.g. 1.25x) 11 519 963

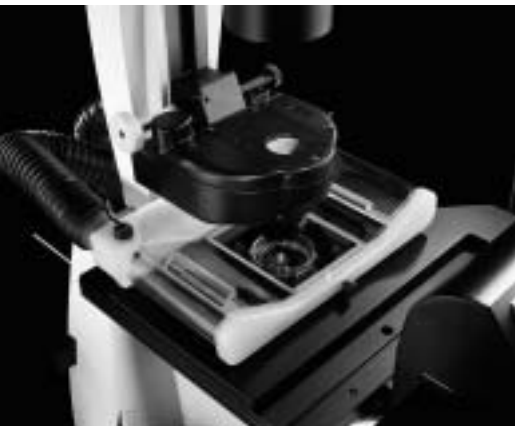

Fig. 27: Stage with incubator

Stages and Specimen Holders

A wide range of specimen stages is available. The most important are the following:

- Fixed stage (248 mm x 204 mm) normal (with and without integrated thermal insulation), heatable and temperature-controlled
- Fixed micromanipulation stage (248 mm x 112 mm) normal (with and without integrated thermal insulation), heatable, and temperature-controlled
- Regular manual 3-plate cross-stage, positioning range 83 mm x 127 mm (with and without integrated thermal insulation)
- Manual micromanipulation 3-plate cross-stage, positioning range 40 mm x 40 mm (with and without integrated thermal insulation)
- Motorized micromanipulation 3-plate cross-stage, positioning range 40 mm x 40 mm
- Manual rotating stage
- Scanning stage IM 120 x 100 (motors on top)
- Scanning stage IM 120 x 100 (motors on bottom)

The 20 mm high stages are solidly attached to the microscope by three screws. In the case of fixed stages, an attachable mechanical stage may be installed at the left or right (see below).

A controller is required for the heated stages. Temperature range: 3 °C above room temperature to 60 °C (± 0.1 °C). See the section on control units or Leica Microsystem's separate brochure, "Live on Stage". There you will also find further information on the differences between analog and digital control units.

A thermostat is required for the temperature-controlled stages. Temperature range: 0 °C above room temperature to 65 °C (-0.1 °C) depending on the coolant and thermostat used. See the section on control units or Leica Microsystem's separate brochure, "Live on Stage".

Fixed Stage (248 mm x 204 mm)

Regular fixed stage

Aluminum, ceramic-coated, extremely scratch-proof, precisely plane-parallel, including two round 80mm inserts with 20 mm and 40 mm openings.

Drillings on the right and left to accommodate attachable mechanical stages;

three-point mounting.

Without integrated ceramic insulation on the underside of the stage

11 522 011

With integrated ceramic insulation on the underside of the stage

11 522 033

Fixed Heating Stage (248 mm x 212 mm)

Regular fixed heating stage

Temperature range: 3 °C above room temperature to 60 °C (± 0.1 °C).

One-piece stage machined from bar stock with an oval 20 x 30 mm opening. Even distribution of warmth due to lack of separate inserts.

Usable for all electrophysiological applications due to lack of interference with electronics.

Aluminum, black anodized, precisely plane-parallel.

Drillings on the right and left to accommodate attachable mechanical stages;

three-point mounting

11 522 012

Fixed Temperature-controlled Stage (248 mm x 212 mm)

Regular fixed temperature-controlled stage

Temperature range: 0 °C above room temperature to 65 °C (± 0.1 °C) depending on the coolant and thermostat used

One-piece stage machined from bar stock with an oval 20 mm x 30 mm opening. Even distribution of temperature due to lack of separate inserts.

Usable for all electrophysiological applications due to lack of interference with electronics. Circulating liquid for cooling effect.

Aluminum, black anodized, precisely plane-parallel.

Drillings on the right and left to accommodate attachable mechanical stages;

three-point mounting

11 522 013

Stage Clamps for Regular Fixed Stage (for 11 522 011 and 11 522 033)

Glass slides (76 mm x 26 mm) can be held in place with stage clamps

11 512 650

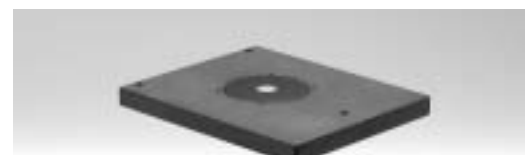

Fig. 28: Fixed stage



Fig. 29: Fixed heating stage



Fig. 30: Fixed cooling stage

Attachable Mechanical Stages for Regular Fixed Stages

(for 11 522 011, 11 522 012 and 11 522 913)

Attachable mechanical stages for all regular fixed stages measuring 248 mm x >200 mm to accommodate a variety of application inserts.

Suitable for mounting on the left or right of the fixed stage.

Positioning range: 83 mm x 127 mm

Ergonomic operating arm: Low position, does not interfere with microscope controls or camera ports, with coaxial drive for x and y. Adjustable torque, extremely precise and sensitive.

Ceramic bearing surfaces in x and y.

z positioning precision adjustable over the positioning range.

Precise snap-in mechanism for a variety of inserts.

Integrated scaling in x and y (optional for a number of inserts)

11 522 014

Inserts for Attachable Mechanical Stage 11 522 014

The retaining frames are inserted into the attachable mechanical stage via a precise snap-in mechanism. Material: Aluminum, black anodized.

- Retaining frame for tissue cultures (384 chambers) (133.5 mm x 88.5 mm) 11 520 583
- Retaining frame for tissue cultures (24 chambers) (133.5 mm x 88.5 mm) 11 520 584
- Retaining frame for Terasaki plates, 60 or 72 wells 11 520 585
- Retaining frame for bottles with a basic area 125 mm x 77 mm 11 520 586
- Retaining frame for bottles with a basic area 82 mm x 77 mm 11 520 587
- Retaining frame for microtiter plates 96 or 120 wells 11 520 589
- Retaining frame for Petri dish dia. 88 mm / height 16 mm 11 520 590
- Retaining frame for Petri dish dia. 54 mm / height 15 mm 11 520 591
- Retaining frame for Petri dish dia. 36 mm / height 10 mm 11 520 592
- Retaining frame for glass slide 76 mm x 26 mm 11 520 593
- Retaining frame for Bellco test tubes dia. max. 12 mm 11 520 594
- Retaining frame for plankton chamber with a basic area (102.5 mm x 28–50.5 mm) 115 205 95
- Holder with central drilling 11 520 596
- Universal retaining frame M for Petri dishes 24–68 mm or glass slides 11 520 688
- Universal retaining frame MX for Petri dishes 87–92 mm or multiwells 11 520 689
- Universal retaining frame M-Duo for 2 Petri dishes max. 56 mm or 1 Petri dish max. 40 plus 1 glass slide 11 531 798
- Heatable universal retaining frame MH for Petri dishes 24–68 mm or glass slides (round 35mm and oval 10 mm x 30 mm opening) 11 531 799
- Heatable universal retaining frame MH for Petri dishes 24–68 mm or glass slides (rectangular opening 47 mm x 21 mm) 11 531 817



Fig. 31: Universal retaining frame M



Fig. 32: Various inserts for attachable mechanical stage

Fixed Micromanipulation Stage (248 mm x 112 mm)

Narrow, fixed stage for micromanipulation
Aluminum, ceramic-coated, extremely scratchproof, precisely plane-parallel, including two round 80 mm inserts with 20 mm and 40 mm openings.

Drillings on the right and left to accommodate attachable mechanical stages;

three-point mounting.

Without integrated ceramic insulation on the underside of the stage 11 522 015

With integrated ceramic insulation on the underside of the stage 11 522 032

Fixed Micromanipulation Heating Stage (248 mm x 112 mm)

Regular fixed heating stage
Temperature range: 3 °C above room temperature to 60 °C (± 0.1 °C).

One-piece stage machined from bar stock with an oval 20 mm x 30 mm opening. Even distribution of warmth due to lack of separate inserts.

Usable for all electrophysiological applications due to lack of interference with electronics.

Aluminum, black anodized, precisely plane-parallel.

Drillings on the right and left to accommodate attachable mechanical stages;

three-point mounting 11 522 016

Fixed Temperature-controlled Micromanipulation Stage (248 mm x 112 mm)

Regular fixed temperature-controlled stage
Temperature range: 0 °C above room temperature to 65 °C (± 0.1 °C) depending on the coolant and thermostat used.

One-piece stage machined from bar stock with an oval 20 mm x 30 mm opening. Even distribution of temperature due to lack of separate inserts.

Usable for all electrophysiological applications due to lack of interference with electronics. Circulating liquid for cooling effect.

Aluminum, black anodized, precisely plane-parallel.

Drillings on the right and left to accommodate attachable mechanical stages;

three-point mounting 11 522 017

Stage Clamps for Regular Fixed Stage (for 11 522 015 and 11 522 032)

Glass slides (76 mm x 26 mm) can be held in place with stage clamps 11 512 650

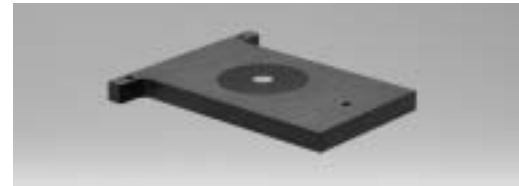

Fig. 33: Fixed micromanipulation stage

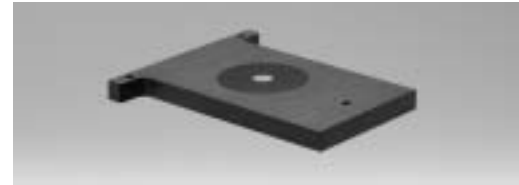

Fig. 34: Heating micromanipulation stage

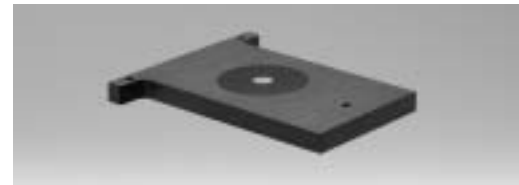

Fig. 35: Cooling micromanipulation stage



Fig. 36: Attachable mechanical stage for micromanipulation



Fig. 37: Attachable mechanical stage for micromanipulation;
a) insert for glass slides
b) insert for 30mm Petri dishes
c) insert for 50mm Petri dishes



Fig. 38: Glass stage plate

Attachable Mechanical Stages for Fixed Micromanipulation Stages (for 11 522 015 to 11 522 017)

Attachable mechanical stages for all fixed micromanipulation stages measuring 248 mm x >112 mm to accommodate a variety of application inserts.

Suitable for mounting on the left or right of the fixed stage.

Positioning range: 35 mm x 35 mm.

Ergonomic operating arm, angled forward: low position, does not interfere with microscope controls or camera ports, with coaxial drive for x and y. Adjustable torque, extremely precise and sensitive.

Ceramic bearing surfaces in x and y. 11 522 018

Inserts for Attachable Mechanical Stage 11 522 018

The retaining frames are positioned and held by 2 locking screws. Material: Aluminum, black anodized.

- Retaining frame for Petri dish dia. 30 mm 11 522 042
- Retaining frame for Petri dish dia. 50 mm 11 522 043
- Retaining frame for glass slide 76 mm x 26 mm 11 522 044

Regular Manual 3-plate Cross-stage

Regular 3-plate stage without insert

Positioning range: 83 mm x 127 mm

Aluminum, extremely scratch-resistant, precisely plane-parallel for 160 mm x 110 mm inserts.

Integrated receptacle for Petri dishes.

Ergonomic operating arm: low position, does not interfere with microscope controls or camera ports, with coaxial drive for x and y. Adjustable torque, extremely precise and sensitive.

Three-point mounting.

Without integrated ceramic insulation on the underside of the stage 11 522 019

With integrated ceramic insulation on the underside of the stage 11 522 034

Inserts for Regular Manual 3-plate Cross-stage 11 521 019 and Scanning Stages 11 522 022 and 11 522 023

The retaining frames are inserted into the attachable mechanical stage via a tension ring mechanism. Material: Aluminum, black anodized.

- Insert for glass slide 76 mm x 26 mm 11 531 433
- Glass stage plate with 15 mm round opening 11 522 045
- Insert for microtiter plates
96 or 120 wells (tray size: 127 mm x 85 mm) 11 531 434
- Insert for Terasaki plates
60 or 72 wells (tray size: 56 mm x 82 mm) 11 531 435
- Insert for Hamax 60 (tray size: 93 mm x 66 mm) 11 531 436
- Insert frame for Petri dish dia. 36 mm 11 531 437
- Insert frame for Petri dish dia. 54 mm 11 531 438
- Insert frame for Petri dish dia. 65 mm 11 531 439
- Insert frame for Petri dish dia. 88.5 mm 11 531 440
- Universal insert frame for Petri dishes 24–68 mm
or glass slides 11 531 441

- Universal insert frame LK for Petri dishes 24–68 mm or glass slides (with depressions at sides for micromanipulation) 11 531 818
- Universal insert frame LKX for Petri dishes 87–92 mm or multiwells 11 531 819
- Universal insert frame LK-DUO for 2 Petri dishes max. 56 mm or 1 Petri dish max. 40 plus 1 glass slide 11 531 820
- Heatable universal retaining frame LKH for Petri dishes 24–68 mm or glass slides (round 35 mm and oval 10 mm x 30 mm opening) 11 531 821
- Heatable universal insert frame LKHL for Petri dishes 24–68 mm or glass slides (rectangular opening 47 mm x 21 mm) 11 531 645
- Heating insert P with accessories. Opening dia. 32 mm, cover with glass stage plate (for DIC). Compatible with incubator S 11 531 172
- Temperature-controlled insert P with accessories. opening dia. 32 mm, cover with glass stage plate (for DIC). Compatible with incubator S 11 531 824
- Heating insert M06 for 06 multiwell plates by Falcon® No. 3072/3075 11 531 590
- Heating insert M12 for 12 multiwell plates by Falcon® No. 3047/3226 11 531 823
- Heating insert M24 for 24 multiwell plates by Falcon® No. 3043/3225 11 531 591
- Heating insert M96 for 06 multiwell plates by Falcon® No. 3046/3224 11 531 644

Slim 3-plate Cross-stage for Micromanipulation

Regular 3-plate stage with two round 80 mm inserts with 20 mm and 40 mm openings.

Positioning range: 40 mm x 40 mm

Aluminum, extremely scratch-resistant, precisely plane-parallel.

Integrated receptacle for Petri dishes.

Ergonomic operating arm: low position, does not interfere with microscope controls or camera ports, with coaxial drive for x and y. Adjustable torque, extremely precise and sensitive.

Three-point mounting.

- Manual
 - Without integrated ceramic insulation on the underside of the stage 11 522 020
 - With integrated ceramic insulation on the underside of the stage 11 522 035
- Motorized
 - Without integrated ceramic insulation on the underside of the stage 11 522 021
 - With integrated ceramic insulation on the underside of the stage coming soon



Fig. 39: 3-plate cross-stage



Fig. 40: Insert for 3-plate cross-stage



Fig. 41: Heating insert P



Fig. 42: Slim 3-plate cross-stage



Fig. 43: Scanning stage IM 120 x 100



Fig. 44: Control unit ScST



Fig. 45: Joystick for ScST



Fig. 46: SmartMove

Scanning Stage IM 120 x 100

3-plate Märzhäuser scanning stage without insert

Positioning range: 120 mm x 100 mm

Three-point mounting.

Aluminum, extremely scratch-resistant, precisely plane-parallel for 160 mm x 110 mm inserts.

Max. positioning speed: 10 mm/sec. to 100 mm/sec.*

Max. resolution: 0.02–0.04 μm^*

Reproducibility: <math> < 1 \mu\text{m}^*</math>

Precision: $\pm 3 \mu\text{m}^*$

*) Depending on spindle used: 1 mm, 2 mm or 4 mm

- With motors on top 11 522 022
- With motors on bottom 11 522 023

Accessories for Scanning Stages

- Inserts page 16/17
- Set of cables for Märzhäuser stages 11 505 106
- Cable adapter for x/y/z control 11 500 327
- Control unit for scanning stage 11 505 094
- SmartMove for DM/DMI series 11 505 180

Manual Rotating Stage

Rotating stage with x/y adjustment for Petri dishes to 50 mm with insert frame for glass slide.

Positioning range: 80 mm x 80 mm, 360°.

Three-point mounting.

Aluminum, extremely scratch-resistant 11 521 559



Fig. 47: Rotating stage

Transmitted Light Illumination

The transmitted light illumination unit consists of an illumination and condenser carrier. Its excellent light utilization is ensured by replaceable Leica lamp housings and optimized aspherical collectors. Optimal and homogeneous illumination is a precondition for all transmitted light contrast methods such as phase modulation or interference contrast.

Manual, Coded Transmitted Light Illumination Arm

Compact transmitted-light illumination arm

- With integrated tilting mechanism
- With integrated manual field diaphragm
- With integrated manual filter magazine for 2 replaceable filter positions
 - One position factory-equipped with a shutter
- With condenser quick-changer
- With automatic condenser identification
- With standard lamp housing changer for all Leica lamp housings
- with integrated duct for lamp housing cable 11 522 026

Motorized, Coded Transmitted Light Illumination Arm

Compact transmitted-light illumination arm

- With integrated tilting mechanism
- With integrated motorized field diaphragm
- With integrated motorized filter magazine for 2 replaceable filter positions
- With integrated motorized shutter
- With integrated CCIC (constant-color intensity control)
- With condenser quick-changer
- With automatic condenser identification
- With standard lamp housing changer for all Leica lamp housings
- With integrated duct for lamp housing cable 11 522 025

Light Filter Diameter 40mm, Unframed for Transmitted Light Illumination Arm

2 transmitted light filters can be swung in on the manual and motorized transmitted light illumination arms. A broad selection of filters is available to optimize illumination for observation and documentation.

- DLF, daylight filter 11 521 577
(blue, conversion filter e.g. for daylight film and/or visual observation)
- ALF, artificial light filter (red, correction filter for artificial light film) 11 521 578
- Panchromatic green filter 11 521 579
- Neutral filter N 16 (6.3%) 11 521 579
- Neutral filter N 4 (25%) 11 521 580
- Neutral filter N 2 (50%) 11 521 581
- VG 9, narrow band filter 11 521 583



Fig. 48: Transmitted-light illumination arm



Fig. 49: Stand with transmitted-light illumination arm



Fig. 50: Filter magazine in illumination arm

Condensers and Accessories

A variety of condensers are available for the Leica DMI 6000 B. All condensers feature a 7-position condenser disk to accommodate light rings, IC prisms or slit diaphragms. They can be individually equipped and are easy to use.

All condensers can be used for bright field, phase, polarization, and interference contrast.

All condensers feature:

- An aperture diaphragm
- A mount for interchangeable condenser heads
- A mount for a polarizer
- A filter mount with a diameter of 32 mm

S70/0.30 Condenser:

Features a free working distance of 70 mm and a numerical aperture of 0.30 and is particularly suitable for specimens in high-volume containers at magnifications of up to 40x. An auxiliary lens is swung in for magnifications of 1.25x to 5x (i.e. for larger objects) to provide homogeneous illumination all the way to the edge of the entire 25 mm field of view.

S28/0.55 condenser:

Features a free working distance of 28mm and a numerical aperture of 0.55 and is particularly suitable for thicker specimens (living cells) for highest resolution and magnifications of up to 100x. The specimens can be examined in all common dishes and trays up to 28 mm. For micromanipulation, 5 mm more working distance is available than with conventional S23 condensers. In addition to the standard contrast methods, this condenser is also suitable for **dark field contrast** at objective apertures of up to 0.40.

Suitable inserts are available for this condenser for **integrated modulation contrast** and **integrated positive and negative phase contrast**.

S28/0.53 condenser:

Features a free working distance of 23 mm and a numerical aperture of 0.53 and is particularly suitable for routine examinations of living cells, specimens for high resolutions and magnifications up to 100x. The specimens can be examined in all common dishes and trays up to 23 mm.

In addition to the standard contrast methods, this condenser is also suitable for **dark field contrast** at objective apertures of up to 0.40.

Suitable inserts are available for this condenser for **integrated modulation contrast** and **integrated positive and negative phase contrast**.



Fig. 51: S70 condenser



Fig. 52: S20 condenser



Fig. 53: S1 condenser

S1/0.90 and S1/1.40 Oil Condensers:

Feature a free working distance of 1mm and a numerical aperture of 0.90 (dry) or 1.40 (oil). They are especially suited for best resolutions and highest magnifications and resolutions in applications that do not require large working distances, such as the study of intracellular processes or time lapse observation. The specimens can be on glass slides or dishes. In addition to the standard contrast methods, these condensers are also suitable for **darkfield contrast** at objective apertures of up to 0.70.

For transmitted light methods, the Leica DMI 6000 B can accommodate the full range of objectives with magnifications from 1.25x to 100x. With the available condensers, specimens can be viewed in virtually any vessel.



Fig. 54: Condenser base for S1–S28

S70 Condensers

Manual

- Coded manual condenser including head S70/0.30 11 522 008
- Light ring set for phase contrast S70/0.30 11 521 506
- Manual auxiliary lens for low magnifications 11 522 024
- Manual polarizer holder including polarizer 11 522 010
- Wollaston prisms for DIC see page 29

Motorized

- Motorized condenser including head S70/0.30 coming soon
- Light ring set for phase contrast S70/0.30 11 521 506
- Motorized auxiliary lens for low magnifications coming soon
- Motorized polarizer holder including polarizer 11 522 009
- Wollaston prisms for DIC see page 29



Fig. 55: S28 condenser head

S28 Condensers

Manual with Fixed Condenser Head

- Coded manual condenser base with fixed mount for all condenser heads, S1–S28 11 522 006
- Condenser head S28/0.55 11 505 175
- Light ring set for PH and DF contrast S23–S28 11 521 505
- Light stops for modulation contrast coming soon
- Manual polarizer holder including polarizer 11 522 010
- Wollaston prisms for DIC see page 29

Manual with Manually Movable Condenser Head

- Coded manual condenser base with manually movable mount for all condenser heads, S1–S28 11 522 005
- Condenser head S28/0.55 11 505 175
- Light ring set for PH and DF contrast S23–S28 11 521 505
- Light stops for modulation contrast coming soon
- Manual polarizer holder including polarizer 11 522 010
- Wollaston prisms for DIC see page 29



Fig. 56: Condenser heads and spacer ring

Motorized with Fixed Condenser Head

- Motorized condenser base with fixed mount for all condenser heads, S1–S28 11 522 007
- Condenser head S28/0.55 11 505 175
- Light ring set for PH and DF contrast S23–S28 11 521 505
- Light stops for modulation contrast coming soon
- Motorized polarizer holder including polarizer 11 522 009
- Wollaston prisms for DIC see page 29

Motorized with Motorized Movable Condenser Head

- Motorized condenser base with motorized movable mount for all condenser heads, S1–S28 11 522 004
- Condenser head S28/0.55 11 505 175
- Light ring set for PH and DF contrast S23–S28 11 521 505
- Light stops for modulation contrast coming soon
- Motorized polarizer holder including polarizer 11 522 009
- Wollaston prisms for DIC see page 29

S23 Condensers

Manual with Fixed Condenser Head

- Coded manual condenser base with fixed mount for all condenser heads, S1–S28 11 522 006
- Condenser head S23/0.53 11 521 500
- Light ring set for PH and DF contrast S23–S28 11 521 505
- Light stops for modulation contrast coming soon
- Manual polarizer holder including polarizer 11 522 010
- Wollaston prisms for DIC see page 29

Manual with Manually Movable Condenser Head

- Coded manual condenser base with manually movable mount for all condenser heads, S1–S28 11 522 005
- Condenser head S23/0.53 11 521 500
- Light ring set for PH and DF contrast S23–S28 11 521 505
- Light stops for modulation contrast coming soon
- Manual polarizer holder including polarizer 11 522 010
- Wollaston prisms for DIC see page 29

Motorized with Fixed Condenser Head

- Motorized condenser base with fixed mount for all condenser heads, S1–S28 11 522 007
- Condenser head S23/0.53 11 521 500
- Light ring set for PH and DF contrast S23–S28 11 521 505
- Light stops for modulation contrast coming soon
- Motorized polarizer holder including polarizer 11 522 009
- Wollaston prisms for DIC see page 29

Motorized with Motorized Movable Condenser Head

- Motorized condenser base with motorized movable mount for all condenser heads, S1–S28 11 522 004
- Condenser head S23/0.53 11 521 500
- Light ring set for PH and DF contrast S23–S28 11 521 505
- Light stops for modulation contrast coming soon
- Motorized polarizer holder including polarizer 11 522 009
- Wollaston prisms for DIC see page 29

S1 Condensers (Dry)

Manual with Fixed Condenser Head

- Coded manual condenser base with fixed mount for all condenser heads, S1–S28 11 522 006
- Spacer ring for condenser head S1 11 521 502
- Condenser head S1/0.90 dry 11 505 150
- Light ring set for PH and DF contrast S1 11 521 504
- Manual polarizer holder including polarizer 11 522 010
- Wollaston prisms for DIC see page 29

Manual with Manually Movable Condenser Head

- Coded manual condenser base with manually movable mount for all condenser heads, S1–S28 11 522 005
- Spacer ring for condenser head S1 11 521 502
- Condenser head S1/0.90 dry 11 505 150
- Light ring set for PH and DF contrast S1 11 521 504
- Manual polarizer holder including polarizer 11 522 010
- Wollaston prisms for DIC see page 29

Motorized with Fixed Condenser Head

- Motorized condenser base with fixed mount for all condenser heads, S1–S28 11 522 007
- Spacer ring for condenser head S1 11 521 502
- Condenser head S1/0.90 dry 11 505 150
- Light ring set for PH and DF contrast S1 11 521 504
- Motorized polarizer holder including polarizer 11 522 009
- Wollaston prisms for DIC see page 29

Motorized with Motorized Movable Condenser Head

- Motorized condenser base with motorized movable mount for all condenser heads, S1–S28 11 522 004
- Spacer ring for condenser head S1 11 521 502
- Condenser head S1/0.90 dry 11 505 150
- Light ring set for PH and DF contrast S1 11 521 504
- Motorized polarizer holder including polarizer 11 522 009
- Wollaston prisms for DIC see page 29



Fig. 57: Condenser head S1 and spacer ring



Fig. 58: Spacer ring



Fig. 59: Light rings

S1 Condensers (Oil)

Manual with Fixed Condenser Head

- Coded manual condenser base with fixed mount for all condenser heads, S1–S28 11 522 006
- Spacer ring for condenser head S1 11 521 502
- Condenser head S1/1.40 oil 11 551 004
- Light ring set for PH and DF contrast S1 11 521 504
- Manual polarizer holder including polarizer 11 522 010
- Wollaston prisms for DIC see page 29

Manual with Manually Movable Condenser Head

- Coded manual condenser base with manually movable mount for all condenser heads, S1–S28 11 522 005
- Spacer ring for condenser head S1 11 521 502
- Condenser head S1/1.40 oil 11 551 004
- Light ring set for PH and DF contrast S1 11 521 504
- Manual polarizer holder including polarizer 11 522 010
- Wollaston prisms for DIC see page 29

Motorized with Fixed Condenser Head

- Motorized condenser base with fixed mount for all condenser heads, S1–S28 11 522 007
- Spacer ring for condenser head S1 11 521 502
- Condenser head S1/1.40 oil 11 551 004
- Light ring set for PH and DF contrast S1 11 521 504
- Motorized polarizer holder including polarizer 11 522 009
- Wollaston prisms for DIC see page 29

Motorized with Motorized Movable Condenser Head

- Motorized condenser base with motorized movable mount for all condenser heads, S1–S28 11 522 004
- Spacer ring for condenser head S1 11 521 502
- Condenser head S1/1.40 oil 11 551 004
- Light ring set for PH and DF contrast S1 11 521 504
- Motorized polarizer holder including polarizer 11 522 009
- Wollaston prisms for DIC see page 29

Focusing Telescope (Bertrand Lens)

A focusing telescope is required when adjusting phase contrast, modulation contrast or differential interference contrast in order to view the rear focal plane of the objective. The following tubes are already equipped with a telescope:

- Binocular ergonomic tube with Bertrand lens 11 888 276
- Trinocular ergonomic tube with Bertrand lens 11 888 253

Focusing telescope diameter 30 mm 11 505 070



Fig. 60: Focusing telescope

Integrated Modulation Contrast and Integrated Positive and Negative Phase Contrast

(coming soon)

Integrated modulation contrast, as well as integrated positive and negative phase contrast are available with the following stand variants:

- DMI 6000 B basic stand with bottom port
(ready for IMC* and top port) 11 888 284
 - DMI 6000 B basic stand without bottom port
(ready for IMC* and top port) 11 888 285
 - DMI 6000 B basic stand with bottom port
(ready for IMC* without top port) 11 888 288
 - DMI 6000 B basic stand without bottom port
(ready for IMC* without top port) 11 888 289
- and the S23 and S28 condensers (see above).

Either an IMC/PhaCo mount or a front module which is factory-installed in the 11 888 284, 11 888 285, 11 888 288 and 11 888 289 stands is required for this purpose. The IMC/PhaCo mount is an opening in the stand for the modulation contrast or phase contrast slider. The front modules are identical, but feature an additional magnification changer.

- Mount for integrated modulation
and phase contrast 11 888 281
- Front module for integrated modulation and
phase contrast and magnification changer 1.5x 11 888 283
- Front module for integrated modulation and
phase contrast and magnification changer 1.6x 11 888 280
- Front module for integrated modulation and
phase contrast and magnification changer 2.0x 11 888 282

The magnification changers (11 888 283, 11 888 280 and 11 888 282) affect the top camera port and are not available in combination with the motorized magnification changer (see page 34).

Phase contrast slider

11 522 002

Different phase rings must be placed in the contrast slider for the different eyepoints of the objectives. For the eyepoints of the objectives, please refer to the objective list (see page 42).

A variety of phase rings are available for clear to milky solutions [w] or for reddish solutions [r]. In addition, a distinction is made between positive [+] and negative [-] phase contrast.

- Phase contrast ring PH1 (A/w/+) coming soon
- Phase contrast ring PH1 (C/w/+) coming soon
- Phase contrast ring PH1 (A/w/-) coming soon
- Phase contrast ring PH1 (C/w/-) coming soon
- Phase contrast ring PH1 (A/r/+) coming soon
- Phase contrast ring PH1 (C/r/+) coming soon

Further phase contrast rings are currently being planned.

For more information, please contact the hotline:

MQM-Hotline@leica-microsystems.com

Integrated modulation contrast slider

11 522 003

Different modulators must be placed in the modulation contrast slider for the different eyepoints of the objectives. For the eyepoints of the objectives, please refer to the objective list (see page 42). The contrast (soft or hard) and the resolution can be adjusted to suit your personal requirements with the knurled screws.

- Modulator A (10–20) coming soon
- Modulator C (32–63) coming soon

Further modulators are currently being planned. For more information, please contact the hotline:

MQM-Hotline@leica-microsystems.com

Transmitted Light Polarization Contrast

For transmitted light polarization contrast, a revolving polarizer and an analyzer (in the case of the Leica DMI 6000 B, a fixed one) is required. In addition to this basic equipment, Leica Microsystems recommend the use of fixed compensators such as lambda or lambda/4 plates for better contrasting of specimens with small path differences. The lambda plates are inserted between the polarizer and analyzer; in the case of the Leica DMI 6000 B, they are on the polarizer. The compensator is activated by turning the polarizer 180°. The lambda plate generates polarization color effects.

Low-strain objectives (marked with a P in the objective list) enhance the quality of the polarization contrast.

For Motorized Condensers

- Motorized polarizer holder including polarizer without lambda plate coming soon
- Motorized polarizer holder including polarizer with lambda plate 11 522 009

For Manual Condensers

- Manual triple polarizer holder 11 521 515
- Manual single polarizer holder 11 522 010
- Polarizer with lambda plate 11 521 700

The analyzer is located below the objective turret. To insert the analyzer, remove the cover for the unused objective DIC disk opening.

Component of stand 11 -020-437-101-013

Analyzer ICT/P

- In slide bar 30mm x 5mm, fixed orientation 90° 11 555 045
- Analyzer ICT/P, 180°
in 30 mm x 5 mm slider, rotatable from 0°–180°
with drum head graduation, 1 graduation mark = 5° 11 555 066

Alternatively for stands with motorized incident-light fluorescence axis:

Analyzer Block 11 513 900

This analyzer is built into an empty fluorescence filter block and can be swung into the beam path using a motorized fluorescence disk. The swing direction is fixed at 0° (east-west).



Fig. 66: Polarizer and analyzer



Fig. 67: Analyzer block



Fig. 68: Analyzer on slider

Transmitted Light Differential Interference Contrast

For transmitted light interference contrast, a revolving polarizer, an analyzer (in the case of the Leica DMI 6000 B, a fixed one), and a set of Wollaston prisms is required. The Leica DMI 6000 B features both manual and additional motorized polarizer, analyzer, objective and condenser prism functions.

Leica DIC shows its strengths in IVF or ICSI, i. e. micromanipulation or microinjection. The illumination-side IC prisms are inserted in the condenser disk and objective-side IC prisms in the objective prism disk. The Leica DMI 6000 B realizes DIC at working distances of up to 70 mm (S70 condenser). Objectives with magnifications from 5x to 100x can be used for DIC. Fast (automatic) switching between DIC, brightfield and phase contrast is possible at all times without the need for DIC prisms to remain in the beam path. For valid combinations of prisms, condensers and objectives, please refer to the objective list on page 42.

The encoded objective turret recognizes the objective. The encoded motorized condenser automatically sets the correct condenser prism and places the polarizer in the beam path. The motorized objective prism disk selects the correct objective prism and sets the bias. The analyzer is automatically positioned in the beam path by the fluorescence disk. In addition, the luminous intensity, aperture diaphragm – and in the case of a motorized transmitted light illumination arm, the field diaphragm – are automatically set to the required values. The condenser head automatically swings in and out as necessary. The user can adjust and overwrite the preset values at any time.

For manual condensers, the manual objective prism disk, and in case of variants without fluorescence support (no fluorescence disk), the relevant components must be positioned and adjusted manually as required. Information about the required prisms is provided on the display.

Manual coded DIC objective system prism disk	11 522 029
Motorized coded DIC objective system prism disk	11 522 001

For Motorized Condensers

- Motorized polarizer holder including polarizer with lambda plate 11 522 009
- Motorized polarizer holder including polarizer without lambda plate coming soon



Fig. 69: DIC disk under objective turret



Fig. 70: Motorized DIC objective prism disk

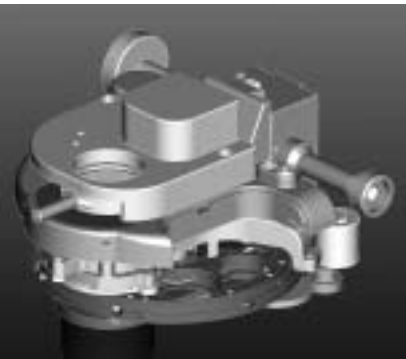

Fig. 71: Condenser with motorized polarizer

For Manual Condensers

- Manual polarizer holder including polarizer with lambda plate 11 522 010
- Manual polarizer holder including polarizer without lambda plate coming soon

The analyzer is located below the objective turret. The cover for the objective DIC disk opening is a component of the stand.

Analyzer ICT/P

In slide bar 30 mm x 5 mm, fixed orientation 90° 11 555 045

Analyzer ICT/P, 180°

In slide bar 30 mm x 5 mm, revolving from 0° to 180° with drum head graduation, 1 graduation mark = 5° 11 555 066

Alternatively for stands with motorized incident light fluorescence axis

Analyzer Block 11 513 900

This analyzer is built into an empty fluorescence filter block and can be swung into the beam path using a motorized fluorescence disk. The swing direction is fixed at 0° (east-west)

Wollaston prisms

Objective Prisms

- IC objective prism A 11 555 006
- IC objective prism C 11 555 009
- IC objective prism C1 11 555 038
- IC objective prism C2 11 555 039
- IC objective prism D 11 555 010
- IC objective prism D1 11 555 056
- IC objective prism E 11 555 046

Condenser Prisms

- IC condenser prism K3 11 555 017
- IC condenser prism K4 11 555 018
- IC condenser prism K5 11 555 019
- IC condenser prism K6 11 521 521
- IC condenser prism K7 11 521 522
- IC condenser prism K8 11 521 523
- IC condenser prism K9 11 555 030
- IC condenser prism K10 11 521 524
- IC condenser prism K11 11 521 529
- IC condenser prism K12, oil 11 521 540
- IC condenser prism K16 11 522 037



Fig. 72: DIC condenser prisms



Fig. 73: Objective prism D



Fig. 74: Analyzer block



Fig. 75: Analyzer on slider



Fig. 76: Filter with handle

Transmitted Light – Light Filters, Lambda and Lambda/4 Plate

D = 32 mm in holder with handle. For insertion in

- Triple filterholder 11 512 515

Mount above the manual condenser.

- DLF, daylight filter (blue, conversion filter for daylight film and visual observation) 11 514 753
- ALF, artificial light filter (red, correction filter for artificial light film) 11 514 754
- Panchromatic green filter for black/white photography 11 512 077
- VG 9, green filter for contrast enhancement (B/W) 11 563 122
- IL 546 nm (Polarization microscopy, interferometry) 11 563 155
- Neutral filter N2 (50%), in holder 11 543 092
- Neutral filter N4 (25%) 11 543 093
- Neutral filter N16 (6.3%) 11 543 184
- Neutral filter N16 (6.3% oblique) 11 514 752
- Polarizer 11 505 087
- Lambda plate (λ) 11 513 908
- Quarter lambda plate ($\lambda/4$) 11 513 570
- Polarizer with protective filter 11 513 711

Transmitted Light Filter d = 32mm

Without holder, to be placed loosely on the condenser.

- **DLF, daylight filter**
Blue conversion filter for daylight film and visual observation 11 504 046
- **ALF, artificial light filter**
Red, color correction filter for artificial light film 11 504 047
- **Panchromatic green filter**
For B/W photography and sensitivity enhancement of the eye 11 504 011
- **Green filter VG 9**
For B/W photography and sensitivity enhancement of the eye 11 504 004
- **Neutral gray filter N16**
6.3% transmission 11 504 005
- **Neutral gray filter N4**
25% transmission 11 504 006
- **Neutral gray filter N2**
50% transmission 11 504 007
- **Neutral gray filter N1.4**
70% transmission 11 504 008
- **Diffusion filter N** 11 504 012
- **Interference green filter VSS 546**
for monochromatic light 11 504 010
- **Blue glass filter BG 20**
Color contrast filter for Polaroid color photos and general contrast enhancement 11 504 009



Fig. 77: Transmitted-light filter

Incident Illumination for Bio-fluorescent Systems

The incident light fluorescence of the Leica DMI 6000 B features a completely new incident illumination system. The newly developed 1" illumination axis is designed for a variety of light sources. Optimal light flux with the greatest intensity and homogeneity is guaranteed. Light traps and the suppression of natural fluorescence result in an optimal black background. A variety of lamp mounts and mirror housings (up to 3 ports) also permit simultaneous use of multiple light sources.

The regular incident fluorescence illumination is based on high-intensity high-pressure 100 W mercury burners (Hg 100 W) with emission in the short-wave spectral range. Furthermore, xenon lamps (XE 75 W) are used when a broadband spectrum range is to be covered.

The excitation of the specimen is controlled by the FIM (Fluorescence Intensity Manager) method of decreasing light intensity in 5 increments for equalization of brightness levels for specimens with multiple dyes.

A centerable field diaphragm and 12 different aperture diaphragms that can be selected freely using the Fluorescence Intensity Manager ensure optimal Koehler illumination. The result is the best possible resolution, contrast and depth of field.

The incident light axis is equipped with an automatic light stop, which is activated at the touch of a button or via software to prevent specimens fading.

Depending on the application, a switchable auxiliary lens (booster) provides either maximum fluorescence intensity (factor: 1.4x in 75% center of field) or optimal homogeneity and brightness distribution (factor: 0.7x for the entire field).

The ultrafast filter changer supports switching between up to three different excitation wavelengths within 50 ms. This permits extremely fast switching between different emissions without moving filter blocks when using a dual or triple filter block (see below).



Fig. 78: Fluorescence drawer

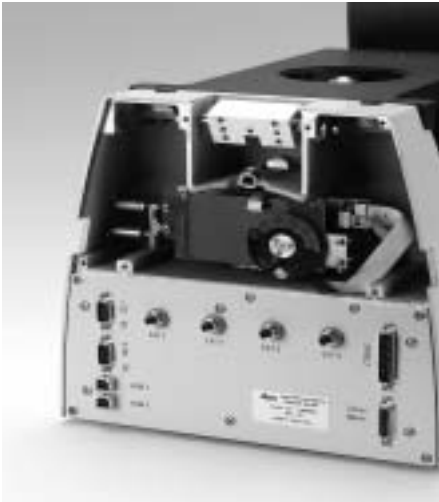

Fig. 79: Fluorescence module (installed)



Fig. 80: FIM and internal filter wheel

The Excitation Manager is available together with the ultrafast filter changer. It supports the tuning of emissions over 15 stages, two excitation wavelengths and a variety of intensities and the mixing of various colors.

Up to 6 fluorescence filter blocks on the disk contain an optimal combination of excitation, reflection, splitter, bandpass and blocking filters. The disk is integrated in the stand and is fully motorized and coded. Filter blocks can be switched in less than 0.2 sec.

A locking button releases the disk in a drawer for easy, convenient filter replacement within seconds, without tools.

The filter systems (blocks) have spring clamps for clicking into the incident light nosepiece. All blocks are designed to ensure zero pixel shift and completely suppress stray light to provide a completely black background for the fluorescent image.

All relevant blocks are equipped with a red absorption filter BG38 for contrast enhancement.

Incident and transmitted light can be used simultaneously for the optimal identification of fluorescent and non-fluorescent structures.

An adjusting window on the side permits the optimum setup of the lamp using the included adjusting aid.



Fig. 81: Fluorescence block A4



Fig. 82: Opening the drawer



Fig. 83: Fluorescence module

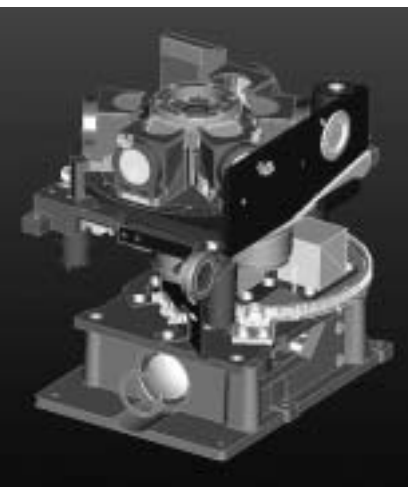

Fig. 84: 6-position fluorescence disk and motorized magnification changer

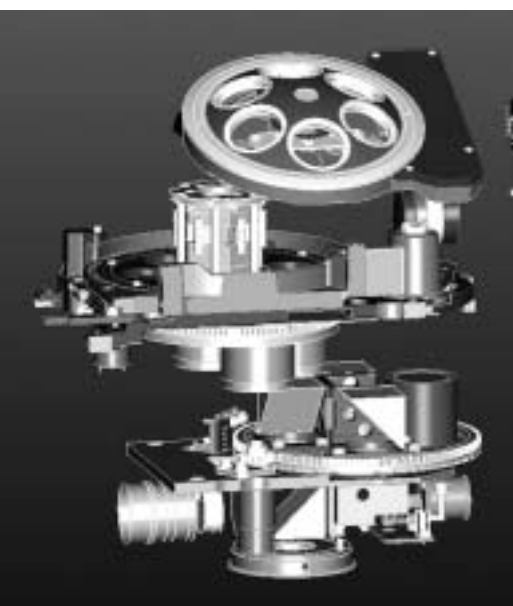

Fig. 85: 6-position fluorescence disk and motorized magnification changer

Motorized Fluorescence System and Motorized Magnification Changer

The optional motorized magnification changer is located on the fluorescence disk. In addition to the 1x tube lens, two further magnification levels can be introduced on an additional disk with 3 positions. The motorized magnification changer affects all camera ports. The magnification changer on the front module cannot be used at the same time.

Motorized 6-position Fluorescence Disk

- With Fluorescence Intensity Manager (FIM)
- With internal fast filter wheel (IFW) and Excitation Manager
- With motorized magnification changer including 1x tube lens at position 1 11 888 300

Motorized 6-position Fluorescence Disk

- With Fluorescence Intensity Manager (FIM)
- With motorized magnification changer including 1x tube lens at position 1 11 888 266

Motorized 6-position Fluorescence Disk

- With Fluorescence Intensity Manager (FIM)
- With internal fast filter wheel (IFW) and Excitation Manager including fixed 1x tube lens 11 888 301

Motorized 6-position fluorescence disk

- With Fluorescence Intensity Manager (FIM) including fixed 1x tube lens 11 888 267

Variants Without Incident Light Fluorescence:

Motorized Magnification Changer

- Including 1x tube lens at position 1 11 888 269

Fixed 1x tube lens

11 888 268

Magnification levels for motorized magnification changer

In addition to the 1x tube lens, one or two lenses can be installed on the disk.

- **1.5x tube lens** for motorized magnification changer 11 888 689
- **1.6x tube lens** for motorized magnification changer 11 888 265
- **2.0x tube lens** for motorized magnification changer 11 888 690

Lamp Mount for Lamp Housings (and Fibre Optic or Laser Couplings)

Lamp Mount

for one lamp housing or one fiber optic or laser coupling

Ergonomically angled 90° to the right

for optimal adjustment of L lamp housings 11 504 110

Lamp Mount

for one lamp housing, or a fiber optic or laser coupling

Under 0° for straight coupling and when using

incubator ML 11 504 111

Manual Mirror Housing

to accommodate two light sources, or fiber optic or laser couplings

Ergonomically angled 90° to the right for optimal

adjustment of L lamp housings and a straight position 11 504 108

Manual Mirror Housing

to accommodate two light sources, or fiber optic or laser couplings

Ergonomically angled 90° to the left for optimal

adjustment of regular lamp housings

and a straight position 11 504 109

Motorized Mirror Housing

to accommodate 3 light sources, or fiber optic or laser couplings

Ergonomically angled 90° to the left and right for optimal

adjustment of all Leica lamp housings

and a straight position 11 504 107

Booster Lens

Depending on the application, a 180° turn of the switchable auxiliary lens (booster) provides either maximum fluorescence intensity (factor: 1.4x in 75% center of field) or optimal homogeneity and brightness distribution (factor: 0.7x for the entire field).

Suitable for insertion into the stand on the right or left, depending on order.

11 522 027

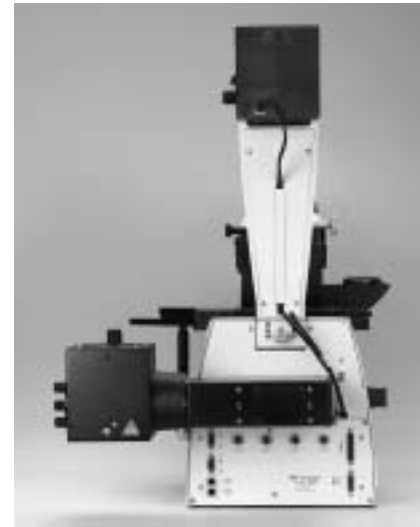

Fig. 86: Rear view of stand with lamp mount



Fig. 87: Booster lens



Fig. 88: Fluorescence block A4

Fluo Filter Systems

Insertion into the fluorescence or reflector disk does not require any tools. On the basis of high-precision manufacturing, during changing (e.g. for multi-wave technique) no evident image misalignment occurs (Zero Pixel Shift).

• Filter system A	11 513 873
• Filter system A4	11 513 874
• Filter system D	11 513 875
• Filter system E4	11 513 876
• Filter system H3	11 513 877
• Filter system I3	11 513 878
• Filter system K3	11 513 879
• Filter system L5	11 513 880
• Filter system M2	11 513 881
• Filter system N2.1	11 513 882
• Filter system N3	11 513 883
• Filter system G/R	11 513 884
• Filter system TX2	11 513 885
• Filter system B/G/R	11 513 886
• Filter system Y3	11 513 887
• Filter system Y5	11 513 888
• Filter system Y7	11 513 889
• Filter system GFP	11 513 890
• Filter system FI/RH	11 513 891
• Filter system CFP	11 513 892
• Filter system YFP	11 513 893
• Filter system Red RFP	11 513 894
• Filter system BFP/GFP	11 513 895
• Filter system CFP/YFP	11 513 896
• Filter system C/Y/R	11 513 897
• Filter system POL, IGS	11 513 898
• Filter system blank system	11 513 899

Light Sources, Lamp Housing, Supply Units

The light sources are housed in lamp mounts, which are housed in lamp housings. The lamp housings are fastened to the stand or transmitted light illumination arm using a flange ring. This allows optimum heat decoupling and comfortable handling. The following equipment is available:

For Transmitted Light:

Standard Lamp Housing

Lamp Housing 107/2 (Single-lens)

Plastic lamp housing with lamp access from above. With fixed, pre-centered lamp mount with 0.70 m power cable including 1x halogen bulb 12 V 100 W, single-lens aspherical, permanently set collector, heat-absorbing filter, microprism grid disk with middle diffuser for enlargement of the lamp filament and optimization of the illuminated area, without reflector, without replacement lamp. 11 504 104

Lamp Housing 107/2 (Single-lens)

as above, but with 2.5 m power cable 11 504 103

Lamp Housing 107, Left-hand Operation (Double-lens)

Plastic lamp housing with lamp access from above. With centerable lamp mount with 0.70 m power cable including 1x halogen bulb 12 V 100 W, double-lens aspherical, focusable collector, heat-absorbing filter, microprism with middle diffuser for enlargement of the lamp filament and optimization of the illuminated area, without reflector, without replacement lamp. 11 504 102

Lamp Housing 107, Left-hand Operation (Double-lens)

as above, but with 2.5 m power cable 11 504 101

Lamp Housing 106 (Double-lens)

Metal lamp housing with side lamp access. With centerable lamp mount with 0.70 m power cable including 1x halogen bulb 12 V 100 W, double-lens aspherical, focusable collector, heat-absorbing filter, microprism with middle diffuser for enlargement of the lamp filament and optimization of the illuminated area, without reflector, without replacement lamp. 11 504 058

Lamp Housing 106 (Double-lens)

as above, but with 2.5 m power cable 11 504 059



Fig. 89: Lamp housing 107/2 (single-lens)



Fig. 90: Lamp housing 107 (double-lens)



Fig. 91: Lamp housing 106 (double-lens)



Fig. 92: Lamp housing 106z – 12 V 100 W (4 lens)



Fig. 93: Halogen bulb 12 V, 100 W for lamp housing 106z



Fig. 94: Lamp mount for Hg 50 W



Fig. 95: Lamp mount for Hg 100 W

Lamp Housing 106z, Left-Hand Operation – 12 V 100 W (4-lens)

Metal lamp housing with side lamp access.

With centerable lamp mount with 0.70 m power cable including 1x halogen bulb 12 V 100 W, four-lens, achromatic, focusable collector, centerable reflector for doubling of the lamp filament and optimization of the illuminated area, with heat-absorbing filter, without auxiliary lamp.

11 504 091

Lamp Housing 106z – 12 V 100 W (4 lens)

As 11 504 091, but right-hand operation.

11 504 070

For Incident Light (Fluorescence):

Lamp Housing 106z, Left-hand Operation – Hg 100 W (6-lens)

Metal lamp housing with side lamp access. Left-hand operation for DMI 6000 B.

With centerable lamp mount for Hg 100 W lamp with 1.5 m power cable.

6-lens, achromatic 1-inch collector, UV-optimized transmission > 50% at 340 nm, centerable reflector for doubling the focal point and optimization of the illuminated area, with heat-absorbing filter, without burner.

11 504 106

Lamp Housing 106z– Hg 100 W (6-lens)

As 11 504 106, but right-hand operation.

11 504 114

Lamp Housing 106z – Xe 75 W (6-lens)

Metal lamp housing with side lamp access.

With centerable lamp mount for Xe 75 W lamp with 1.5 m power cable.

6-lens, achromatic 1-inch collector, UV-optimized transmission > 50% at 340 nm, centerable reflector for doubling the focal point and optimization of the illuminated area, with heat-absorbing filter, face protection, protective gloves, without burner.

11 504 105

Fiber Optic Coupling

A fiber optic coupling can be inserted between the lamp mount and lamp housing. This "cold" light source prevents the stand from warming up and is also useful in conjunction with large climate chambers.

- **Fiber optic coupling, complete with 1 m light guide** 11 504 112
- **Fiber optic coupling, complete with 2 m light guide** 11 504 113

Lamps and Burners

- **Halogen bulb 12 V 100 W** (Fig. 93 p. 38) 11 500 974
- **High-pressure mercury burner Hg 100 W**
(Fig. 95 p. 38) 11 500 138
- **High-pressure mercury burner Hg 100 W/2**
(longer life) 11 500 321
- **High-pressure xenon burner Xe 75 W** 11 500 139

Spacer for Filter D = 50mm

2 filter positions at LH 106/107, 4 filter positions with LH 106 z.
adapter between LH. 11 505 030

Additionally, for Xe 75 W lamp:

Gray Filter 0.2%

D = 50 mm, 0.2% transparency, in holder 11 514 031

Diffusion Filter N

D = 50 mm, embossed, in holder. 11 514 042

Additional filters D = 50mm in holder:

- DLF, daylight filter 11 514 755
- ALF, artificial light filter 11 514 756
- Panchromatic green filter 11 542 131
- VG 9, green filter 11 514 041
- Neutral gray filter N20 (5%) 11 514 036
- Heat-absorbing filter 11 514 027

Supply Units

For power supply voltages other than 220–240 V, the following is required:

Pre-transformer 100–120 V

With power supply cord, primary 100–120 V, secondary
220–230 V 11 500 316

Supply Unit Hg 100 W

With power supply cord, automatic switching to power supply
voltage 90 V–250 V 50/60 Hz with operating hours display.
11 500 325

Supply Unit Xe 75 W

With power supply cord, automatic switching to power supply
voltage 90 V–250 V 50/60 Hz with operating hours display.
11 500 324



Fig. 96: Filter and spacer for filter d = 50mm



Fig. 97: Polarizer protective filter



Fig. 98: Supply unit Hg 100 W



Fig. 101: TV adapter



Fig. 102: TV adapter

TV Adapter

You can adapt analog and digital cameras to all tubes with documentation output. The C-B and F-mount adapters are aligned to the dimensions of the holder thread. The various fixed and variable magnification factors allow adjustment of the rendering of the microscopic image on the camera chip. In order to display the largest possible portion of the field of view on the monitor, the magnification factor of the adapter must fit the chip size of the camera. If the magnification is too low, there will be a lack of uniformity to the illuminated area (shading) and/or vignetting.

	Diagonal measurements of images taken (in mm) at				Order No.
	1 inch-Camera	2/3 inch-Camera	1/2 inch-Camera	1/3 inch-Camera	
Without variable magnification, only for single chip cameras:					
C-mount adapter 1x HC	16	11	8	6	11 541 510
C-mount adapter 0.63x HC	–	17.5	12.7	9.5	11 541 537
C-mount adapter 0.5x HC	–	–	16	19	11 541 511
C-mount adapter 0.35x HC	–	–	–	17.1	11 541 512
With variable magnification (Vario TV adapter) for 1–3 chip cameras:					
C-mount, 0.32–1.6x HC	–	–	19*–5	18–3.8	11 541 517
B-mount (ENG), 0.5–2.4x HC (1/2 inch)	–	–	16–3.3	–	11 541 518
Without variable magnification level, only for 1-3 chip cameras:					
C-mount adapter 1x	–	–	16	12	11 543 706
B-mount adapter 1x	–	–	16	12	11 543 702
B-mount adapter 1.25x	–	17.5	–	–	11 541 539
F-mount adapter 1x	–	–	16	12	11 541 540
F-mount adapter 1.25x	–	17.5	–	–	11 541 541
Required for each: TV optics 0.5x HC					11 541 538

* Available beginning with Vario factor 0.42x!



Fig. 103:
C-mount 0.63x HC



Fig. 103:
C-mount 0.5x HC

Objectives, Objective Turret, Optics

Objectives

Based on the Leica principle of infinity distance correction of optics, the microscope objectives are infinity corrected for tube lens systems with 200 mm reference focal lengths. The calibration length is 45 mm for bright field.

The objectives are divided into 4 correction classes:

- Achromatic objectives: C PLAN
Field of view performance up to FOV 20
- Planachromatic objectives: N PLAN
Field of view performance up to FOV 22
- Semi-apochromatic objectives: HC/X PL FLUOTAR
Field of view performance up to FOV 25
- Apochromatic objectives HC/X PL APO
Field of view performance up to FOV 25

When selecting the objectives, consider the intended use with regard to specimen covering, etc. For more detailed explanations, please refer to the appendix of the objective list.

Objective Turret

In principle, all infinity corrected high-performance Leica objectives with an M25 thread may be used. Even older objectives can be adapted for further use. An adapter is available for RMS-threaded objectives:

- Adapter M25/RMS 11 506 028
- Adapter M32/M25 11 561 003
- Adapter M32/RMS 11 562 281

A wide range of application objectives with long working distances (L objectives) and/or with corrective mounts (Corr objectives) are available especially for inverted microscopy. The following table lists all objectives of the Leica program. The specimen is focused via the 6-position M25 objective turret. The reliable, stable and precise focusing is not affected by the stage and its specimens or accessories.

Adapters are available for the installation of objectives with different thread sizes. Objectives of earlier lines with RMS threads cannot be adapted unconditionally, however, as problems with parfocality and field flattening may arise.

Optics

The optics are the heart of every microscope and influence the quality of the image information. Leica has set standards in this respect with the introduction of HC optics. Eyepieces, tube lenses, and objectives have been carefully harmonized with one another.



Fig. 104: HCX PL Fluotar 63x/0.90 Corr



Fig. 105: Objective turret

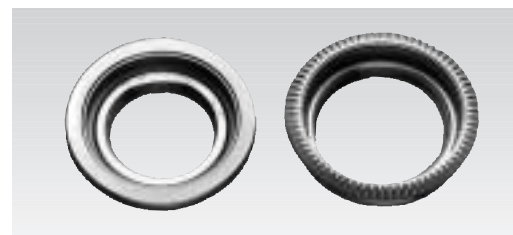

Fig. 106: Adapter for RMS-threaded objectives

Leica HCS Objectives, Version 3.8

Objective type	Magnification/Aperture	Im-mer-sion	Technique	Cover glass	Interference contrast prisms						Objective thread	Free working distance (mm)	Article No.
					ICT					ICR			
					Upright	S 1-Cond.	S 23-Cond.	S 70-Cond.	Obj.				
HXC PL FLUOTAR	1.25x/0.04		17	-	-	-	-	-	-	M25	3.7	11506215	
HXC PL FLUOTAR	1.25x/0.04		17	0	-	-	-	-	-	M25	2.0	11566045	
PL FLUOTAR	1.6x/0.05			-	-	-	-	-	-	M25	3.4	11506053	
PL FLUOTAR	1.6x/0.05		1	-	-	-	-	-	-	M25	1.54	11566010	
N PLAN	2.5x/0.07			-	-	-	-	-	-	M25	11.2	11506083	
N PLAN	2.5x/0.07		P	-	-	-	-	-	-	M25	11.2	11556036	
PL FLUOTAR	2.5x/0.07			-	-	-	-	-	-	RMS	9.2	11567010	
C PLAN	4x/0.10			-	-	-	-	-	-	M25	26.2	11506074	
C PLAN	4x/0.10		POL	-	-	-	-	-	-	M25	26.2	11556030	
HI PLAN	4x/0.10			-	-	-	-	-	-	M25	18.0	11506226	
HI PLAN	4x/0.10		SL	-	-	-	-	-	-	M25	18.0	11506227	
HI PLAN	4x/0.10		POL	-	-	-	-	-	-	M25	18.0	11556060	
N PLAN	5x/0.12			-	-	-	-	-	-	M25	14.0	11506087	
N PLAN	5x/0.12		PH0/	-	-	-	-	-	-	M25	14.0	11506090	
N PLAN	5x/0.12		P	-	-	-	-	-	-	M25	14.0	11556039	
N PLAN	5x/0.12		BD	-	-	-	-	-	-	M32	13.2	11566016	
HC PL FLUOTAR	5x/0.15		13	-	-	-	-	-	-	M25	12.0	11506504	
HXC PL FLUOTAR	5x/0.15		13	-	-	-	-	-	-	M25	12.0	11506224	
HC PL FLUOTAR	5x/0.15		P	-	-	-	-	-	-	M25	12.0	11556502	
HXC PL FLUOTAR	5x/0.15		P	-	-	-	-	-	-	M25	12.0	11556058	
HC PL FLUOTAR	5x/0.15		BD	-	-	-	-	-	-	M32	12.2	11566506	
HXC PL FLUOTAR	5x/0.15		BD	-	-	-	-	-	-	M32	12.2	11566046	
HXC PL FLUOTAR	5x/0.15		XT	-	-	-	-	-	-	M32	12.2	11506225	
C PLAN	10x/0.22		13)	-	-	-	-	-	-	M25	7.8	11506075	
C PLAN	10x/0.22		PH1/13	-	-	-	-	-	-	M25	7.8	11506078	
C PLAN	10x/0.22		LMC	-	-	-	-	-	-	M25	7.8	11506138	
C PLAN	10x/0.22		POL	-	-	-	-	-	-	M25	7.8	11556031	
HI PLAN	10x/0.25			-	-	-	-	-	-	M25	12.0	11506228	
HI PLAN	10x/0.25		SL	-	-	-	-	-	-	M25	12.0	11506229	
HI PLAN	10x/0.25		PH1	-	-	-	-	-	-	M25	12.0	11506230	
HI PLAN	10x/0.25		POL	-	-	-	-	-	-	M25	12.0	11556061	
HI PLAN CY	10x/0.25			-	-	-	-	-	-	M25	11.0	11506244	
HI PLAN CY	10x/0.25		SL	-	-	-	-	-	-	M25	11.0	11506245	
HI PLAN CY	10x/0.25		PH1	-	-	-	-	-	-	M25	11.0	11506246	
N PLAN	10x/0.25		3	-	-	-	-	-	-	M25	5.8	11506084	
N PLAN	10x/0.25		PH1/3	-	-	-	-	-	-	M25	5.8	11506088	
N PLAN	10x/0.25		P 3	-	-	-	-	-	-	M25	5.8	11556038	
N PLAN	10x/0.25		BD	-	-	-	-	-	-	M32	5.2	11566005	
HC PL FLUOTAR	10x/0.30			-	-	-	-	-	-	M25	11.0	11506505	
HC PL FLUOTAR	10x/0.30		PH1/	-	-	-	-	-	-	M25	11.0	11506507	
HC PL FLUOTAR	10x/0.30		P	-	-	-	-	-	-	M25	11.0	11556503	
HC PL FLUOTAR	10x/0.30		BD	-	-	-	-	-	-	M32	11.0	11566503	
HXC APO L U-V-12	10x/0.30		W	2	-	-	-	-	-	M25	3.6	11506142	
HC PL APO CS	10x/0.40		/14	0.17	-	-	-	-	-	M25	2.2	11506511	
HC PLAN APO	10x/0.40		/	0.17	-	-	-	-	-	M25	2.2	11506165	
HC PLAN APO	10x/0.40		PH1/	0.17	-	-	-	-	-	M25	2.2	11506169	
HC PL APO	10x/0.40		IMM	-	-	-	-	-	-	M25	0.36	11506512	
HC PL APO CS	10x/0.40		IMM	14	-	-	-	-	-	M25	0.36	11506177	
C PLAN	20x/0.40		/	0.17	-	-	-	-	-	M25	2.30	11506076	
C PLAN	20x/0.40		PH1/	0.17	-	-	-	-	-	M25	2.30	11506079	
HI PLAN	20x/0.40		/	0.17	-	-	-	-	-	M25	2.32	11506235	
HI PLAN	20x/0.40		PH1/	0.17	-	-	-	-	-	M25	2.32	11506239	
C PLAN L	20x/0.30		0-2	-	-	-	-	-	-	M25	4.5-3.1	11506055	
C PLAN L	20x/0.30		LMC	0-2	-	-	-	-	-	M25	4.5-3.1	11506136	
C PLAN L	20x/0.30		13	0-2	-	-	-	-	-	M25	3.7-2.4	11506151	

Objective type	Magnification/Aperture	Im-mer-sion	Technique	Cover glass	Interference contrast prisms						Objective thread	Free working distance (mm)	Article No.	
					ICT					ICR				
					Upright	S 1-Cond.	S 23-Cond.	S 70-Cond.	Obj.					
C PLAN L	20x/0.30		PH1/13	0-2	-	-	-	-	-	M25	3.7-2.4	11506152		
C PLAN L	20x/0.30		LMC	0-2	-	-	-	-	-	M25	3.7-2.4	11506154		
N PLAN	20x/0.40		/13	0.17	K ₂ +D	K ₃ (K ₁)	K ₆ (K ₃)	K ₈ (K ₃)	D(D)	-	M25	0.39	11506096	
N PLAN	20x/0.40		PH1/13	0.17	K ₂ +D	K ₃ (K ₁)	K ₆ (K ₃)	K ₈ (K ₃)	D(D)	-	M25	0.39	11506098	
N PLAN	20x/0.40			0	K ₂ +D	-	-	-	-	D ₁ /D ₅	M25	1.1	11566026	
N PLAN	20x/0.40		P	0	K ₂ +D	-	-	-	-	D ₁ /D	M25	1.1	11556043	
N PLAN	20x/0.40		BD	0	-	-	-	-	-	D ₁ /D ₅	M32	1.1	11566029	
N PLAN L	20x/0.40		CORR	13	0-2	K ₂ +C	K ₁₁	K ₃	K ₆	C	C	M25	3.2-1.9	11506200
N PLAN L	20x/0.40		CORR	PH1/13	0-2	K ₂ +C	K ₁₁	K ₃	K ₆	C	C	M25	3.2-1.9	11506202
N PLAN L	20x/0.40		CORR	LMC	0-2	-	-	-	-	-	-	M25	3.2-1.9	11506134
N PLAN L	20x/0.40		CORR	LMC	0-2	-	-	-	-	-	-	M25	3.2-1.9	11506204
N PLAN L	20x/0.40			0	-	-	-	-	-	-	C	M25	10.8	11566035
N PLAN L	20x/0.40			0	-	-	-	-	-	-	C	M25	10.8	11566049
N PLAN L	20x/0.40		BD	0	-	-	-	-	-	-	C	M32	10.8	11566037
N PLAN L	20x/0.40		BD	0	-	-	-	-	-	-	C	M32	10.8	11566051
N PLAN H	20x/0.40			1.8 Q	-	-	-	-	-	-	-	M25	10.6	11566039
HC PL FLUOTAR	20x/0.50		/	0.17	-	-	-	-	-	-	-	M25	1.15	11506503
HC PL FLUOTAR	20x/0.50		PH2/	0.17	-	-	-	-	-	-	-	M25	1.15	11506506
HC PL FLUOTAR	20x/0.50		P	0.17	-	-	-	-	-	-	-	M25	1.15	11556501
HC PL FLUOTAR	20x/0.50			0	-	-	-	-	-	-	D ₁ /D	M25	1.27	11566500
HC PL FLUOTAR	20x/0.50		BD	0	-	-	-	-	-	-	D ₁ /D	M32	1.27	11566507
PL FLUOTAR L	20x/0.40		BD	0	-	-	-	-	-	-	C	M32	10.7	11766001
HXC APO L U-V-11	20x/0.50		W	2	-	-	-	-	-	-	-	M25	3.5	11506147
HC PL APO CS	20x/0.70		/14	0.17	K ₂ +C	K ₁₁	K ₃	K ₆	C	-	-	M25	0.59	11506513
HC PLAN APO	20x/0.70		/	0.17	K ₂ +C	K ₁₁	K ₃	K ₆	C	-	-	M25	0.59	11506166
HC PLAN APO	20x/0.70		PH2/	0.17	K ₂ +C	K ₁₁	K ₃	K ₆	C	-	-	M25	0.59	11506170
HC PL APO	20x/0.70		IMM/CORR	/14	Lbd. Bl ¹⁵	-	-	-	-	-	-	M25	0.26 with W and 0.17	11506191
HC PL APO CS	20x/0.70		IMM/CORR	14	-	-	-	-	-	-	-	M25	0.26 with W and 0.17	11506178
C PLAN	40x/0.65			0.17	-	-	-	-	-	-	-	M25	0.31	11506077
C PLAN	40x/0.65		PH2/	0.17	-	-	-	-	-	-	-	M25	0.31	11506080
C PLAN	40x/0.65		POL	0.17	-	-	-	-	-	-	-	M25	0.31	11556032
HI PLAN	40x/0.65			0.17	-	-	-	-	-	-	-	M25	0.36	11506236
HI PLAN	40x/0.65		PH2/	0.17	-	-	-	-	-	-	-	M25	0.36	11506240
HI PLAN	40x/0.65		POL	0.17	-	-	-	-	-	-	-	M25	0.36	11556065
C PLAN L	40x/0.50		/13	1.1	-	-	-	-	-	-	-	M25	2.0	11506149
C PLAN L	40x/0.50		PH2/13	1.1	-	-	-	-	-	-	-	M25	2.0	11506150
C PLAN L	40x/0.50		LMC	1.1	-	-	-	-	-	-	-	M25	2.0	11506153
N PLAN	40x/0.65		/13	0.17	-	-	-	-	-	-	-	M25	0.36	11506097
N PLAN	40x/0.65		PH2/13	0.17	-	-	-	-	-	-	-	M25	0.36	11506099
N PLAN L	40x/0.55		CORR	/13	0-2	K ₂ +C	K ₃	K ₆	K ₈	C	C	M25	3.3-1.9	11506218
N PLAN L	40x/0.55		CORR	PH2/13	0-2	K ₂ +C	K ₃	K ₆	K ₈	C	C	M25	3.3-1.9	11506219
N PLAN L	40x/0.55		CORR	LMC	0-2	-	-	-	-	-	-	M25	3.3-1.9	11506135
HXC PL FL L	40x/0.60		CORR	/13	0-2	K ₂ +C	K ₃	K ₆	K ₈	C	C	M25	3.3-1.9	11506201
HXC PL FL L	40x/0.60		CORR	XT 13	0-2	K ₂ +C	K ₃	K ₆	K ₈	C	C	M25	3.3-1.9	11506208
HXC PL FL L	40x/0.60		CORR	PH2/13	0-2	K ₂ +C	K ₃	K ₆	K ₈	C	C	M25	3.3-1.9	11506203
HXC PL FL L	40x/0.60		CORR	PH2/XT 13	0-2	K ₂ +C	K ₃	K ₆	K ₈	C	C	M25	3.3-1.9	11506209
HXC PL FL L	40x/0.60		CORR	LMC	0-2	-	-	-	-	-	-	M25	3.3-1.9	11506205
HXC PL FLUOTAR	40x/0.75		/	0.17	-	-	-	-	-	-	-	M25	0.40	11506144
HXC PL FLUOTAR	40x/0.75		PH2/	0.17	-	-	-	-	-	-	-	M25	0.40	11506145
HXC PL FLUOTAR	40x/0.75		P/	0.17	-	-	-	-	-	-	-	M25	0.40	11556052
PL FLUOTAR	40x/1.00-0.50		OIL	/	-	-	-	-	-	-	-	M25	0.08	11506007
PL FLUOTAR	40x/1.00		OIL	PH3/	-	-	-	-	-	-	-	M25	0.08	11506016
HXC APO L U-V-12	40x/0.80		W	2	0	K ₂ +D ₁	-	-	-	-	-	M25	3.3	11506155
HXC PL APO U-V-12	40x/0.75			0.17	-	-	-	-	-	-	-	M25	0.28	11506173
HXC PLAN APO	40x/0.75		PH2/	0.17	-	-	-	-	-	-	-	M25	0.28	11506174

Objective type	Magnification/Aperture	Im-mer-sion	Technique	Cover glass	Interference contrast prisms						Objective thread	Free working distance (mm)	Article No.
					ICT					ICR			
					Upright	Inverse (IRB HC)							
S 1-Cond.	S 23-Cond.	S 70-Cond.	Obj.										
HXC PL APO CS	40x/0.85	CORR	/ ¹⁴	0.11-0.23	K ₃ +C	K ₃	K ₆	K ₈	C	-	M25	0.24	11506140
HXC PLAN APO	40x/0.85	CORR	/	0.11-0.23	K ₃ +C	K ₃	K ₆	K ₈	C	-	M25	0.24	11506167
HXC PL APO	40x/ 1.25-0.75	OIL	/	0.17	K ₃ +E or K ₃ +E ₁₁	K ₃	K ₇	-	E	-	M25	0.1	11506105
HXC PL APO CS		OIL	/ ¹⁴	0.17		K ₆	K ₇	-	E	-	M25	0.1	11506179
HXC PL APO	40x/1.25	OIL	PH3/	0.17	K ₃ +E or K ₃ +E ₁₁	K ₃	K ₇	-	E	-	M25	0.1	11506106
HXC PL APO CS	40x/1.25	OIL	PH3/ ¹⁴	0.17		K ₃	K ₇	-	E	-	M25	0.1	11506181
	50x/0.75	W	/	0.17	-	-	-	-	-	-	M25	0.12	11506049
N PLAN	50x/0.75			0	-	-	-	-	-	D(D) ₁ ⁵	M25	0.37	11506027
N PLAN	50x/0.75			0	-	-	-	-	-	D(D) ₁ ⁵	M25	0.37	11506050
N PLAN	50x/0.75			0	-	-	-	-	-	D	M25	0.38	11506008
N PLAN	50x/0.75	P		0	-	-	-	-	-	D(D) ₁	M25	0.37	11506044
N PLAN	50x/0.75	P		0	-	-	-	-	-	D(D) ₁	M25	0.37	11506062
N PLAN	50x/0.75	BD		0	-	-	-	-	-	D(D) ₁ ⁵	M32	0.37	11506030
N PLAN	50x/0.75	BD		0	-	-	-	-	-	D(D) ₁ ⁵	M32	0.37	11506052
N PLAN	50x/0.90	OIL	/	-	-	-	-	-	-	-	M25	0.14	11506085
N PLAN L	50x/0.50			0	-	-	-	-	-	C	M25	8.2	11506036
N PLAN L	50x/0.50	BD		0	-	-	-	-	-	C	M25	8.1	11506038
N PLAN H	50x/0.50			1.8 Q	-	-	-	-	-	-	M25	7.1	11506040
HC PL FLUOTAR	50x/0.80			0	-	-	-	-	-	D(D) ₁	M25	0.5	11506501
HC PL FLUOTAR	50x/0.80	BD		0	-	-	-	-	-	D(D) ₁	M32	0.5	11506504
PL FLUOTAR L	50x/0.55			0	-	-	-	-	-	C	RMS	8.0	11767002
PL FLUOTAR L	50x/0.55	BD		0	-	-	-	-	-	C	M32	8.0	11766000
PL APO	50x/0.90			0	-	-	-	-	-	C	RMS	0.28	11506034
PL APO	50x/0.85	BD		0	-	-	-	-	-	C	M32	0.34	11506013
C PLAN	63x/0.75	/		0.17	-	-	-	-	-	-	M25	0.31	11506100
C PLAN	63x/0.75	P/		0.17	-	-	-	-	-	-	M25	0.31	11506037
HI PLAN	63x/0.75	/		0.17	-	-	-	-	-	-	M25	0.31	11506237
HI PLAN	63x/0.75	POL		0.17	-	-	-	-	-	-	M25	0.31	11506066
PL FLUOTAR L	63x/0.70	CORR	¹³	0.1-1.3	K ₃ +C or K ₃ +C ¹¹	K ₃	K ₇	-	C	C	M25	2.6-1.8	11506061
HXC PL FLUOTAR L	63x/0.70	CORR	¹³	0.1-1.3		K ₃	K ₇	-	C	C	M25	2.6-1.8	11506216
PL FLUOTAR L	63x/0.70	CORR	PH2/ ¹³	0.1-1.3		K ₃	K ₇	-	C	-	M25	2.6-1.8	11506062
HXC PL FLUOTAR L	63x/0.70	CORR	PH2/ ¹³	0.1-1.3		K ₃	K ₇	-	C	-	M25	2.6-1.8	11506217
HXC PL FLUOTAR L	63x/0.70	CORR	XT ¹³	0.1-1.3	-	-	-	-	-	-	M25	2.6-1.8	11506222
PL FLUOTAR L	63x/0.70	CORR	LMC	0.1-1.3	-	-	-	-	-	-	M25	2.6-1.8	11506146
N PLAN	63x/0.80	/		0.17	K ₃ +D	K ₃	K ₇	-	D	-	M25	0.26	11506184
N PLAN	63x/0.80	P		0	K ₃ +D	K ₃	K ₇	-	D	-	M25	0.26	11506056
HXC APO L U-V- ¹²	63x/0.90	W	²	0	K ₃ +D ₁	-	-	-	-	-	M25	2.2	11506148
HXC PL FLUOTAR	63x/0.90	CORR	²	0	K ₃ +D ₁	-	-	-	-	-	M25	0.28	11506223
HXC PL FLUOTAR	63x/1.25	OIL	/	0.17	K ₄ +E	K ₄	K ₁₀	-	E	-	M25	0.19	11506185
HXC PL FLUOTAR	63x/1.25	OIL	PH3/	0.17	K ₄ +E	K ₄	K ₁₀	-	E	-	M25	0.19	11506186
HXC PL APO	63x/1.30	GLYC 37°C	/	0.14-0.18	K ₄ +D ₁ or K ₄ +D ₁ pitoc ¹¹	K ₄ or K ₄ +D ₁ or K ₄ +D ₁ pitoc ¹¹	-	-	-	-	M25	0.28	11506193
HXC PL APO CS	63x/1.30	GLYC 21°C	/ ¹⁴		K ₄ +E or K ₄ +E ¹¹	K ₄	K ₁₀	-	E	-	M25	0.28	11506194
HXC PL APO	63x/1.40-0.60	OIL	/	0.17	K ₄	K ₁₀	-	E	-	M25	0.10	11506187	

Objective type	Magnification/Aperture	Im-mer-sion	Technique	Cover glass	Interference contrast prisms						Objective thread	Free working distance (mm)	Article No.	
					ICT					ICR				
					Upright	Inverse (IRB HC)								
S 1-Cond.	S 23-Cond.	S 70-Cond.	Obj.											
HXC PL APO CS	63x/ 1.32-0.60	OIL	/ ¹⁴	0.17	K ₄ +D or K ₄ +D ¹¹	K ₄	K ₇	-	D	-	M25	0.07	11506180	
HXC PL APO CS	63x/1.40-0.60	OIL	/ ¹⁴	0.17	K ₄ +E or K ₄ +E ¹¹	K ₄	K ₁₀	-	E	-	M25	0.10	11506188	
HXC PL APO	63x/1.40-0.60	OIL	/	0.17	K ₄ +D or K ₄ +D ¹¹	K ₄	K ₇	-	E	-	M25	0.10	11506192	
HXC PL APO	63x/1.20	W CORR ¹¹	/ ¹⁴ Ltd. B ¹⁵	0.14-0.18		K ₄	K ₇	-	D	-	M25	0.22	11506190	
HXC PL APO	63x/1.20	W CORR ¹¹	/ ¹⁴ Ltd. B ¹⁵	0.14-0.18	K ₄ +D or K ₄ +D ¹¹	K ₄	K ₇	-	D	-	M25	0.22	11506213	
HXC PL APO CS	63x/1.40	OIL	PH3/	0.17		K ₄ +E or K ₄ +E ¹¹	K ₄	K ₁₀	-	E	-	M25	0.1	11506206
HXC PL APO CS	63x/1.32	OIL	PH3/ ¹⁴	0.17	K ₄ +D or K ₄ +D ¹¹	K ₄	K ₇	-	D	-	M25	0.07	11506182	
HXC PL APO CS	63x/1.20	W CORR ¹¹	/ ¹⁴	0.14-0.18		K ₄	K ₇	-	D	-	M25	0.22	11506131	
HXC PL APO CS	63x/1.20	W CORR ¹¹	/ ¹⁴	0.14-0.18	K ₄ +D or K ₄ +D ¹¹	K ₄	K ₇	-	D	-	M25	0.22	11506212	
C PLAN	100x/1.25	OIL	/	0.17		-	-	-	-	-	-	M25	0.10	11506072
C PLAN	100x/1.25	OIL	PH3/	0.17	-	-	-	-	-	-	M25	0.10	11506073	
HI PLAN	100x/1.25	OIL	/	0.17	-	-	-	-	-	-	M25	0.10	11506238	
HI PLAN	100x/1.25	OIL	PH3/	0.17	-	-	-	-	-	-	M25	0.10	11506241	
N PLAN	100x/0.90			0	-	-	-	-	-	D(D) ₁ ⁵	M25	0.27	11506028	
N PLAN	100x/0.90	BD		0	-	-	-	-	-	D(D) ₁ ⁵	M32	0.30	11506031	
N PLAN	100x/1.25	OIL	/ ¹³	-	K ₄ +D or K ₄ +D ¹¹	K ₁₀	-	D	-	-	M25	0.12	11506158	
N PLAN	100x/1.25-0.60	OIL	/ ¹³	0.17		K ₁₀	-	D	-	-	M25	0.12	11506207	
N PLAN	100x/1.25	OIL	PH3/ ¹³	-		K ₁₀	-	D	-	-	M25	0.12	11506159	
N PLAN	100x/1.25	OIL	P	-		K ₁₀	-	D	D(D) ₁	-	M25	0.12	11506053	
HXC PL FLUOTAR	100x/1.30	OIL	RC	-	-	-	-	-	-	-	M25	0.13	11506163	
HC PL FLUOTAR	100x/0.90			0	K ₄ +D	-	-	-	-	D(D) ₁	M25	0.27	11506502	
HC PL FLUOTAR	100x/0.90	BD		0	K ₄ +D	-	-	-	-	D(D) ₁	M32	0.30	11506505	
PL FLUOTAR L	100x/0.90	P		0	K ₄ +D or K ₄ +D ¹¹	K4(K10)	K ₁₀	-	D	D(D) ₁	M25	0.27	11506057	
PL FLUOTAR L	100x/0.75			0	-	-	-	-	-	-	RMS	4.7	11767000	
HXC PL FLUOTAR	100x/1.30	OIL		0.17	K ₄ +D	K ₄ or K ₄ ¹¹	K ₁₀	-	D	D(D) ₁	M25	0.13	11506195	
HXC PL FLUOTAR	100x/1.30	OIL		0	-	-	-	-	-	D(D) ₁	M25	0.22	11506164	
HXC PL FLUOTAR	100x/1.30	OIL		0	K ₄ +D or K ₄ +D ¹¹	-	-	-	-	-	D(D) ₁	M25	0.22	11506199
HXC PL FLUOTAR	100x/1.30	OIL		0.17		K ₄ or K ₄ ¹¹	K ₁₀	-	D	D(D) ₁	M25	0.13	11506196	
HXC PL FLUOTAR	100x/1.30	OIL	PH3/	0.17		K ₄ or K ₄ ¹¹	K ₁₀	-	D	D(D) ₁	M25	0.13	11506197	
HXC APO U-V- ¹²	100x/1.30	OIL		0.17		K ₄ or K ₄ ¹¹	K ₁₀	-	D	D(D) ₁	M25	0.12	11506156	
PL APO	100x/0.95			0	K ₄ +C	-	-	-	-	C	RMS	0.16	11506023	
PL APO	100x/0.90	BD		0	K ₄ +C	-	-	-	-	C	M32	0.26	11506014	
HXC PL APO CS	100x/1.40-0.70	OIL	/ ¹⁴	0.17	K ₄ +D or K ₄ +D ¹¹	K ₁₀	-	D	-	-	M25	0.09	11506210	
HXC PL APO CS	100x/1.40	OIL	PH3/	0.17		K ₁₀	-	D	-	-	M25	0.09	11506211	
HXC PLAN APO	100x/1.35	OIL	/	0.17	K ₄ or K ₄ ¹¹	K ₁₀	-	D	-	-	M25	0.09	11506168	
HXC PL APO	100x/1.40-0.70	OIL	/	0.17		K ₁₀	-	D	-	-	M25	0.09	11506220	
HXC PL APO CS	100x/1.40	OIL	PH3/ ¹⁴	0.17		K ₁₀	-	D	-	-	M25	0.09	11506042	
HXC PLAN APO	100x/1.35	OIL	PH3/	0.17		K ₁₀	-	D	-	-	M25	0.09	11506172	
HXC PLAN APO	100x/1.35	OIL	PH3/	0.17	K ₄ +D (K ₁₀ +D ₁) or K ₄ +D ¹¹	K ₁₀	-	D	-	-	M25	0.09	11506221	
HXC PL FLUOTAR	150x/0.90			0		K ₄ +C	K ₄	K ₁₀	-	C	C	M25	0.25	11506214
PL APO	150x/0.95			0	-	-	-	-	-	C	RMS	0.20	11506042	
PL APO	150x/0.90	BD												

Tube length ∞ , Reference focal length tube length $f_B = 200\text{mm}$, calibration length 45mm

Immersion:

OIL = immersion oil as per DIN/ISO
IMM = water, glycerin or oil
W = water

Methods:

Suitable for transmitted light bright field, transmitted light darkfield, fluorescence and polarization contrast; no special labeling. Achromatic objectives C PLAN are only conditionally recommended for fluorescence.

BD = for brightfield/incident light-dark field
PH = phase contrast objective
RC = reflection contrast objective
L = long working distance
P, POL = low-strain, for quantitative polarization/
=not for incident light, with exception of fluorescence
LMC = modulation contrast objective (only with DM IRB)

IC prisms for interference contrast:

Condenser prisms:

K_{1a} only DMR with condensers UCR/UCPR,
condenser head swung out
 K_{1b} only with DM4000, DM4500, DM5000, DM6000 condensers,
condenser head swung out
 $K_2 - K_5 + K_{11}$ only with condenser head 0.90 S1 or P 0.90 S1
(upright)
 K_9, K_{12}, K_{15} only with condenser head P 1.40 OIL S1
Objective prisms: A – E
Prisms B_2/D for wider splitting = higher contrast
 B_1/D_1 for narrower splitting = higher resolution

Cover glass requirements:

– can be used with and without cover glass
0 for use without cover glass
0.17 for use with cover glass 0.17mm (DIN/ISO)
1.8 Q with quartz glass window 1.8mm, for use on heating stages
0 – 2 can be used with cover glasses from 0 – 2mm thick

Weakest objective magnification levels:

According to microscope/condenser type:

DM LS/LSP 4x/FOV 20; 5x/FOV 25
UCL/UCLP 2.5x/FOV 25 with auxiliary lens 2.5
CL/PH 2.5x with diffusion filter
DM LB/LP/LM 4x/FOV 20 or 5x/FOV 25
UCA/UCAP 1.6x/FOV 25
DMR series 1.6x all FOV (UCR/UCE/UCPR)
approx. 1x with Bertrand lens B (without objective) and special condenser

- ¹¹ With quartz plate for enhanced contrast (crossed polarizers required)
- ¹² Inert front section with minimal electrical and thermal conductivity, chemically neutral ceramics
- ¹³ Immersion cap for oil, water etc. available (11 556 045)
- ¹⁴ Capping piece CG 0.4 (11 506 071) for cover glass 0.25 – 0.55mm
- ¹⁵ For low-contrast incident light objectives alternative objectives N PLAN POL or HC PL FLUOTAR/PL APO
- ¹⁶ K_{1a} condenser prisms only with condenser UCR/stands DMR, condenser head swung out!
- ¹⁷ Correction for adjustment with/without cover glass/with water, glycerol, immersion oil
- ¹⁸ Correction for adaptation to cover glass thicknesses 0.14 – 0.18mm/temperature 15 – 37 °C/NaCl content 0 – 3 %
- ¹⁹ Correction for temperature 15–37 °C and NaCl 0–3 %
- ²⁰ With condenser head P 1.40 OIL S1
- ²¹ U-V-I: UV-Visible-IR
- ²² Appropriate and recommended for Leica Integrated Modulation Contrast (IMC)
- ²³ Optimized for Confocal Scanning
- ²⁴ Lbd. Bl (Lambda Blue): GFP optimized
- ²⁵ With piezo focus drive (Leica AS MDW)
- ²⁶ Recommended for Leica DM 4000, DM 5000, DM 6000

Adapters are required for objective threads that do not match the turret:
M25/RMS 11 506 028 M32/M25 11 561 003 M32/RMS 11 562 281

Accessories

Immersion oil, 20 ml

as per ISO 8036/1, refraction index $n_e^{23} = 1.5180 \pm 0.005$,
dispersion $v_e^{23} = 44 \pm 2$ 11 513 860

Immersion oil, 250 ml

as per ISO 8036/1, refraction index $n_e^{23} = 1.5180 \pm 0.005$,
dispersion $v_e^{23} = 44 \pm 2$ 11 513 861

Immersion oil, 10 ml

Free of natural fluorescence as per ISO 8036/1,
refraction index $n_e^{23} = 1.5180 \pm 0.005$,
dispersion $v_e^{23} = 44 \pm 2$ 11 513 859

Stage micrometer

Transmitted light 2 mm = 200 parts 11 513 106

Stage micrometer

Incident light 1 mm = 100 parts 11 563 011

Focusing telescope diameter 30.0mm

11 505 070

Halogen lamp 12 V 100 W

11 500 974

Hg 50 W burner

11 500 137

Hg 100 W/2 burner

11 500 321

Xe high-pressure burner

11 500 139



Fig. 107: Proper handling of Hg burner



Fig. 108: Proper handling of halogen lamp

Digital Image Documentation and Analysis

• Leica Digital Camera System DC150, DC180, DC300/350 DC480, DC500, D2DV3

Monochrome and color digital cameras for all requirements
between highest resolution (12 megapixels) and quick live image
(25 frames per second)
(see Leica Digital Camera brochures)

Leica Image Analysis Systems:

- **Leica CW4000**
Image analysis for cytogenetics
- **Leica Qprodit**
Image analysis for pathology
- **Leica FW4000**
Fluorescence imaging solutions
- **Leica Q550MW**
Image analysis for materials testing
(see Leica Image Analysis brochures)



Fig. 109: Micromanipulator with extension and single instrument holder

Micromanipulator

Mechanical micromanipulators are also available for all inverted Leica microscopes:

- **Micromanipulator (for right side of microscope)** 11 520 137
- **Micromanipulator (for left side of microscope)** 11 520 138

- **Massive baseplate**
for the assembly of the microscope and micromanipulator 11 522 040
- **Extension for DMI 6000 B** 11 521 630
- **Single instrument holder** 11 520 142
- **Dual instrument holder** 11 520 143
- **3 Instrument sleeves** 11 520 145
- **100 glass tubes (diameter 1mm)**
for pipettes 11 520 119

While other micromanipulation accessories such as microtools, pullers, grinders, microforges and anti-vibration tables are not part of the Leica program, they can be supplied by your Leica distributor on request.

Information can also be provided on the adaptation of non-Leica micromanipulation tools for in-vitro fertilization, microinjection, microdissection or patch clamping.

Control Units for Heating Stages and Incubators

A broad range of control units are required for heating stages, objective heaters and incubators. Leica supplies a variety of types depending on the number of components to be heated. For a detailed description and sample applications, please see Leica Microsystem's "Live on Stage" brochure.

TempControl Mini

For objective heater temperature control. Control range 35°C–40°C

- For 115 volts 11 532 310
- For 230 volts 11 531 826

TempControl 37 (1-channel)

For temperature control of a single component. Suitable for objective heaters, heating stages or heating inserts (see pages 14 and 17).

Control range: 3°C above room temperature to max. 60°C

- For 115 volts 11 532 309
- For 230 volts 11 521 721

TempControl 37-2 (2-channel)

For temperature control of two components. Suitable for objective heaters, heating stages, heating inserts or CTI controllers (see pages 14 and 17).

Control range: 3°C above room temperature to max. 60°C

- For 115 volts 11 532 308
- For 230 volts 11 521 719

Heating Unit

Heater to warm air for the incubator ML. Also usable for other incubators when using air rather than CO₂. A TempControl 37-2 unit is always required, however.

3 heating stages

7 ventilation stages

- For 115 volts 11 532 306
- For 230 volts 11 531 833

CTI Controller 3700

CO₂ control unit (concentration and circulation) and temperature control

CO₂ range: 0–7.5% ± 0.1%

Circulation: 5 stages

Temperature stability: ± 0.1°C

RS232 interface

- For 115 volts 11 521 591
- For 230 volts 11 521 588



Fig. 110: TempControl Mini



Fig. 111: TempControl 37



Fig. 112: TempControl 37-2 digital



Fig. 113: Heating unit



Fig. 114: CTI controller 3700

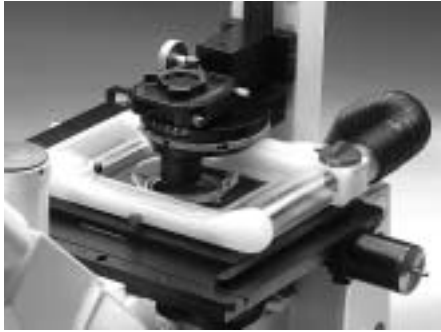

Fig. 115: Incubator S



Fig. 116: CO₂ controller



Fig. 117: POCmini



Fig. 118: POC-R

CO₂ Incubation

A variety of incubators are available depending on the application and features of the inverted microscope.

Incubators are used whenever living cells are to be observed under physiological conditions.

For a detailed description and sample applications, please see Leica Microsystem's "Live on Stage" brochure.

Incubator S

Incubator for heating insert P (11 531 172), for use on regular 3-plate cross-stages and scanning stages.

11 531 171

Incubator S-M

Incubator for the heating inserts M06–M96 (11 531 590, 11 531 823, 11 531 591, 11 531 172), for use on regular 3-plate cross-stages and scanning stages.

11 531 589

Incubator L

Incubator for fixed stages, unheated or heatable, with or without attachable mechanical stage.

11 521 587

Incubator ML

Incubator for the entire microscope

11 521 749

CO₂ Controller

In combination with incubator ML instead of CTI controller

- For 115 volts
- For 230 volts

11 532 305

11 521 733

Further accessories can be found in Leica's application brochure, "Live on Stage" for the following:

- pH value monitoring, e.g. covers for heating inserts, accessories for
- Stage cooling such as thermostats, O₂ monitoring systems
- Evaporation control systems or cell incubation systems (POC chambers)

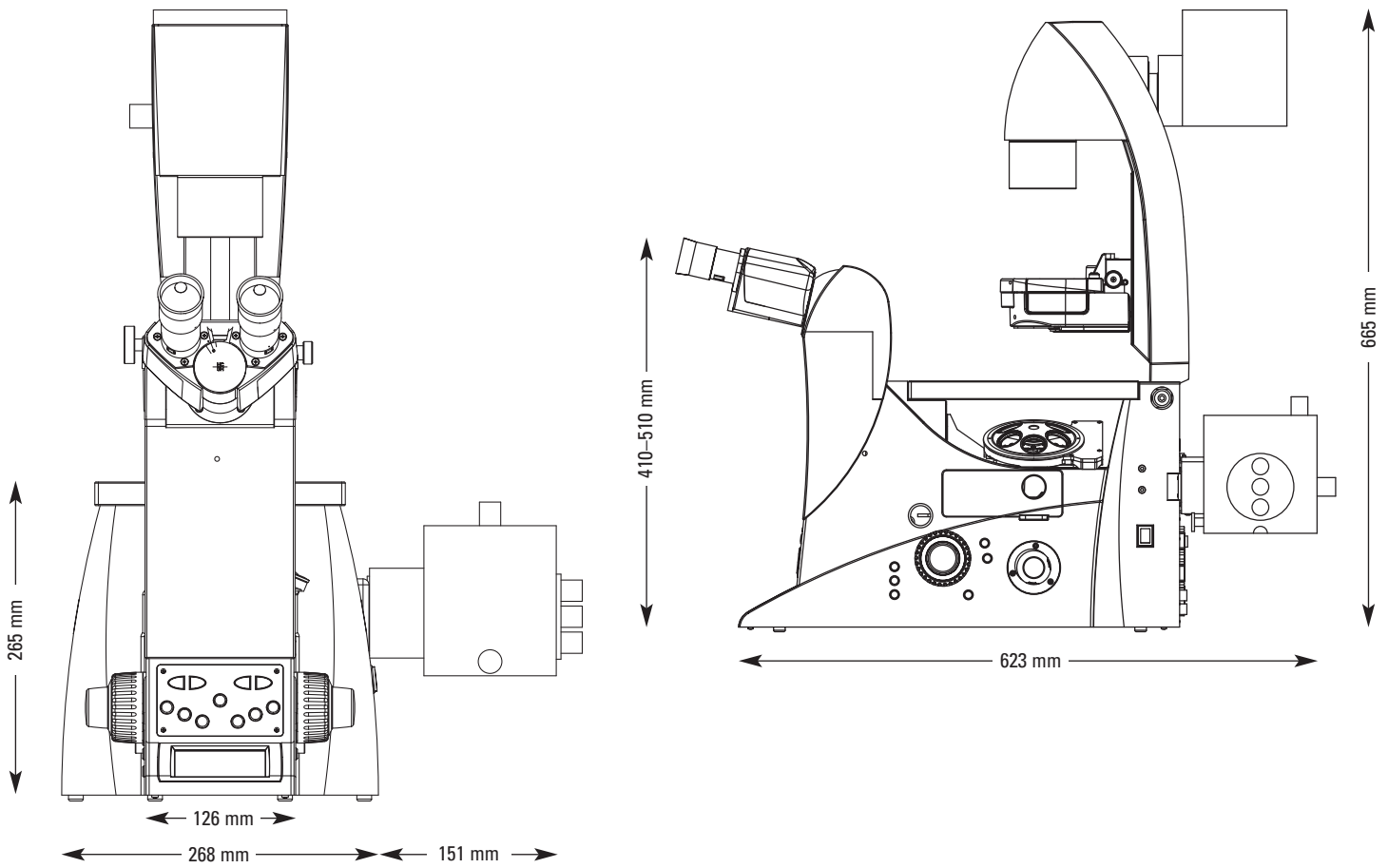

Dimensions and Weights Technical Data

Weights:

Leica DMI 6000 B transmitted light configuration, complete with lamp housing and tube
approximately 21 kg

Leica DMI 6000 B incident/transmitted light equipment, complete with lamp housing and tube
approx. 27 kg

Operating voltage:	90–250V
Frequency:	50/60 Hz
Power consumption:	P max: 180 W
Operating temperature:	10 °C–36 °C
Relative humidity:	0–80% at 30 °C

System Overview

Leica DMI6000 B

TV systems

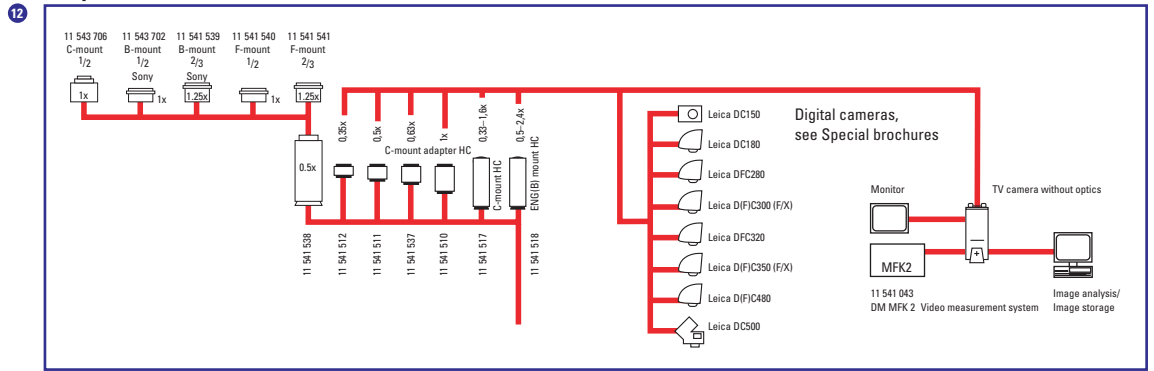

Condensers

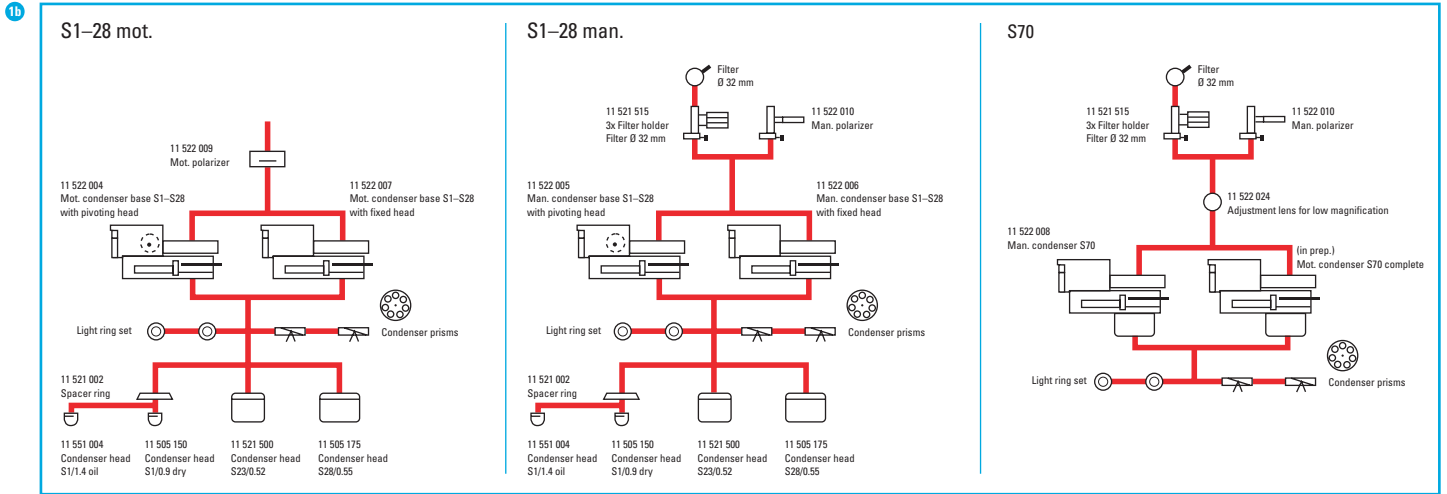

Bino ErgoTubes

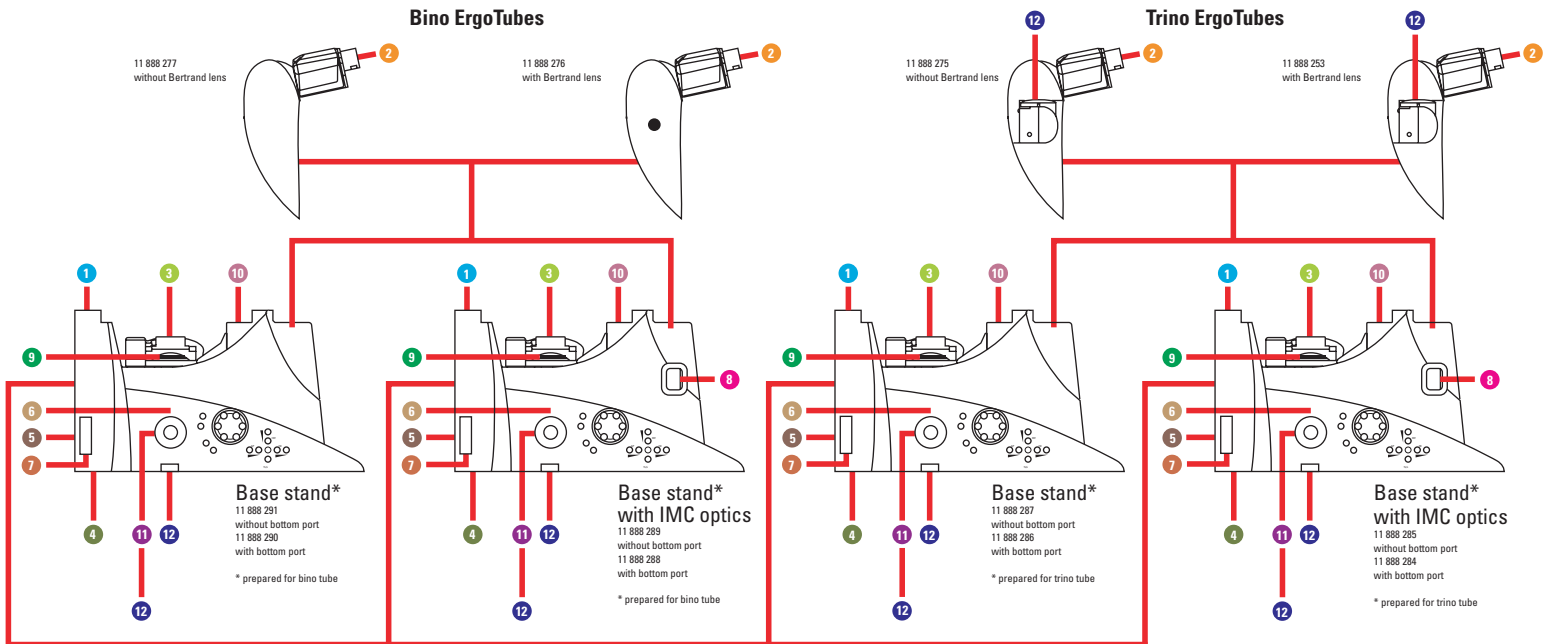

Side ports

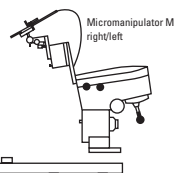
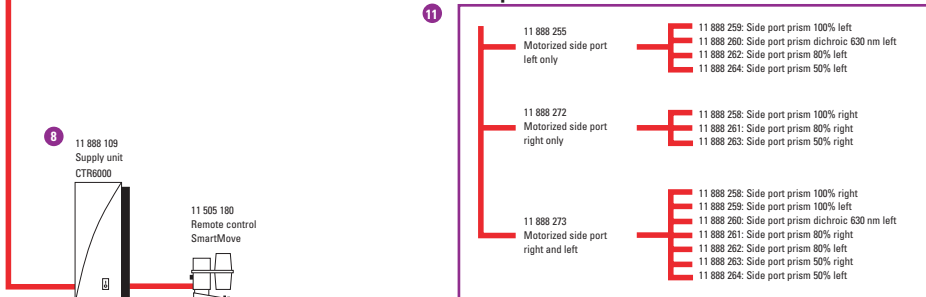

11 522 040 Base plate for Leica DMI6000 B

Transmitted-light axes

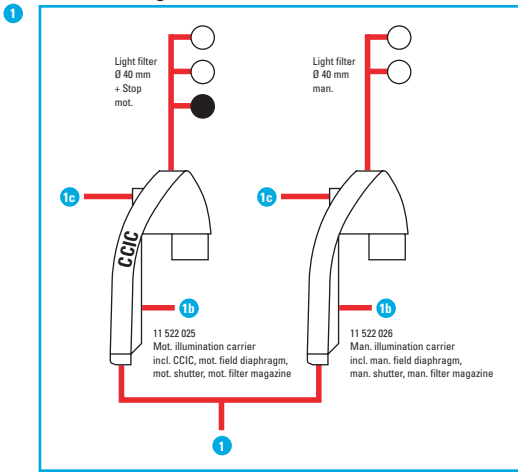

Fluorescence lamp housings

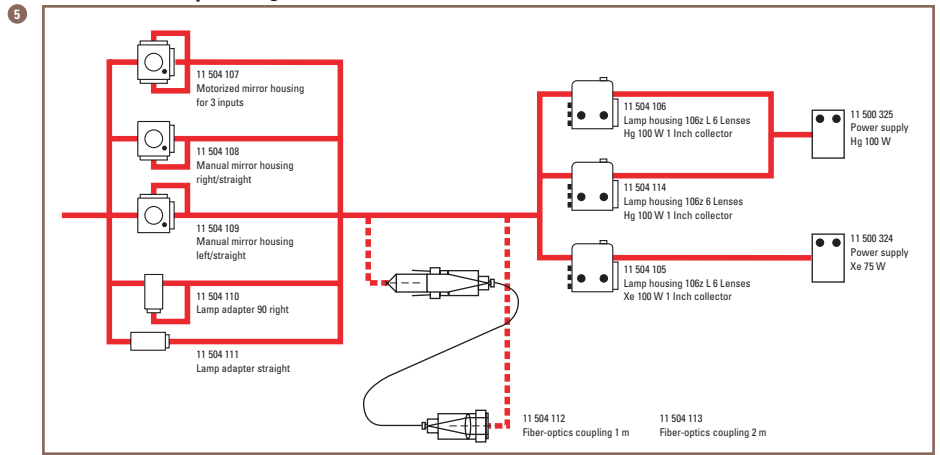

Transmitted-light lamp housings

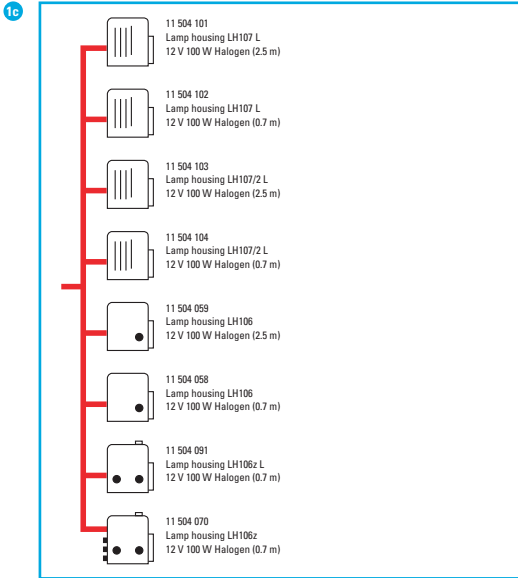

Fluorescence axes and magnification changer

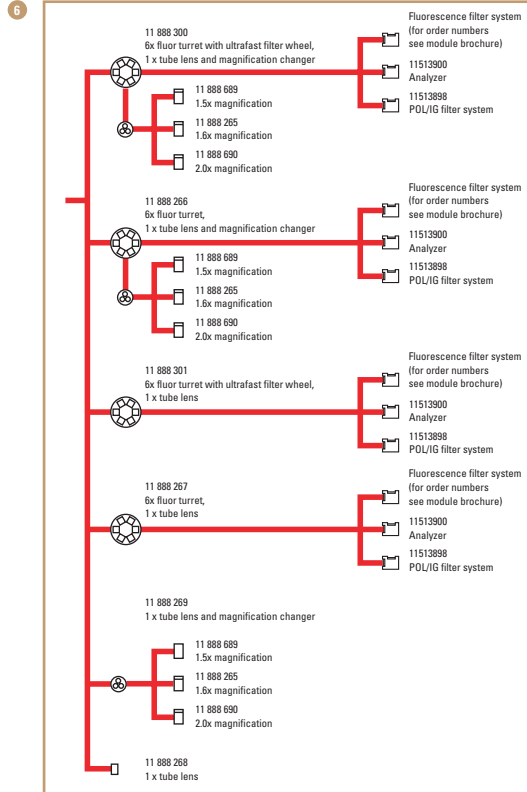

Booster optics



IMC systems

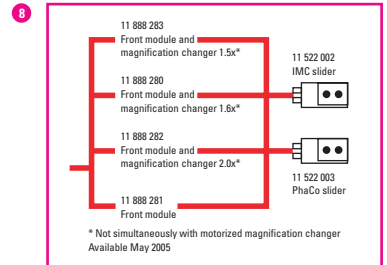

DIC systems

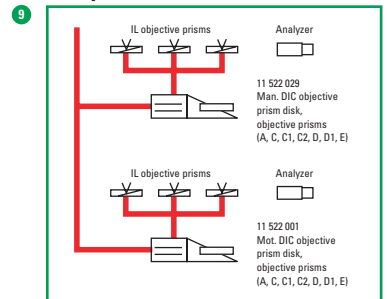

Eyepieces

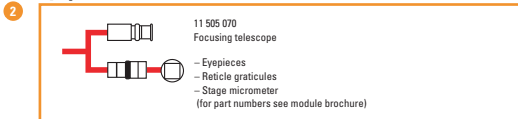

Objectives

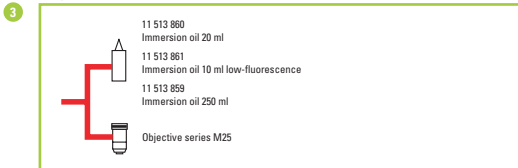

Base plates

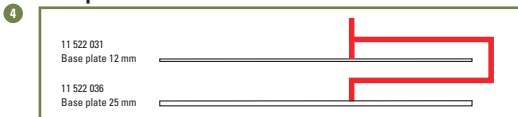

Stages

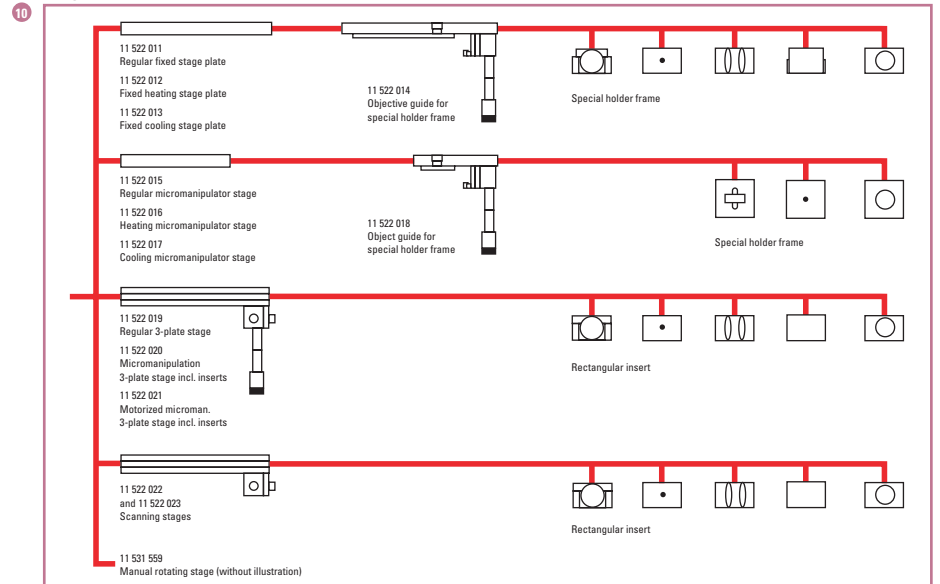

Leica Microsystems – the brand for outstanding products

Leica Microsystems' mission is to be the world's first-choice provider of innovative solutions to our customers' needs for vision, measurement, lithography and analysis of microstructures.

Leica, the leading brand for microscopes and scientific instruments, developed from five brand names, all with a long tradition: Wild, Leitz, Reichert, Jung and Cambridge Instruments. Yet Leica symbolizes innovation as well as tradition.

Leica Microsystems – an international company with a strong network of customer services

Australia:	Gladesville	Tel. +61 2 9879 9700	Fax +61 2 9817 8358
Austria:	Vienna	Tel. +43 1 486 80 50 0	Fax +43 1 486 80 50 30
Canada:	Richmond Hill/Ontario	Tel. +1 905 762 2000	Fax +1 905 762 8937
Denmark:	Herlev	Tel. +45 4454 0101	Fax +45 4454 0111
France:	Rueil-Malmaison	Tel. +33 1 473 285 85	Fax +33 1 473 285 86
Germany:	Bensheim	Tel. +49 6251 136 0	Fax +49 6251 136 155
Italy:	Milan	Tel. +39 0257 486.1	Fax +39 0257 40 3273
Japan:	Tokyo	Tel. +81 3 5435 9600	Fax +81 3 5435 9615
Korea:	Seoul	Tel. +82 2 514 65 43	Fax +82 2 514 65 48
Netherlands:	Rijswijk	Tel. +31 70 4132 100	Fax +31 70 4132 109
People's Rep. of China:	Hong Kong	Tel. +852 2564 6699	Fax +852 2564 4163
Portugal:	Lisbon	Tel. +351 21 388 9112	Fax +351 21 385 4668
Singapore		Tel. +65 6779 7823	Fax +65 6773 0628
Spain:	Barcelona	Tel. +34 93 494 95 30	Fax +34 93 494 95 32
Sweden:	Sollentuna	Tel. +46 8 625 45 45	Fax +46 8 625 45 10
Switzerland:	Glattbrugg	Tel. +41 1 809 34 34	Fax +41 1 809 34 44
United Kingdom:	Milton Keynes	Tel. +44 1908 246 246	Fax +44 1908 609 992
USA:	Bannockburn/Illinois	Tel. +1 847 405 0123	Fax +1 847 405 0164

and representatives of Leica Microsystems
in more than 100 countries.

The companies of the Leica Microsystems Group operate internationally in four business segments, where we rank with the market leaders.

● Microscopy Systems

Our expertise in microscopy is the basis for all our solutions for visualization, measurement and analysis of microstructures in life sciences and industry. With confocal laser technology and image analysis systems, we provide three-dimensional viewing facilities and offer new solutions for cytogenetics, pathology and materials sciences.

● Specimen Preparation

We provide comprehensive systems and services for clinical histo- and cytopathology applications, biomedical research and industrial quality assurance. Our product range includes instruments, systems and consumables for tissue infiltration and embedding, microtomes and cryostats as well as automated stainers and coverslippers.

● Medical Equipment

Innovative technologies in our surgical microscopes offer new therapeutic approaches in microsurgery.

● Semiconductor Equipment

Our automated, leading-edge measurement and inspection systems and our E-beam lithography systems make us the first choice supplier for semiconductor manufacturers all over the world.

 www.light-microscopy.com

LEICA
MICROSYSTEMS