

Motic[®]

BA410 Series
Biological Microscope
Instruction Manual

WWW.MOTIC.COM

MOTIC INCORPORATION LTD.

We are constantly endeavouring to improve our instruments and to adapt them to the requirements of modern research techniques and testing methods. This involves modification to the mechanical structure and optical design of our instruments. Therefore, all descriptions and illustrations in this instruction manual, including all specifications are subject to change without notice.

INFINITY CORRECTED OPTICS

In this optical concept the light beams are parallel after leaving the objective in the direction of the eyepieces. A second optical element, the tube lens (normally located in the eyepiece tube) is used to converge the parallel beams, resulting in an intermediate image. The intermediate image is focussed by the eyepieces, to provide the real image for visual observation.

The implementation of a tube lens gives the opportunity to minimize chromatic aberrations and other “optical defects”. Further, in “Infinity Optics” the distance between the objective and tube lens is not as strictly fixed as in the (historically older) “Finite Optics” of 160mm tube length.

This allows additional optical components to be inserted between the objective and tube head.

Fluorescence attachments, discussion bridges, eye level risers and other options can be added without affecting the image quality.

In general “Infinity Optics” provides flexibility and the opportunity to add additional optional features.

TABLE OF CONTENTS

Section	
I	Nomenclature 4
II	Setting up the instrument 7
	Operating environment 7
III	Assembling the microscope 7
	Verifying Input voltage 7
	1 Mechanical stage 8
	2 Specimen holder 8
	3 Objectives 8
	4 Condenser 9
	5 Eyepiece tube 9
	6 Eyepieces 10
	7 Illumination 10
	8 Filters 11
	9 Power cord 12
IV	Microscopy 12
	1 Coarse and fine focusing 12
	2 Coarse focus torque adjustment 12
	3 Coarse focus quick stop 13
	4 Stage upper limit stop adjustment 13
	5 Beam splitter lever 14
	6 Interpupillary distance adjustment 15
	7 Diopter adjustment 15
	8 Centering the condenser 16
	9 Use of aperture diaphragm 17
	10 Use of field diaphragm 18
	11 Brightness and contrast adjustment 18
V	Photomicrographic procedure 19
VI	Using Oil Immersion Objectives 20
VII	Troubleshooting Table 21
VIII	Care and maintenance 23
IX	Warning label 26

I. Nomenclature

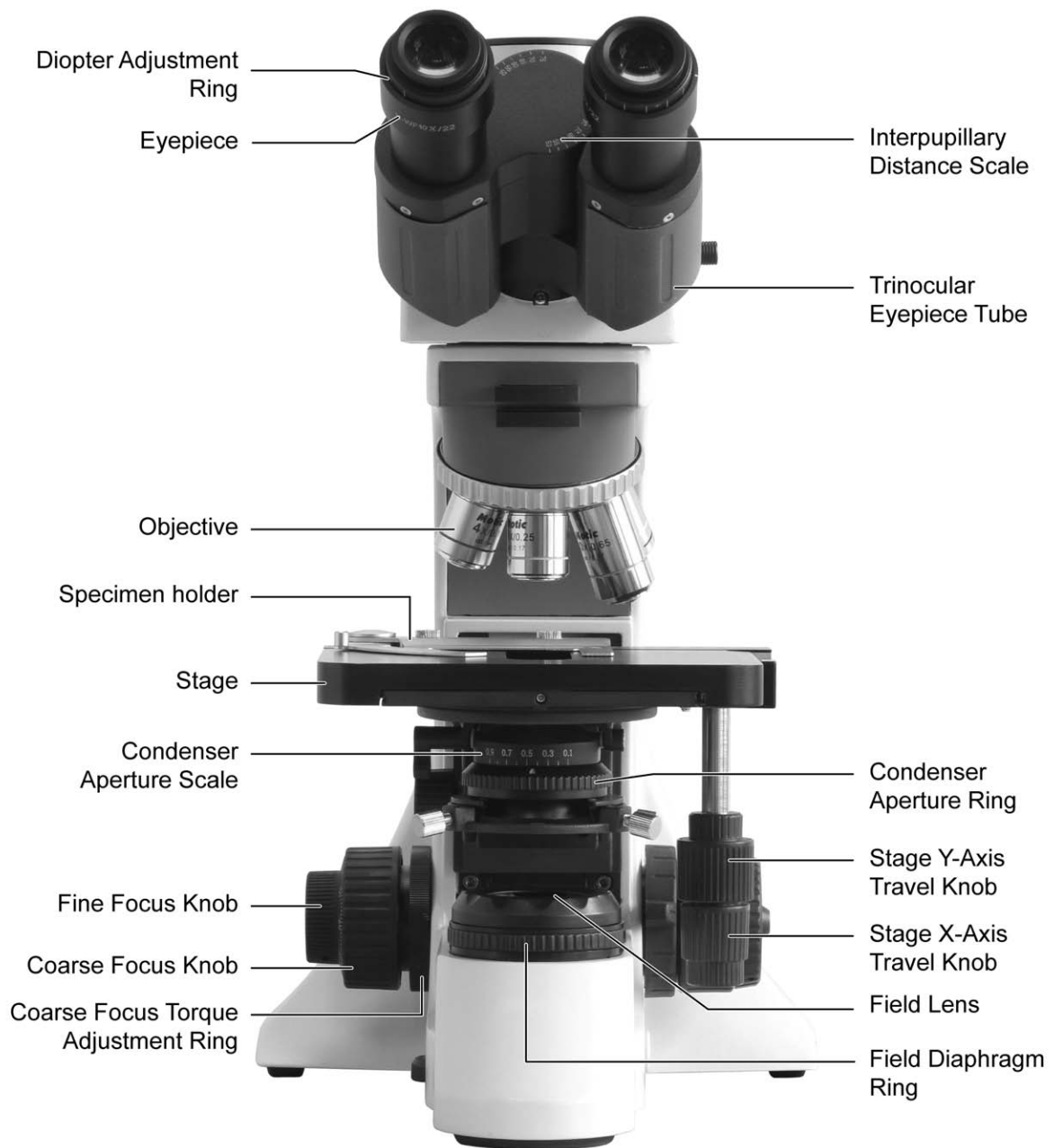

MOTIC BA410 (30W Halogen)

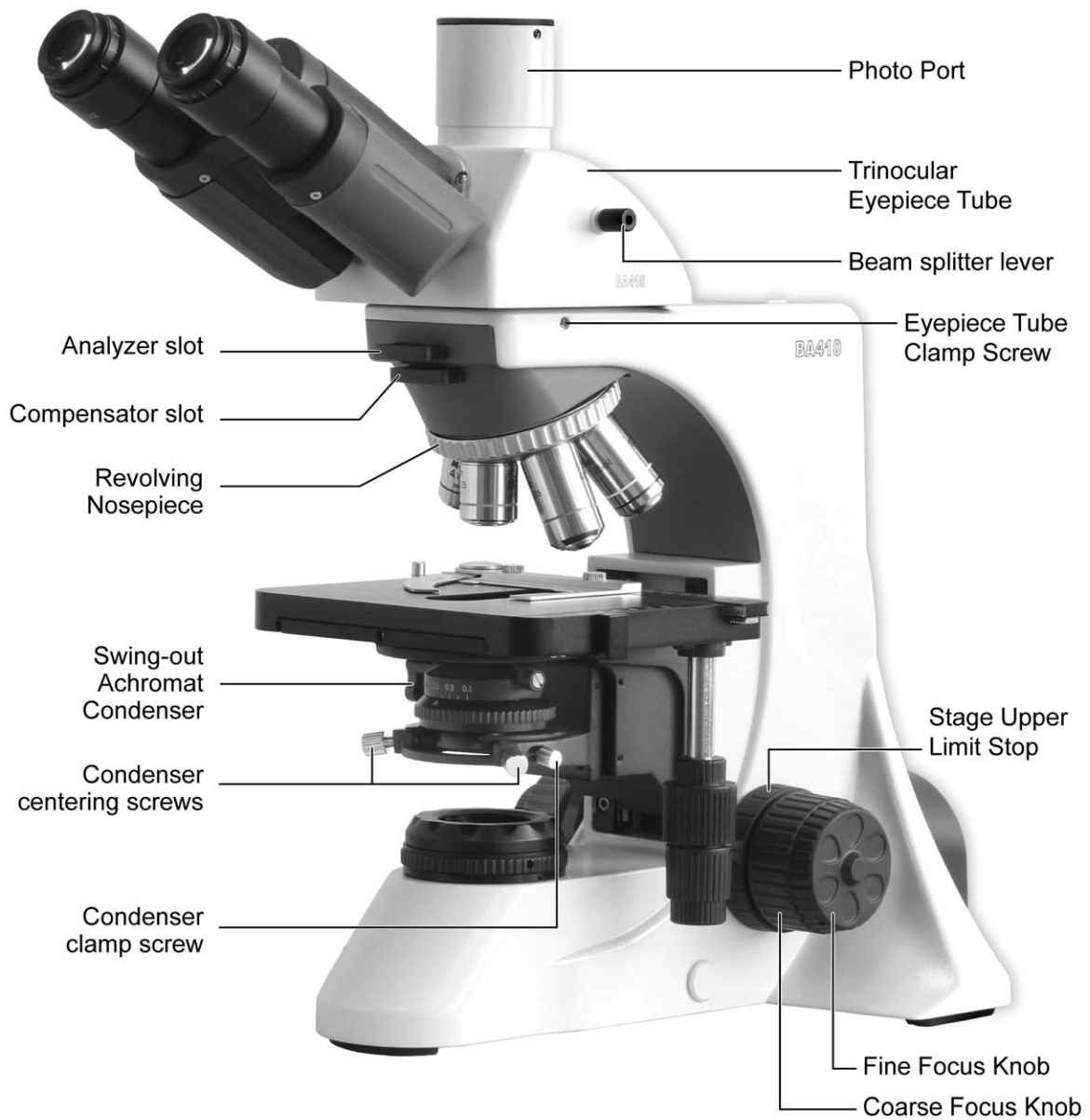

MOTIC BA410 (Trinocular) 30W Halogen

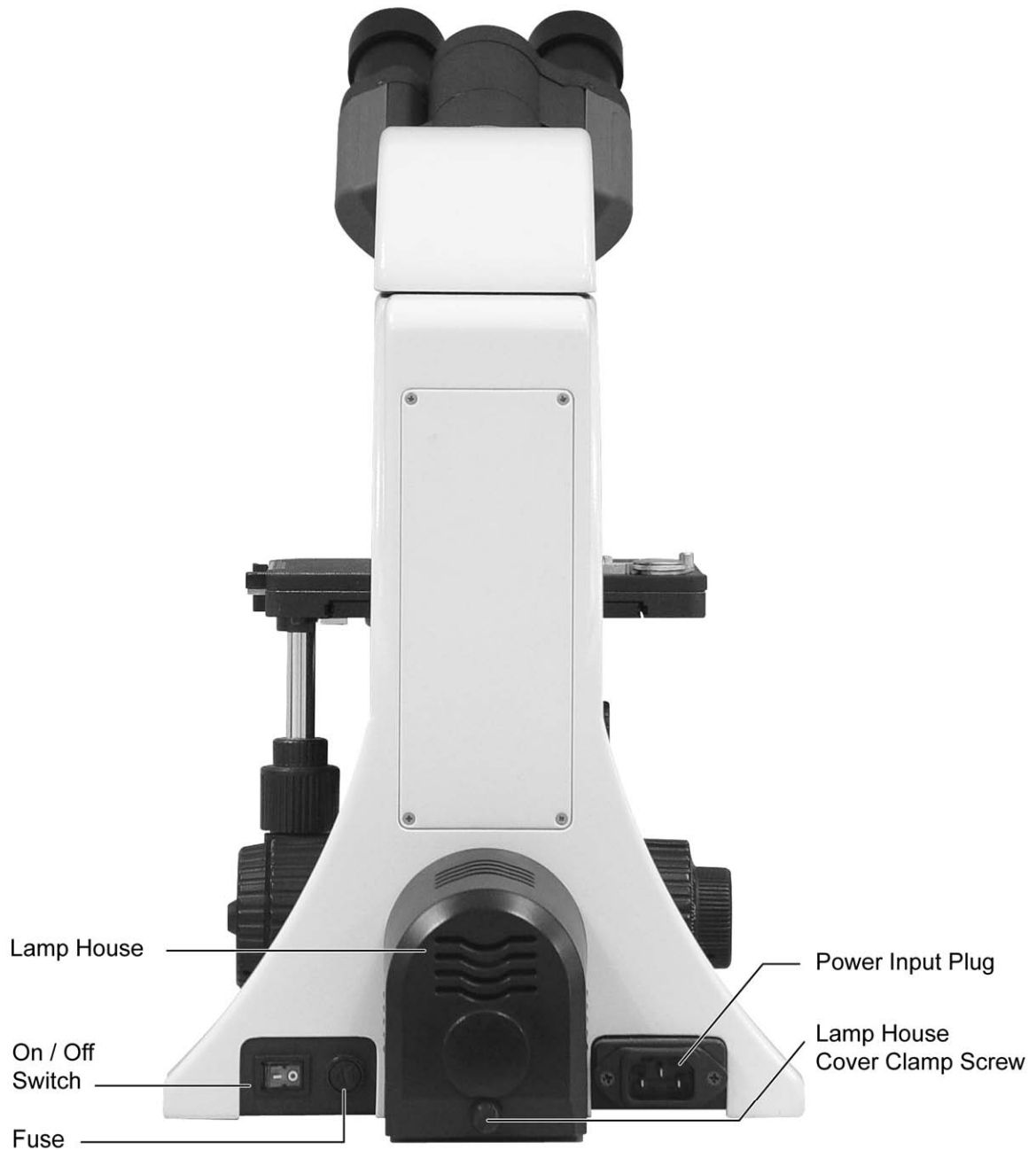

MOTIC BA410 30W Halogen

II. Setting up the instrument

Avoid placing the instrument in locations exposed to direct sunlight, dust, vibration, high temperature, high humidity and where it is difficult to unplug the power supply cord.

Operating environment

- Indoor use
- Altitude: Max 2000 meters
- Ambient temperature: 15°C to 35°C
- Maximum relative humidity: 75% for temperature up to 31°C decreasing linearly to 50% relative humidity at 40°C
- Supply voltage fluctuations: Not to exceed $\pm 10\%$ of the normal voltage
- Pollution degree: 2 (in according with IEC60664)
- Installation / Overvoltage category: 2 (in according with IEC60664)
- Air Pressure of 75kPa to 106kPa
- Avoid frost, dew, percolating water, and rain

III. Assembling the microscope

Verifying Input voltage

- The automatic voltage selection works with a broad range of settings. However, always use a power cord that is rated for the voltage used in your area and that has been approved to meet local safety standards. Using the wrong power cord could cause fire or equipment damage.
- If using an extension cord, use only a power supply cord with a protective earth (PE) wire.
- In order to prevent electric shock, always turn the power supply off before connecting the power cord.

- Electrical Specifications:

30W Halogen Bulb

Input: 90-240V~, 80VA, 50-60Hz

Bulb: 6V  30W Halogen

Fuse: 250V T2.5A (If the original fuse is blown, please replace with specified fuse)

1. Mechanical stage

- Loosen the stage clamp screw; fit the stage into the circular dovetail mount. An orientation notch at the back of the stage has to fit to an orientation pin at the stage carrier. Tighten with the clamp screw facing forward.

- Torque adjustment

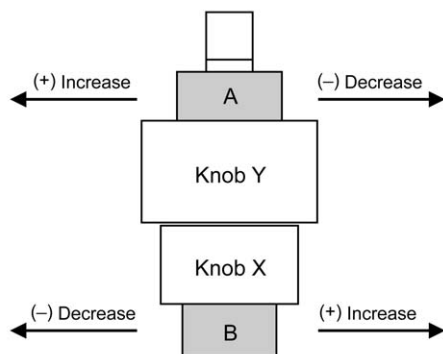

The torque of the y-axis and x-axis travel knobs can be adjusted by torque adjusting knobs.

For y-axis to (+) increase or (-) decrease the torque, turn Knob Y while holding A

For x-axis to (+) increase or (-) decrease the torque, turn Knob X while holding B

2. Specimen holder

- Attach the specimen holder, using the two mounting holes. If the stage is to be used with right-hand controls, attach the specimen holder to the left-hand holes and similarly, with left-hand controls to the right-hand holes.

3. Objectives

- Lower the stage completely. Screw the objectives into the revolving nosepiece so that clockwise rotation of the nosepiece brings the next higher magnification objective into position.

4. Condenser

- Raise the stage by turning the coarse focus knob.
- Completely lower the condenser carrier by turning the condenser focus knob.
- Insert the condenser into the dovetail mount with aperture scale facing forward towards the user. Secure it with the condenser clamp screw.
- Turn the condenser focus knob to raise the condenser as far as it will go.

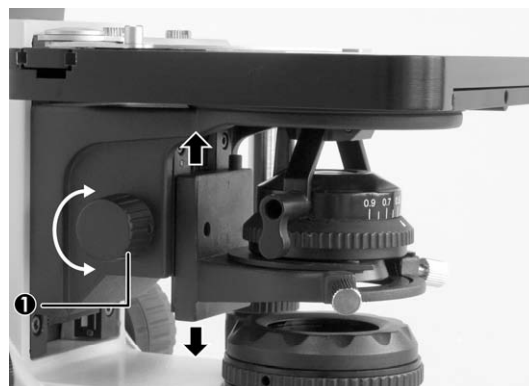

1. Condenser focus knob

5. Eyepiece tube

Loosen the eyepiece tube clamp screw. Insert the round dovetail mount on the eyepiece tube into the round dovetail mount on the microscope arm. Tighten the eyepiece tube clamp screw to secure the eyepiece tube in place.

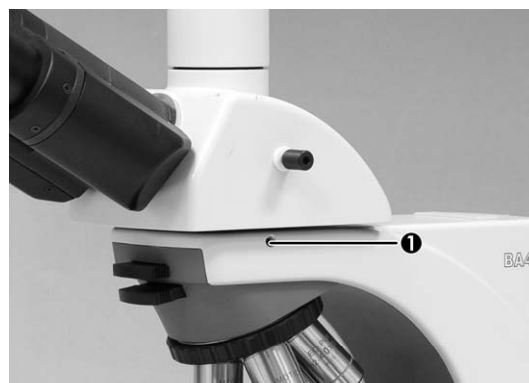

1. Eyepiece Tube Clamp Screw

6. Eyepieces

- Use the same magnification eyepieces for both the eyes.
- Inserting or removing the eyepieces is facilitated by twisting the eyepieces when pushing in or pulling out.

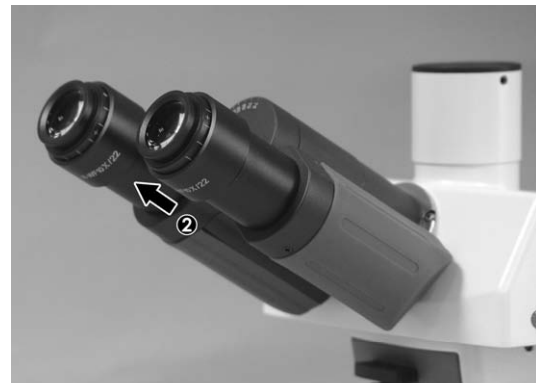

7. Illumination

- The quartz halogen bulb, used as a light source, has higher luminance and color temperature than conventional tungsten bulb. The luminance is approximately four times greater.
- As long as the bulb voltage is kept constant, the halogen bulb maintains the same level of brightness and color temperature regardless of whether it is new or nearing the end of its life.

8. Filters

- Remove the collector cover and place the filter in the filter holder located around the field lens, screw the collector cover, taking care that dust, dirt and fingerprints do not get on the filter and the field lens.

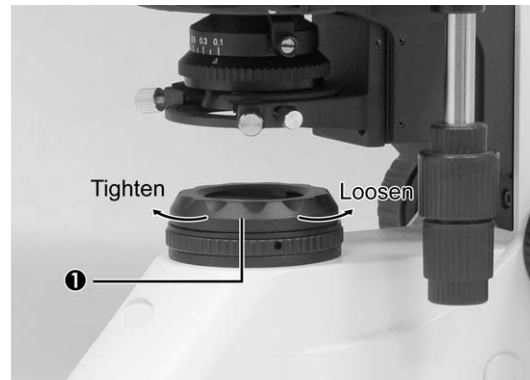

1. Collector Cover

- Filter selection:

Filter	Function
ND2 (T=50%)	For brightness adjustment in photomicrography
Blue filter (colour balance filter)	For routine microscopy and photomicrography
Green interference (546nm)	For phase contrast and contrast adjustment with black and white film
HE (didymium filter)	For colour photomicrography of HE stained specimen with tungsten type film

- Diffuser**

The lamp is pre-centred and pre-focused, saving the inconvenience of having to make these adjustments.

The illuminating system has two plastic disks enclosed in a dustproof covering between the collector lens and field lens, which modify the light passing through them. One disc contains very small diameter lenses of identical curvature aligned to efficiently enlarge the light source image at the condenser aperture. The second disc is a minimum diffusion lemon skin filter that is used to eliminate the haze and inference colours caused by the high uniformity of the first filter.

9. Power cord

Connect the socket of the power cord to the AC inlet on the rear of the base of the microscope. Plug in the other end of the cord to an AC outlet with ground conductor.

IV. Microscopy

1. Coarse and fine focusing

- Focusing is carried out with the coarse and fine focus knobs at the left and right of the microscope stand.
- The direction of vertical movement of the stage corresponds to the turning direction of the focus knobs.
- One rotation of the fine focus knob moves the stage 0.1mm. The graduation on the fine focus knob is 1 micron.

Never attempt either of the following actions, since doing so will damage the focusing mechanism:

- Rotate the left and right knob while holding the other.
- Turning the coarse and fine focus knobs further than their limit.

2. Coarse focus torque adjustment

To increase the torque, turn the torque adjustment ring located behind the left-hand coarse focus knob in the direction indicated by the arrow. To reduce the torque, turn the ring in the direction opposite to that indicated by the arrow.

- 1.) Fine Focus Knob
- 2.) Coarse Focus Knob
- 3.) Coarse Focus Torque Adjustment Ring

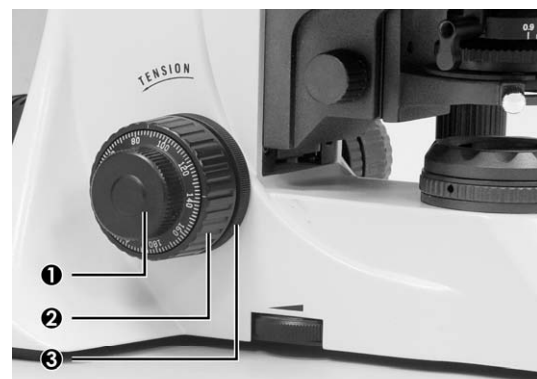

3. Coarse Focus Quick Stop

- The coarse focus height stop serves as a quick accessible possibility for the user to limit the upper focus position in order to prevent a collision of the Objective with the specimen.
- Focus on the specimen using the lowest power objective and the coarse focus knob. Rotate the highest power objective into place. Carefully turn the coarse focus knob raising the specimen until it is just out of focus, but the slide cover slip does not touch the highest power objective.
Simply turn the lever in clockwise direction as shown in the picture below and lock the actual position as upper limit.
- To loosen the upper limit, just turn the lever in the opposite direction

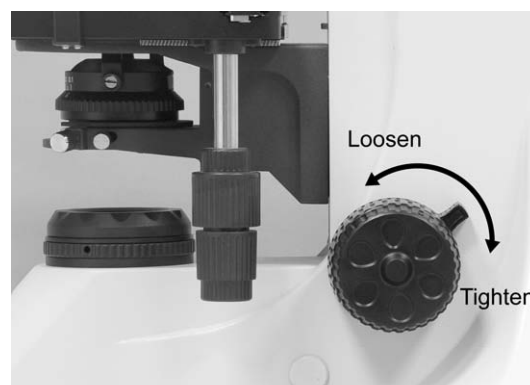

1. Coarse Focus Quick Stop

4. Stage Upper Limit Stop adjustment:

(Upper Stage Limit is preset at the factory; please only adjust if necessary)

- The Stage Upper Limit stop marks the stage position at which the specimen is in focus i.e. by restricting the movement of the coarse focus knob.
- With the specimen in focus, turn the stage upper limit stop knurled ring clockwise until it reaches the stop.
- When the stage upper limit stop is in position, the stage cannot be raised from that position.
However, the fine focus knob can move the stage regardless of the limit but will only lower the stage.
- Lower the stage by using the coarse focus knob anticlockwise

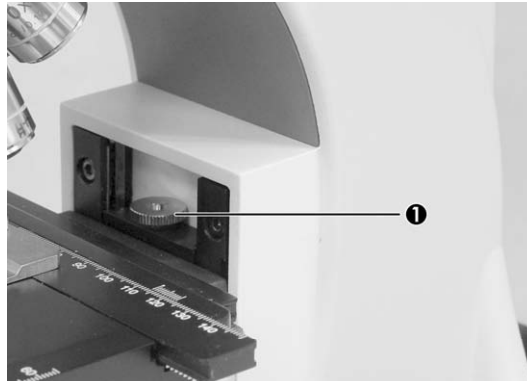

1. Stage Upper Limit Stop

5. Beam Splitter Lever

- When the slider is pushed in, 100% of the light will enter the eyepieces. When pulled out, the light beam will be divided as follows:
- 20:80 (visual: photo; standard tube)
0:100 (visual: photo; tube for low light situations, optional tube)
- The triple position tube (optional) is the most flexible tube by giving 2 photo positions:
- 20:80 (visual: photo; for simultaneous observation by eyepiece and camera)
0:100 (visual: photo; for low light situations, e.g. fluorescence)

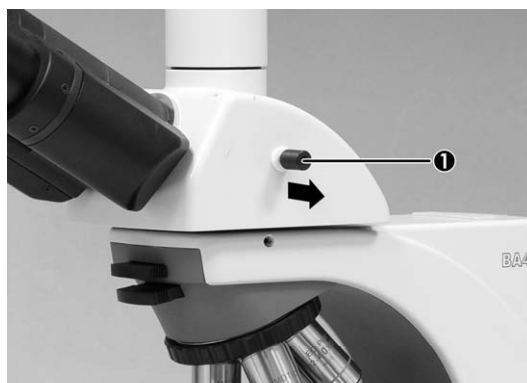

1. Beam Splitter Lever

6. Interpupillary distance adjustment

- Before adjusting the interpupillary distance, bring a specimen into focus using the 10x objective.
- Adjust the interpupillary distance so that both the right and left field of view become one.
- This adjustment will enable the user to observe the specimen with both eyes



- Eyepiece tubes can be swivelled up or down to adjust the viewing height to suit individual preference of comfort viewing. The eye height can be increased by 62mm



7. Diopter adjustment

Every human eye is different, to adjust the Instrument to best performance adjustment can be necessary.

Set the diopter on both eyepieces to the “0” position.

Change to 10x Magnification and focus the image of the specimen with one eye only.

Use the Eye which is most convenient for first focussing.

When the best focus position is reached, close this eye and use the other eye for the following steps.

Correct the focus for the second eye by using only the Diopter Ring, do not use the coarse / fine focusing knob!

Change to a higher magnification to verify the result and if necessary repeat the procedure to match the sharpness for higher magnification.

Keep this final diopter position for all magnification / lenses. The diopter position for each **user** can be recorded from the scale, so it can easily be reset.

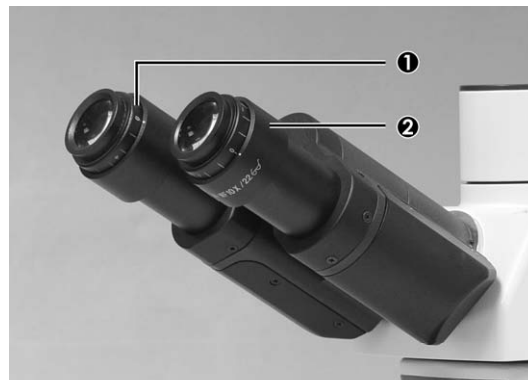

1. Diopter scale 2. Diopter adjustment ring

8. Centering the condenser

- Fully open the field of view diaphragm and condenser aperture diaphragm.
- Set the specimen on the stage with the cover glass facing up.
- Bring the specimen image into focus, using the 10X objective.
- Turn the condenser focus knob to bring the field diaphragm image into focus on the specimen plane.
- Adjust the condenser by using the condenser centering screws.
- Adjust the field diaphragm so that it is just outside the field of view for each magnification change.

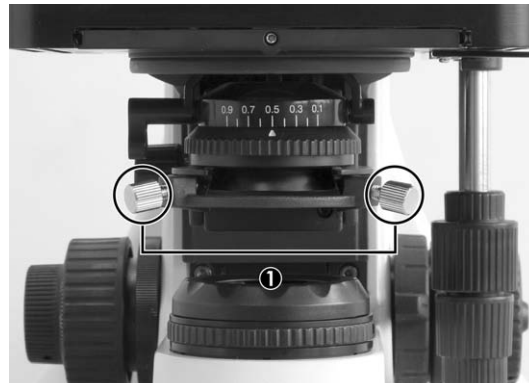

1. Condenser Centering Screws

9. Use of aperture diaphragm

- The condenser aperture diaphragm is provided for adjusting the numerical aperture (N.A.) of the illuminating system of the microscope, it decides the resolution of the image, contrast, depth of focus and brightness.
- Stopping down will lower the resolution and brightness but increase the contrast and depth of focus.
- An image with appropriate contrast in most cases can be obtained with an aperture diaphragm closed down to 2/3 of the maximum value.
- To adjust the aperture diaphragm:
 - adjust the condenser aperture diaphragm ring referring to the condenser aperture scale, or
 - by observing the diaphragm image visible on the exit pupil inside the eyepiece tube, or
 - by using a centering telescope after removing one of the eyepieces and focusing on the aperture diaphragm.
- When swinging-out the top lens of the condenser for low magnification objectives, open the condenser aperture diaphragm completely.

10. Use of field diaphragm

- The field diaphragm determines the illuminated area on the specimen. For normal observation, the diaphragm is set slightly larger than the field of view. If the illuminated area is set much larger than the field of view extraneous light will enter the field of view. This will create a flare in the image and lower the contrast.
- In case the image of the field diaphragm cannot be centered due to thick glass slides or chambers with thick bottoms, a long working distance condenser is available for correct Koehler illumination.
- The diaphragm does not have any effect when the condenser top lens is swung out of the optical path. Fully open the field diaphragm, as the N.A. of the illuminating system will be reduced if the diaphragm is excessively stopped down.

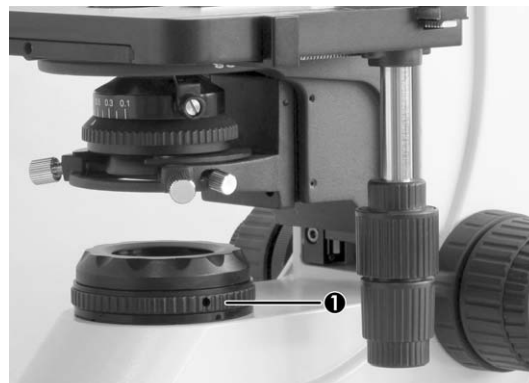

1. Field Diaphragm Ring

11. Brightness and contrast adjustment

- Neutral density filters are used for brightness adjustment in routine microscopy and photomicrography.
- For phase contrast and contrast adjustment with black and white film, a Green interference filter (546nm) is recommended.
- An HE (didymium) filter for colour photomicrography, Haematoxylin, Eosin (HE) or Fuchsin stained specimen with tungsten type film is available.

V. Photomicrographic procedure

- To ensure vibration free operation, set the microscope on a sturdy vibration free table or a bench with a vibration proof device.
- Pull the optical path selection lever of the trinocular eyepiece tube all of the way out to the limit.
- To ensure optimal illumination, check the position and centring of the lamp and position of the condenser.
- Select a blue filter for routine application. An additional colour-compensating filter can also be used depending on the colour rendition.
- Adjusting the field diaphragm is important for the purpose of limiting extraneous light that may cause flare and lower the contrast. Stop down the diaphragm to achieve an illuminated area slightly larger than that of the field of view.
- A change in depth of focus, contrast and resolution of the image is attainable with an aperture setting of $2/3$ of the maximum diaphragm diameter.
Fine setting of the condenser aperture varies with the individual sample.
- For photomicrographic procedures, refer to the manual of the specific camera being used.

VI. Using an oil immersion objective

- Oil immersion objectives are labelled with the additional engraving “Oil” and are to be immersed in oil between the specimen and the front of the objective.
- The immersion oil supplied by Motic is synthetic, non-fluorescing and non-resining oil, with a refractive index of 1.515
- Normally, cover glass must be used with oil immersion objectives with a few exceptions. Deviations from thickness are not important as a layer of immersion oil acts as compensation above the cover glass.
- The small bottle of oil supplied with every immersion objective facilitates application of the oil to the cover slip.
- Remove any air bubbles in the nozzle of the oil container before use.
- Immersion oil must be used sparingly. After the examination, the oil should be wiped off the objective with a lens cleaning tissue and the residual film removed with soft cloth moistened with petroleum benzene or absolute alcohol.
- Locate the field of interest with a lower magnification objective. Swing the objective out of the light path, and add one drop of immersion oil over the site of the specimen. Swing in the oil immersion objective. There should be a small column of oil from the cover slip to the objective lens. Use the fine focus to make the image sharp.
- Freedom from air bubbles must be ensured. To check for air bubbles, remove an eyepiece, fully open the field and aperture diaphragms, and look at the exit pupil of the objective within the eyepiece tube. Air bubbles are recognized by a surrounding black ring. Bubbles may often be dislodged by moving the slide to and fro or by slightly rocking the revolving nosepiece back and forth. If not successful in clearing the bubbles then the oil must be wiped off and replaced with a fresh drop.

VII. Troubleshooting Table

As you use your microscope, you may occasionally experience a problem. The troubleshooting table below contains the majority of frequently encountered problems and the possible causes.

Problem	Possible Cause
Vignetting or uneven brightness in the field of view	Bulb not installed properly
	Condenser not mounted correctly
	Condenser is not centred
	Condenser is set too low
	Condenser top lens not fully swung in/out
	Field diaphragm closed too far
	Aperture diaphragm closed too far
	Improper condenser/objective combination
	Revolving nosepiece not clicked into position
	Trinocular eyepiece tube optical path selector lever in intermediate position
Dust or dirt in the field of view	Aperture diaphragm closed too far
	Condenser is set too low
	Dust or dirt on specimen surface
	Dust or dirt on field lens, filter, condenser or eyepiece
Poor image (low contrast or resolution)	Condenser is set too low
	Aperture diaphragm closed too far
	No cover glass
	Too thick or thin cover glass
	Immersion oil not used with oil immersion lens
	Air bubbles in immersion oil
	Specified immersion oil not used
	Immersion oil on dry objective
	Greasy residue on eyelens
Incorrect illumination	

Poor image (low contrast or resolution)	Dried stain or oil on objective lens. Lens must be removed from the microscope and examined with a magnifier (an inverted eyepiece can be used) to check for dirt
Uneven focus	Stage installed on inclined plane
	Specimen holder not fixed securely on stage
	Specimen not secured in position
	Magnification or field of view of left and right eyepieces differ
	Diopter adjustment not made

Electrical

Bulb does not light	Power supply not plugged in
	Bulb not installed
	Bulb burnt out
Inadequate brightness	Specified bulb not being used
Bulb blows out	Specified bulb not being used
Bulb flickers	Connectors are not securely connected
	Bulb near end of service life

VIII. Care and maintenance

A. Do not disassemble

1. Disassembly may significantly affect the performance of the instrument, and may result in electric shock or injury and will void the terms of the warranty.
2. Never attempt to dismantle any parts other than described in this manual. If you notice any malfunction, contact your nearest Motic representative.

B. Cleaning the Microscope

1. Lenses and filters

- To clean lens surfaces or filters, first remove dust using an air blower. If dust still persists, use a soft/clean brush or gauze.
- A soft gauze or lens tissue lightly moistened with the mixture of alcohol and ether (ratio : alcohol : 3 and ether: 7) should be used to remove grease or fingerprints.
- Use only a mixture of alcohol and ether (ratio : alcohol : 3 and ether: 7) to remove immersion oil from objective lenses.
- Because the mixture of alcohol and ether (ratio : alcohol : 3 and ether: 7) is highly flammable, be careful handling around open flame.
- Do not use same area of gauze or lens tissue to wipe more than once.

2. Cleaning of painted or plastic components

- Do not use organic solvents (thinners, alcohol, ether, etc.). Doing so could result in discolouration or in the peeling of paint.
- For stubborn dirt, moisten a piece of gauze with diluted detergent and wipe clean.
- For plastic components, only moisten a piece of gauze with water and wipe clean.

C. Disinfecting the Microscope

- Follow the standard procedures for your laboratory.

D. When not in use

- When not in use, cover the instrument with vinyl dust cover and store in a place low in humidity where mould is not likely to form.
- Store the objectives, eyepieces and filters in a container or desiccator with drying agent.
- Proper handling of the microscope will ensure years of trouble free service.
- If repair becomes necessary, please contact your Motic agency or our Technical Service direct.

Note:

- If equipment is used in a manner not specified by the manufacturer, the warranty may be void.
- To avoid getting wet, do not use the microscope near water.

E. Bulb Replacement (30W Halogen bulb)



The bulb and the lamphouse become very hot during and after a period of operation.

Risk of burn – Do not touch the bulb during or immediately after a period of operation.

Make sure the bulb has cooled sufficiently before attempting to replace the lamp.

30W Halogen



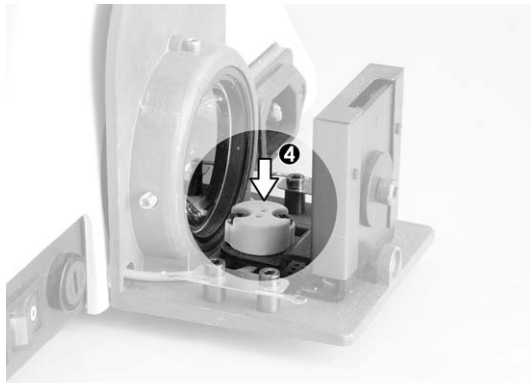



- The applicable halogen bulbs are the 6V 30W HAL high-intensity bulb
- In order to prevent electric shock always turn the power switch off and unplug the power cord before installing or replacing the lamp.
- Loosen the lamp housing cover clamp screw using a coin and remove the cover.
- When installing the bulb, do not touch the glass surface of the bulb with bare fingers. Doing so will cause fingerprints, grease, etc., to burn onto the bulb surface, reducing the illumination provided by the bulb. If the surface is contaminated, wipe it clean using lens tissue.
- Firmly insert the bulb into the socket pinholes until it reaches the limit. Be careful not to tilt the bulb when mounting.



- Close the cover and secure with it with lamp housing cover clamp screw.

IX. Warning labels

The following warning labels (or symbols) are found on the microscope, study the meaning of the warning labels (or symbols) and always use the equipment in the safest possible manner.

Warning Label / Symbol	Explanation
	Indicates that the surface becomes hot, and should not be touched with bare hands.
	Indicates that the main switch is ON.
	Indicates that the main switch is OFF.
	Indicates alternating current.
	Indicates direct current.
	CAUTION! Risk of danger. Please consult documentation in all cases where this symbol is used.

The bulb and the lamphouse become very hot during and after a period of operation.
Risk of burn – Do not touch the bulb during or immediately after a period of operation.
Make sure the bulb has cooled sufficiently before attempting to replace the bulb.

Don't pick the microscope up from the bottom during equipment operation.

Proper handling of the microscope will ensure years of trouble free service.
If repair become necessary, please contact your Motic agency or our Technical Service directly.

Motic[®]

NO.: 1300901106661

Motic Incorporation Ltd. (Hong Kong)

Rm 2907-8, Windsor House, 311 Gloucester Road, Causeway Bay, Hong Kong Tel: 852-2837 0888 Fax: 852-2882 2792

Motic Instruments Inc. (Canada)

130-4611 Viking Way, Richmond, B.C., V6V 2K9 Canada Tel: 1-877-977 4717 Fax: 1-604-303 9043

Motic Deutschland GmbH (Germany)

Christian-Kremp-Strasse 11 D-35578 Wetzlar, Germany Tel: 49-6441-210 010 Fax: 49-6441-210 0122

Motic Spain, S.L. (Spain)

Polígono Industrial Les Corts, Camí del Mig, 112 08349 Cabrera de Mar, Barcelona Spain Tel: 34-93-756 6286 Fax: 34-93-756 6287

Website: <http://www.motic.com>

E-mail: digital.info@motic.com

Motic China Group., Ltd. (China)

Motic Building, Torch Hi-Tech Industrial, Development Zone, Xiamen P.R.C. Tel: 86-0592-562 7866 Fax: 86-0592-562 7855

©2007-2008 Motic China Group Co., Ltd. All rights reserved. Motic is a registered trademark and service mark of Motic China Group Co., Ltd. Microsoft Windows logo is a registered trademark of Microsoft Corporation. All other trademarks are the property of their respective owners.

Design Change: The manufacturer reserves the right to make changes in instrument design in accordance with scientific and mechanical progress, without notice and without obligation.