



Leica FluoCombi III™

User manual

Dear User,

Thank you for your confidence in our products. We trust you will enjoy them and we wish you great success with the high-quality and high-performance products from Leica Microsystems.

In developing our instruments, we place great value on simple, self-explanatory operation. Nevertheless, please take the time to read the operating instructions so that you know the advantages and possibilities offered by your stereomicroscope and can use them most efficiently. Should you ever have any questions, please consult your local Leica representative. We are gladly at your service. Customer service is a big thing with us. Not only before the sale, but afterwards as well. You will find the address of your nearest local representative, as well as valuable information about Leica Microsystems products and services, from Leica Microsystems on our web site at www.leica-microsystems.com.

Leica Microsystems (Switzerland) Ltd.
Stereo & Macroscopic Systems
www.stereomicroscopy.com

Overviews



Fig. 1 Leica Fluocombi III™, 5× planapo HR objective rotated into the beam path

Operating and function elements

- 1 Fine focusing with mount thread for a 5× or 20× HR objective (requires an adapter)
- 2 Clamping screw for locking the fine focusing
- 3 Mechanism for parcentric swinging to the stereo or micro mode
- 4 Slot for filter slide for dichroic mirror of your choice
- 5 Mount for UV protection screen



Fig. 2 Leica Fluocombi III™, 1× planapo objective rotated into the beam path

- 6** Clamping screw for fastening the UV protection screen
- 7** Clamping screw for locking the UV protection screen in the desired tilt position
- 8** Clamping screw for fastening the optics carrier in the microscope carrier of the Fluocombi III™
- 9** Clamping screw for fastening the focusing stop

Contents

Page

Overviews	
Operating and function elements	3, 4
1. General notes	6
1.1 The user manual	6
1.1.1 Diagrams	6
1.2 Description	6
2. Assembly	
2.1 Expansion diagram	7
2.2 Standard delivery	8
2.2.1 Additional components	8
2.3 Assembly sequence	9
2.4 Column with focusing drive and base of stand	10
2.5 Focusing stop	10
2.6 Transport anchorage	11
2.7 FluoCombi III™ and focusing drive	11
2.8 Optics carrier	12
2.9 Objectives	13
2.10 UV protection screen	14
2.11 Dichroic mirrors	14
2.12 Illumination	14
3. Operation	
3.1 Parfocality	15
3.2 Magnification	17
4. Appendix	
4.1 Weights	18
4.2 Dimensions	19
4.3 Optical data	22
4.4 Technical data	24

1. General notes

1.1 The user manual

Leica FluoCombi III™ is an accessory for the Leica MZ16 F, MZ16 FA fluorescence stereomicroscopes. Together with your Leica FluoCombi III™, you receive an interactive CD-ROM with the user manual for all products from Leica Microsystems (Switzerland) in the current EU languages. User manuals and updates are also available for you to download and print from our web site at www.stereomicroscopy.com. The following user manuals are important for your Leica FluoCombi III™:

- M2-166-2 Leica FluoCombi III™: It describes the specific functions of the FluoCombi III™
- M2-160-4 for MZ16 FA and M2-160-5 for MZ16 F describe the functions of the motorized and the manual version
- M2-216-1 describes the lamp housing and its functions
- M2-105-0 Leica M Stereomicroscopes: It contains all the detailed information about the use of the stereomicroscope, the optical data with stereo objectives, and the safety and care instructions
- M1-267-1 Leica motor focus system: describes the motorized focusing



Read the user manuals listed above before the startup procedure. In particular, please follow the safety instructions.

To maintain the unit in its original condition and to ensure safe operation, the user must follow the instructions and warnings contained in these user manuals.

1.1.1 Diagrams

Pages 3 and 4 contain figures showing the Leica FluoCombi III™ with the function elements. Numbers in parentheses within the descriptions refer to the number of the figure and the items in the figure.

Example (1.4): Figure 1 is located on page 3, and the item 4 is the insert for dichroic mirrors.

1.2 Description

Leica FluoCombi III™ is an accessory for the Leica MZ16 F, MZ16 FA fluorescence stereomicroscopes and allows for quickly switching between a stereo objective and an HR (High Resolution) micro objective. In stereo mode, the 1× plan and planapo objectives offer generous viewing fields, large working distances and an excellent depth of field for manipulating and dissecting. Micro mode allows for exactly identifying the finest fluorescent features at a microscopic resolution of 1500 pairs of lines/mm. The zoom is also effective in micro mode so that the magnification measures 460× using the 5× HR objective. Using 16× eyepieces results in a maximum magnification of 736×. The comfortable binocular observation is ensured in stereo and micro mode.

MZ16 F and MZ16 FA are high-performance stereomicroscopes for fluorescence applications. The patented, separate TripleBeam™ light path for fluorescence illumination and the patented FLUOIII™ filter system provide highest-quality fluorescence images. Every existing instrument can be fitted with the Leica FluoCombi III™ in a few simple steps.

2. Assembly

2.1 Expansion diagram

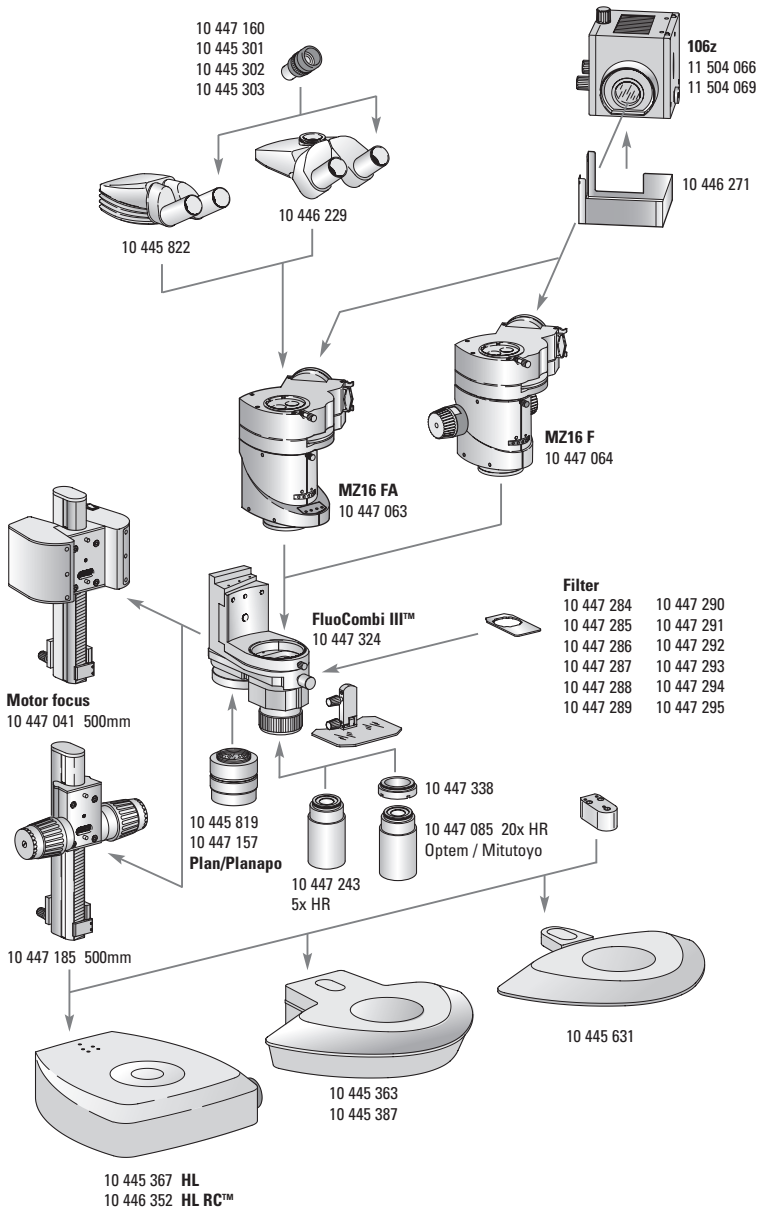

2.2 Leica FluoCombi III™ standard delivery

- Leica FluoCombi III™ with microscope carrier (Fig. 3) for the MZ16 F and MZ16 FA optics carrier, mechanism for swinging into the stereo or micro mode, fine focusing with mount thread for an HR objective and for a 1× plan or planapo objective
- UV protection screen (7.11)
- Focusing stop with stops (7.3)
- Column adapter (7.2a)

2.2.1 Additional components

- HR planapo objective 5×/0.5 LWD (Fig. 4), FAA 19mm or
- Adapter (5.1) for Mitutoyo/Optem objectives and screw-in adapter (5.2) as well as the corresponding objective
- Fluorescence stereomicroscope (7.5) with third TripleBeam™ beam path, FLUOIII™ filter system, rapid filter changer and Leica lamp housing for mercury high-pressure lamps as well as binocular tube, eyepieces, stand and focusing drive
- 1× Plan or planapo objective (7.9)
- Dichroic mirror of your choice (Fig. 6)

Assembly and setup of Leica MZ16 F, MZ16 FA fluorescence stereomicroscope and the fluorescence illumination are described in the respective operating instructions (see p. 6).

Binocular tube, eyepieces, stands, mercury vapor lamp, etc. are described in the operating instructions M2-105-0, M2-160-5, M2-160-4, M2-216-1.



Fig. 3 Leica FluoCombi III™



Fig. 4 HR planapo objective 5×/0.5 LWD



Fig. 5 Adapter (1) for Mitutoyo/Optem objectives and screw-in adapter (2)

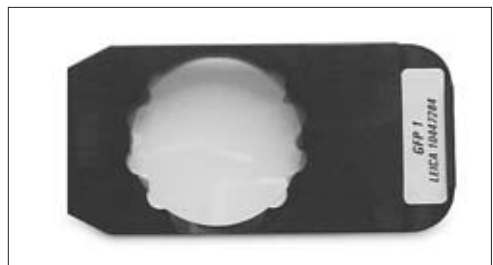

Fig. 6 Dichroic mirror

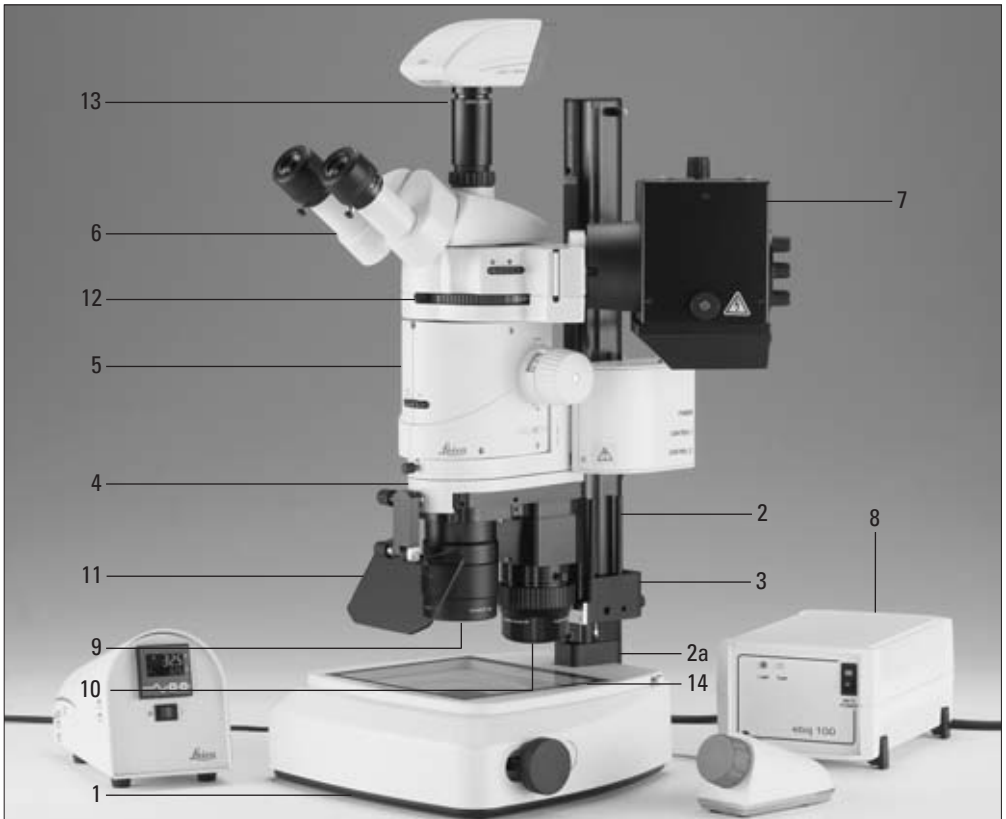

Fig. 7 Leica MZ16 F with Leica FluoCombi III™

2.3 Assembly sequence

- | | |
|---|---|
| <ul style="list-style-type: none"> 1 Base of stand 2 Focusing drive with column (manual or motorized) and column adapter (2a) 3 Focusing stop 4 Leica FluoCombi III™ 5 Optics carrier 6 Binocular or video/photo tube and eyepieces 7 Lamp housing with high-pressure lamp and stray-light protection 8 Supply unit | <ul style="list-style-type: none"> 9 Plan or planapo objective 1× 10 HR planapo objective 5× (or adapter and Mitutoyo/Optem objective) 11 UV protection screen 12 Filter sets upon demand in the filter changer and analogous with a dichroic filter in the FluoCombi III™ 13 Photo equipment (if available) 14 Gliding stage or thermal stage (if available) |
|---|---|

2.4 Column with focusing drive → base of stand

First, attach the column adapter between stand column and base. It is used to ensure that the center of the objective lies exactly over the center of the stage.

- ▶ Fasten the column adapter (8.1) with the 3 hexagon-head screws on the column.
- ▶ Fasten the column with the column adapter on the stand base according to the operating instructions M2-105-0.

2.5 Focusing stop



The focusing stop is used for safety purposes and must always be correctly set with respect to the micro objective.

- ▶ Fasten the focusing stop (8.2) to the column with the clamping screw (8.3).



Set the focusing stop at a height so that the micro objective can never hit the stand or table surface or the object during focusing and swinging. Working distance 5× HR objective: 19mm, 20× HR objective 13mm.



With a correctly set focusing stop, the two stops prevent focusing too low, either manually or motorized.

If the focusing stop is set too low

- the objective could be damaged.
- the object could be crushed or damaged.
- if the lowest focus position is approached too quickly using the motor focus, the fingers of the operator could be pinched between objective and object.

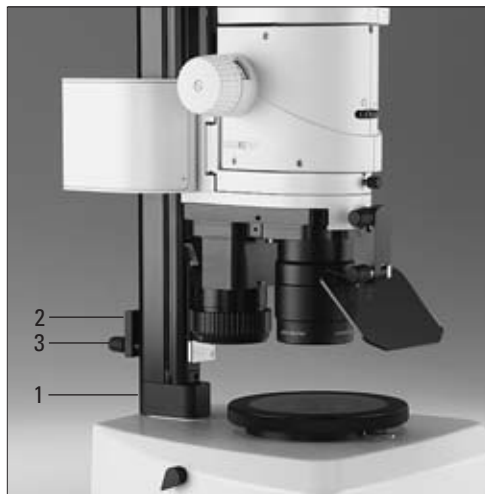

Fig. 8

- 1 Column adapter
- 2 Focusing stop
- 3 Clamping screw for fastening the focusing stop



Fig. 9 Leica FluoCombi III™ from below

- 1 Transport safety screws

2.6 Transport anchorage

- ▶ Remove transport locking screws (9.1) on both sides of the FluoCombi III™ and screw them into the respective threads for storing for transport at a later time.
- The swinging mechanism is now released.

! Always secure the FluoCombi III™ during transport with these two transport safety screws. Otherwise, the mechanism could be damaged and maladjusted.



2.7 FluoCombi III™ → focusing drive

! The Leica FluoCombi III™ must never be unscrewed. All mechanical and optical components are exactly adjusted at the factory.

To attach the FluoCombi III™ on the focusing drive, the mount thread for the stereo objective must be turned to the observer. Only in this position is the thread accessible for mounting the FluoCombi III™.

- ▶ Turn the thread for the stereo objective (10.1) to the observer by using the swinging mechanism. Only in this position is the thread accessible for mounting the FluoCombi III™ on the focusing drive.
- ▶ Fit in and hold FluoCombi III™ (10.2) in the two plugs (at the back of the yoke, not visible in the figure) on the focusing drive.
- ▶ Insert the hexagon-head screw (10.3) through the bore and tighten it on the focusing drive.

Fig. 10 Leica FluoCombi III™ from the front
1 Mount for stereo objective
2 Leica FluoCombi III™
3 Hexagon-head screw for fastening the FluoCombi III™ on the focusing drive

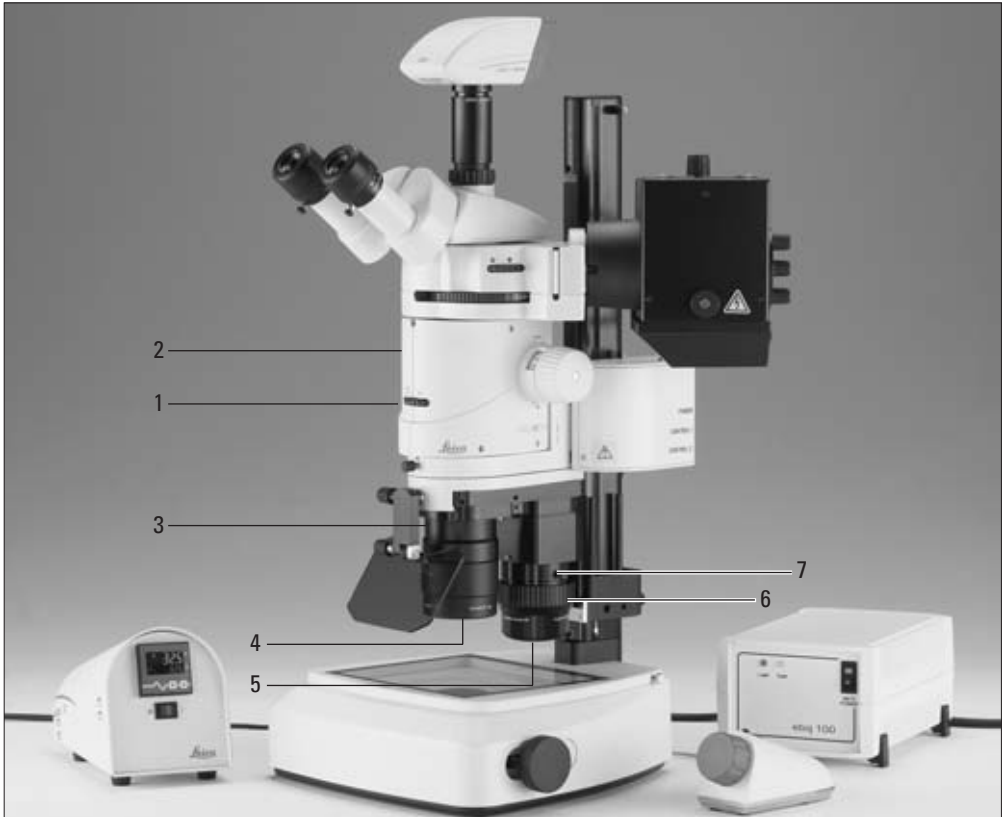

Fig. 11 Leica Fluocombi III™ with Leica MZ16 F

- | | |
|--|--|
| <p>1 Clamping screw for fastening the optics carrier</p> <p>2 MZ16 F, MZ16 FA optics carrier</p> <p>3 Thread for plan or planapo objective 1×</p> | <p>4 Plan or planapo objective 1×</p> <p>5 Thread for HR objective</p> <p>6 Fine focusing</p> <p>7 Clamping screw for fixing the fine focusing</p> |
|--|--|

2.8 FluoCombi III™ → optics carrier



The optics carrier may not be laterally rotated in the microscope carrier of the FluoCombi III™ since the 3rd beam path of the stereomicroscope and the FluoCombi III™ are adjusted to each other.

- ▶ Loosen the clamping screw (11.1) and remove the dust cover in the microscope carrier of the FluoCombi III™.
- ▶ Carefully insert the optics carrier (11.2) in the microscope carrier and align it so that the optics carrier is flush with the microscope carrier.
- ▶ Tighten the clamping screw (11.1).

The assembly of the remaining components is similar to the binocular tube, eyepieces, etc., see M2-105-0, and the fluorescence illumination, see M2-160-0.

2.9 Objectives

FluoCombi III™ is adjusted so that the focused position remains sharp (parfocal) and centered (parcentric) with every zoom position if used with a 1× plan or planapo objective and a 5× or 20× HR objective in the stereo and micro mode.

Hold the objectives during assembly and disassembly so that they do not fall onto the stage plate. Remove specimens from the stage plate.

- ▶ Turn the thread for the stereo objective (11.3) to the observer by using the swinging mechanism.
- ▶ Tighten the 1× plan or planapo objective (11.4) counterclockwise in the thread mount.

- ▶ Turn the thread for the micro objective (11.5) to the observer.
- ▶ Hold the fine focusing (11.6) or lock it with the clamping screw (11.7).
- ▶ Tighten the 5× HR objective counterclockwise in the thread mount.

OR

- ▶ Tighten the adapter (13.1) for Mitutoyo/Optem objectives and in the thread (6.5) using the screw-in adapter (13.2).
- ▶ Tighten the corresponding objective at the adapter (13.1).



Fig. 12 HR planapo objective 5×



Fig. 13

- 1 Adapter for Mitutoyo/Optem objectives
- 2 Screw-in adapter

2.10 UV protection screen



Never work without UV protection screen!

- ▶ Fasten the holder with UV protection screen (14.1) at the mount (14.2) using the clamping screw (14.3).
- ▶ Loosen the clamping screw (14.4).
- ▶ Tilt the UV protection screen (14.1) so that the operator cannot look directly onto the light spot.
- ▶ Tighten the clamping screw (14.4).



Fig. 14 UV protection screen

- 1 UV protection screen with holder
- 2 Mount for UV protection screen
- 3 Clamping screw for fastening the UV protection screen
- 4 Clamping screw for locking the UV protection screen in the desired tilt
- 5 Slot with dichroic mirror

2.11 Dichroic mirrors

Use dichroic mirrors (2-color-coated) in the FluoCombi III™ analogous to the filter sets used in the filter changer of the stereomicroscope. The mount of the dichroic mirror is magnetically fixed in the mount to ensure a correct alignment.

- ▶ Insert the mount with the dichroic mirror (Fig. 6) in the slot for the filter slide (14.5) so that the guide pin points down and the marking can be read on the outside.

Dichroic mirror

GFP
GFP Plus
GFP Plant
UV
Blue
Green
Texas Red
CFP
YFP
DsRED

marking

GFP1
GFP2
GFP3
UV
B
G
TXR
CFP
YFP
DSR

2.12 Illumination



Please adjust the Hg lamp precisely according to the M2-160-0 operating instructions so that you can achieve a homogenous light spot and good fluorescence even in micro mode.

3. Operation

3.1 Setting the parfocality

If a 1× plan or planapo objective and a 5× or 20× HR objective is used, the focused position in stereo and micro mode remains sharp (parfocal) and centered (parcentric) with every zoom position. For this reason, it is important to adjust the parfocality precisely as described.

- We recommend performing the diopter setting in transmitted or incident light. If the fluorescence illumination is activated, block the light using the light stop and rotate the dummy filter carrier into the beam path.
- Use a very fine, flat object that can still be focused with precision at the highest magnification.
- Zooming, focusing and adjusting interpupillary distance, eyecups, diopter settings, working distance, illumination see M2-105-0 or M2-160-4 (MZ16 FA) and M2-160-5 (MZ16 F) operating instructions.

The following settings must be performed by every user only once.

3.1.1. Stereo mode



Ensure that the focusing stop (15.4) is set so that the micro objective can never hit the stand or table surface or the object during focusing and swinging (see Chapter 2.5).

- ▶ Swing the 1× plan or planapo objective (15.1) to the observer.
- ▶ Set the eye lenses at both eyepieces to diopter setting «0».
- ▶ Select the lowest zoom setting.
- ▶ Set the working distance (15.2) with the coarse focusing drive: 60mm for 1× plan, 55mm for 1× planapo.

- ▶ Observe a flat test object and focus with fine focusing drive.
- ▶ Select the highest zoom setting.
- ▶ Optimize the image sharpness.
- ▶ Rotate the eye lenses counterclockwise in the direction of «+» until the stop (+5 diopter setting). Do not look into the eyepieces during the procedure.
- ▶ Select the lowest zoom setting.
- ▶ Look into the eyepieces and close one eye each. Observe the test object with one eye and slowly rotate the eye lens at the respective eyepiece clockwise in the direction of «-» until the view of the test object is sharp. Repeat the same for the other eye.



Fig. 15 Planapo objective 1× rotated into the beam path

- 1 Planapo objective 1×
- 2 Working distance
- 3 HR planapo objective 5×
- 4 Focusing stop

Checking the parfocality:

- ▶ Select the highest zoom setting.
- ▶ Observe the test object with both eyes and adjust the focus, if necessary.
- ▶ Check the image sharpness from the lowest to the highest zoom position.
 - The image sharpness must remain constant (parfocal). If this is not the case, repeat the procedure.

3.1.2. Micro mode

- ▶ Swing the HR objective (16.1) to the observer.
- ▶ Select the lowest zoom setting.
- ▶ Sharply focus the object with fine focusing (16.2).
Working distance with 5× HR objective: 19mm
and with 20× HR objective 13mm.
- ▶ Refocus little by little and continuously up to the highest zoom position.
- ▶ Lock the fine focusing with the clamping screw, if needed, to avoid unintentional adjustment changes.

The focused position now remains sharp (parfocal) and centered (parcentric) in stereo and micro mode for every zoom position.

3.2 Magnification, field of view

The magnification changer is effective in stereo and micro mode. Magnification factors of the micro objectives with Leica:

- HR objective 5×: 4×
- HR objective 20×: 8×

The table with the optical data is located on page 22.



Fig. 16 HR planapo objective 5× rotated into the beam path

- 1** HR planapo objective 5×
- 2** Fine focusing
- 3** Planapo objective 1×

4. Appendix

4.1 Weights

FluoCombi III™	3.220kg
HR planapo objective 5×	0.5kg
HR objective 10×	0.2kg
HR objective 20×	0.2kg
Planapo objective 1×	0.74kg
Plan objective 1×	0.78kg
Leica MZ16 F optics carrier	3.420kg
Leica MZ16 FA optics carrier	3.14kg
Optics carrier	3.82kg
ErgoTube™ 10°–50°	1.7kg
Trinocular video/photo tube 100%	1.595kg
Wide-field eyepieces for persons wearing glasses 10×/21B	0.158kg
GFP filter set	0.04kg
UV filter set	0.06kg
Lamp housing 106Z for 50 W	2.26kg
Lamp housing 106Z for 100 W	2.4kg
Hg lamp 50 W	0.1kg
Hg lamp 100 W	0.08kg
Stray-light protection	0.58kg

4.2 Dimensions

HR planapo objective 5×

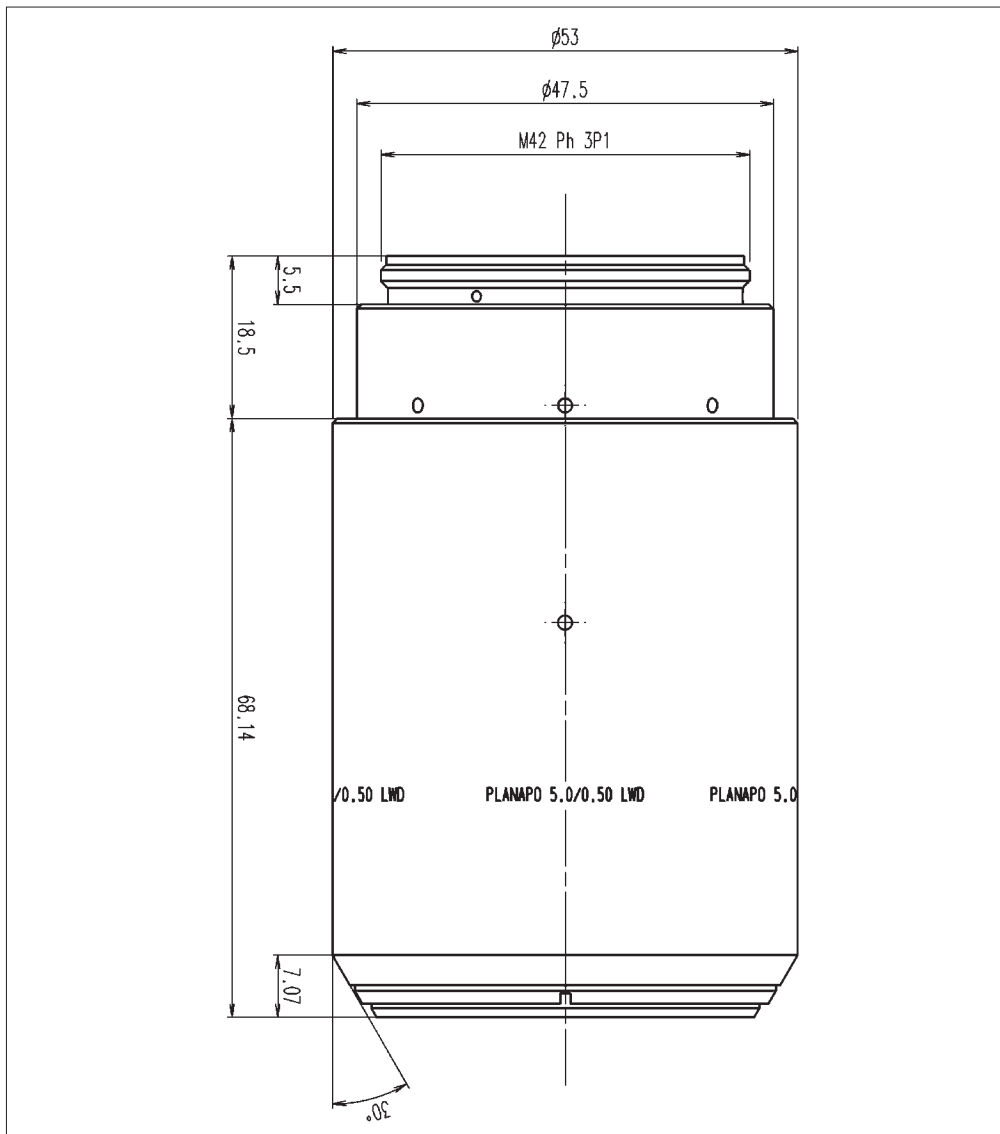

Leica FluoCombi III™

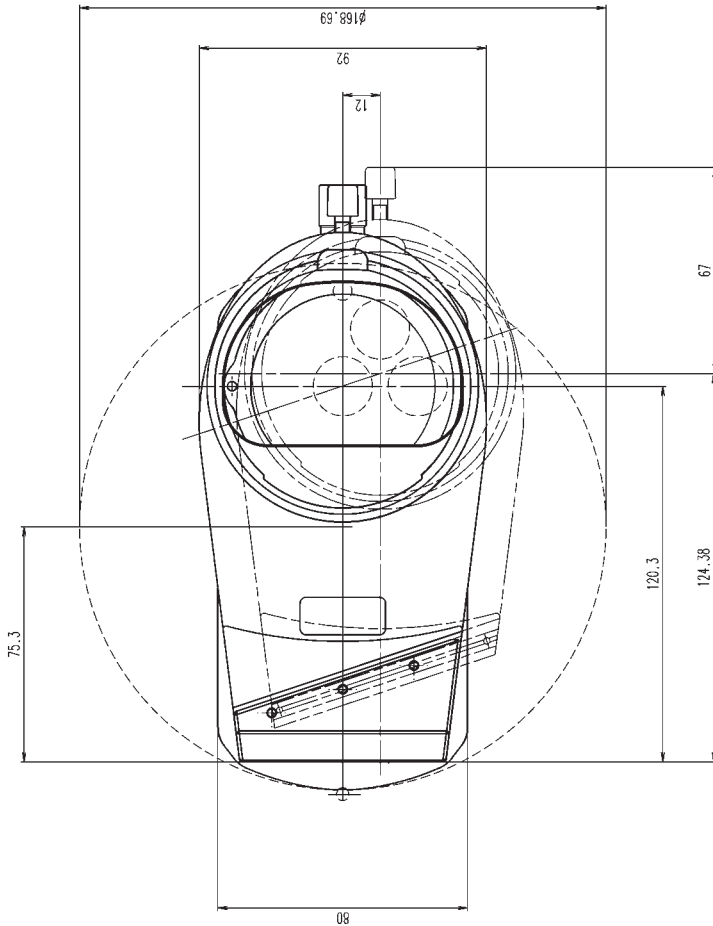

Dimensions in mm

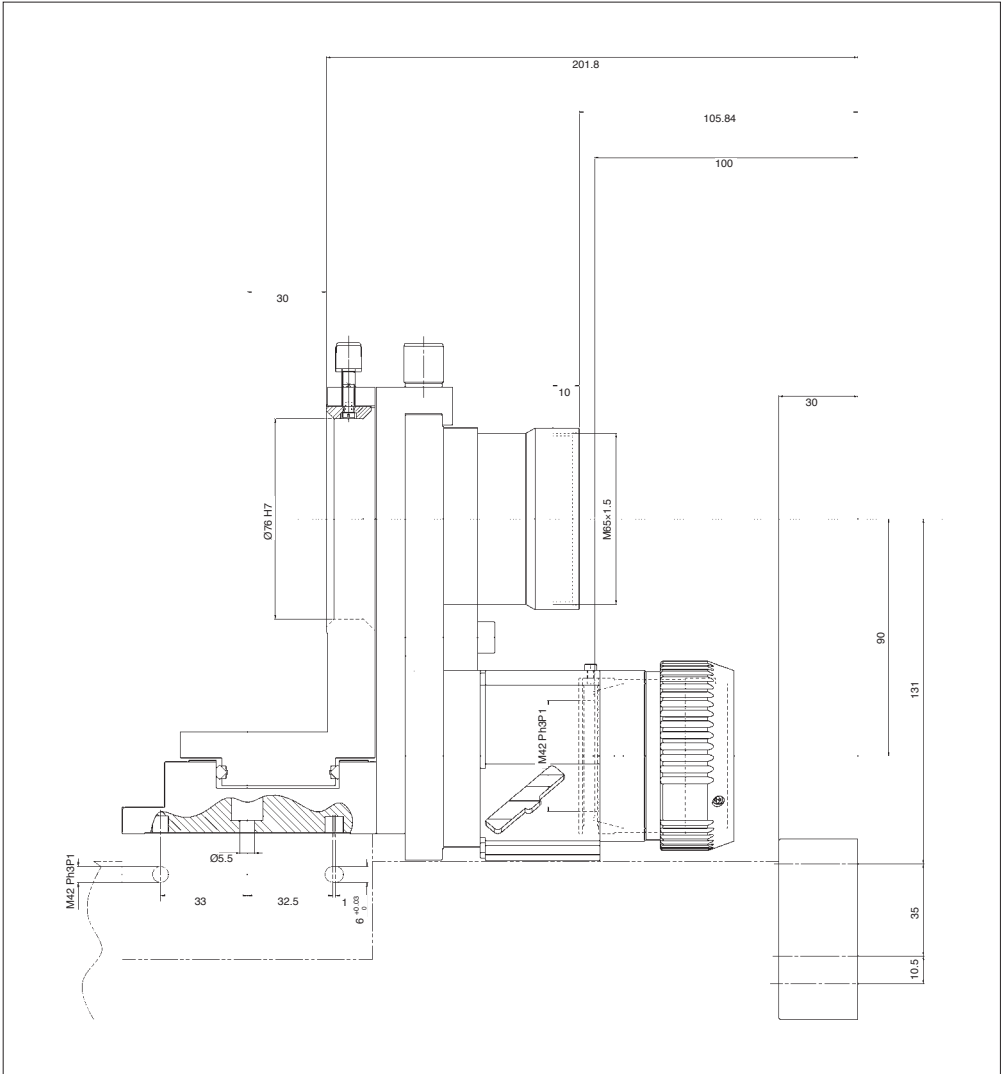

Dimensions in mm

4.3 Optical data

Leica MZ16 F and MZ16 FA

Objective Planapo 5×/0.5 (10447243)
Factor 4×
Iris diaphragm open
Working distance 19.8mm

Eyepiece 10×/21B

Zoom position	Total magnification	Field of view diameter (mm)	Numerical aperture	Resolution (lp/mm)	Visible structure width (µm)
0.71	28.4×	1.6	0.084	252	3.97
1	40×	1.6	0.11	336	2.98
1.6	64×	1.6	0.17	504	1.98
2	80×	1.6	0.2	612	1.63
2.5	100×	1.6	0.24	732	1.37
3.2	128×	1.6	0.3	888	1.13
4	160×	1.31	0.34	1032	0.97
5	200×	1.05	0.4	1200	0.83
6.3	252×	0.83	0.45	1344	0.74
8	320×	0.66	0.49	1488	0.67
10	400×	0.53	0.5	1500	0.67
11.5	460×	0.46	0.5	1500	0.67

Eyepiece 16×/14B

Zoom position	Total magnification	Field of view diameter (mm)	Numerical aperture	Resolution (lp/mm)	Visible structure width (μm)
0.71	45.4×	1.6	0.08	252	3.97
1	64×	1.6	0.11	336	2.98
1.6	102×	1.6	0.17	504	1.98
2	128×	1.6	0.20	612	1.63
2.5	160×	1.4	0.24	732	1.37
3.2	205×	1.1	0.3	888	1.13
4	256×	0.87	0.34	1032	0.97
5	320×	0.7	0.4	1200	0.83
6.3	403×	0.56	0.45	1344	0.74
8	512×	0.44	0.49	1488	0.67
10	640×	0.35	0.5	1500	0.67
11.5	736×	0.3	0.5	1500	0.67

4.4 Technical data

Leica FluoCombi III™	
Type	Accessories with quick changer for Leica fluorescence stereomicroscopes MZ16 FA, MZ16 F, for a stereomicroscope objective (3D-view) and an HR objective (microscopic resolution)
Optics	Multiple-coated high-performance optics, lead-free, maximum resolution with micro objective; beam splitter for binocular observation
Mechanics	360° rotation and lateral movement, TripleBeam™, fine focusing, safety focus stop
Parfocal / parcentric	– Objective change between 1× plan or planapo and 5× HR objectives at constant image sharpness – adjustable fine focusing for micro objective
Fine focusing	integrated
Dichroic mirrors	GFP, GFP+, GFP Plant, UV, Blue, Green, CFP, YFP, Texas Red, DsRed, CY5, CY7, magnetically fixed
Micro objectives	
HR planapo 5×	with MZ16 F / MZ16 FA – Numerical aperture: 0.5 – Resolution: 1500 Lp/mm – Finest visible structure width 0.3µm – Working distance: 19mm – Magnification factor: 4× – Magnification: 460× with 10× eyepieces – 736× with 16× eyepieces
Adapter	For Mitutoyo/Optem objectives
Fluorescence stereomicroscopes	
Designation	– Leica MZ16 F with 16:1 zoom – Leica MZ16 FA, motorized, with 16:1 zoom
Microscope type	Stereomicroscopes with patented TripleBeam® third beam path and patented FLUOIII® fluorescence filter system, lead-free glass
Rapid filter changer	horizontal FLUOIII® quick changer for 4 filter sets
Fluorescence filters	– Excitation and suppression filter sets: GFP, GFP+, GFP Plant, UV, Blue, Green, CFP, YFP, TXR, DSR, Cy3™, Cy5™ – Slot for filter slide for neutral density filters
Illumination	– TripleBeam®: 3rd beam path for fluorescence light – 100-W or 50-W high-pressure lamp, chromatically corrected collector, focusable, lamp mount can be centered
Extensive UV protection	UV protection screen, UV barrier filter, stray-light protection for lamp housing and dummy filter carrier for empty filter positions
Stereo objective	1× planapo or plan: 0.125 NA, 2.7µm resolution 2× planapo: 0.25 NA, 1.3µm resolution, 750 Lp/mm
Working distance (stereo)	60mm (1× plan), 55mm (1× planapo), 15mm (2× planapo)
Eyepieces	Ergonomic wide-field eyepieces for eyeglass wearers 10×/21, 16×/14 with high field number, distortion-free, lead-free glass

Accessories

Ergonomics	<ul style="list-style-type: none">– Apochromatic ErgoTube® with variable viewing angle 10°–50°– ErgoWedge® 5°–25°– Trinocular tube– Motor focusing system with 0.7µ resolution– Gliding stage
Stands	<ul style="list-style-type: none">– High-performance transmitted-light base HL RC™– Transmitted-light bases bright field/dark field– Incident-light bases– Anti-vibration platform– 500mm focusing drive, coarse/fine with 1µ resolution
Specialty stages	<ul style="list-style-type: none">– Gliding stage– Thermocontrol System Leica MATS
Accessories	<ul style="list-style-type: none">– FireWire digital camera systems for fluorescence– Analog and video cameras– Image processing and analysis software (IM1000, FW4000, QWin)– Measurement graticules

Leica Microsystems – the brand for outstanding products

Leica Microsystems' mission is to be the world's first-choice provider of innovative solutions to our customers' needs for vision, measurement, lithography and analysis of microstructures.

Leica, the leading brand for microscopes and scientific instruments, developed from five brand names, all with a long tradition: Wild, Leitz, Reichert, Jung and Cambridge Instruments. Yet Leica symbolizes innovation as well as tradition.

Leica Microsystems – an international company with a strong network of customer services

Australia:	Gladesville, NSW	Tel. +1 800 625 286	Fax +61 2 9817 8358
Austria:	Vienna	Tel. +43 1 486 80 50 0	Fax +43 1 486 80 50 30
Canada:	Richmond Hill/Ontario	Tel. +1 905 762 20 00	Fax +1 905 762 89 37
China:	Hong Kong	Tel. +8522 564 6699	Fax +8522 564 4163
Denmark:	Herlev	Tel. +45 44 5401 01	Fax +45 44 5401 11
France:	Rueil-Malmaison Cédex	Tel. +33 1 4732 8585	Fax +33 1 4732 8586
Germany:	Bensheim	Tel. +49 6251 1360	Fax +49 6251 136 155
Italy:	Milan	Tel. +39 02 57 486 1	Fax +39 02 5740 3273
Japan:	Tokyo	Tel. +81 3 543 596 09	Fax +81 3 543 596 15
Korea:	Seoul	Tel. +82 2 514 6543	Fax +82 2 514 6548
Netherlands:	Rijswijk	Tel. +31 70 41 32 130	Fax +31 70 41 32 109
Portugal:	Lisbon	Tel. +35 1 213 814 766	Fax +35 1 213 854 668
Singapore:		Tel. +65 6 77 97 823	Fax +65 6 77 30 628
Spain:	Barcelona	Tel. +34 93 494 9530	Fax +34 93 494 9532
Sweden:	Sollentuna	Tel. +46 8 625 45 45	Fax +46 8 625 45 10
Switzerland:	Glattbrugg	Tel. +41 44 809 34 34	Fax +41 44 809 34 44
United Kingdom:	Milton Keynes	Tel. +44 1908 246 246	Fax +44 1908 609 992
USA:	Bannockburn/Illinois	Tel. +1 800 248 0123	Fax +1 847 405 0164

and representatives of Leica Microsystems
in more than 100 countries.

In accordance with the ISO 9001 certificate, Leica Microsystems (Switzerland) Ltd, Business Unit Stereo & Microscope Systems has at its disposal a management system that meets the requirements of the international standard for quality management. In addition, production meets the requirements of the international standard ISO 14001 for environmental management.

Leica Microsystems (Switzerland) Ltd
Stereo & Microscope Systems
CH-9435 Heerbrugg

Telephone +41 71 726 33 33
Fax +41 71 726 33 99
www.leica-microsystems.com
www.stereomicroscopy.com

The companies of the Leica Microsystems Group operate internationally in four business segments, where we rank with the market leaders.

• Microscopy Systems

Our expertise in microscopy is the basis for all our solutions for visualization, measurement and analysis of microstructures in life sciences and industry. With confocal laser technology and image analysis systems, we provide three-dimensional viewing facilities and offer new solutions for cytogenetics, pathology and materials sciences.

• Specimen Preparation

We provide comprehensive systems and services for clinical histo- and cytopathology applications, biomedical research and industrial quality assurance. Our product range includes instruments, systems and consumables for tissue infiltration and embedding, microtomes and cryostats as well as automated stainers and coverslippers.

• Medical Equipment

Innovative technologies in our surgical microscopes offer new therapeutic approaches in microsurgery.

• Semiconductor Equipment

Our automated, leading-edge measurement and inspection systems and our E-beam lithography systems make us the first choice supplier for semiconductor manufacturers all over the world.

M I C R O S Y S T E M S