

**STANDARD ILLUMINATORS**



**MODEL 180**  
**Standard 150 Watt Illuminator**

The Model 180 is a 150 Watt quartz halogen illuminator that can deliver upwards of 40,000 footcandles of high intensity, cold illumination. It was specifically designed to be durable with the lowest possible audible noise and vibration levels typically required in most machine vision applications. The unit is compatible with all of the Fiber-Lite® standard and custom fiber optic light guides.

**FEATURES:**

*110 or 220 VAC 50/60 Hz*

*Durable with low audible noise (25dB) and vibration levels*

*Rheostat controlled intensity, 50-100%*

*40,000 footcandles of high intensity, cold illumination*

*Uses EKE lamp with optional EJV lamp for higher output*

*UL listed and CSA approved*

**TECHNICAL INFORMATION:**

<b>Lamp:</b>	EKE, 21 Volt, 150 Watt	EJE, 21 Volt, 150 Watt
<b>Lamp Life:</b>	200 Hrs. at full intensity	40 Hrs. at full intensity
<b>Color Temperature:</b>	3200° K	3400° K
<b>Intensity Control:</b>	Reheostat 50-100%	
<b>Voltage:</b>	110/120 VAC, 50/60 Hz, 220/230 VAC, 50/60 Hz	
<b>Fuse:</b>	2.5A 250V 3AG slow blow (115 VAC) 1.25A 250V 3AG slow blow (230 VAC)	
<b>Noise Level:</b>	25 db	
<b>Safety Approvals:</b>	UL, CSA	
<b>Dimensions:</b>	5.87" x 6.5" x 9"; 14.9 x 16.5 x 22.9 cm	
<b>Weight:</b>	9 lbs.	
<b>Adapters:</b>	A-type adapter series	
<b>Housing Temperatures:</b>	100°F (37.8°C)	



**STANDARD ILLUMINATORS**

Mechanical Specifications:

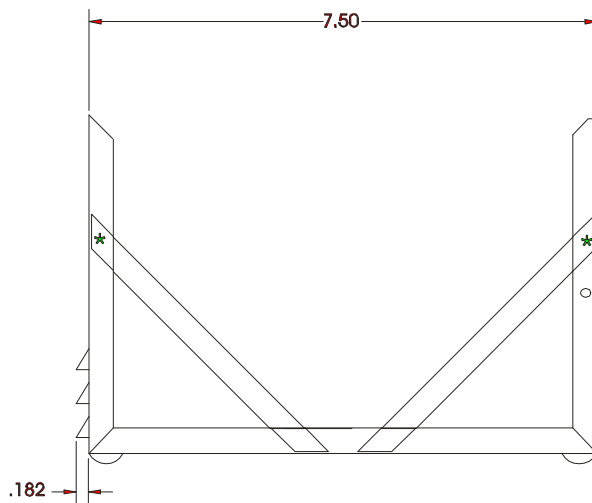
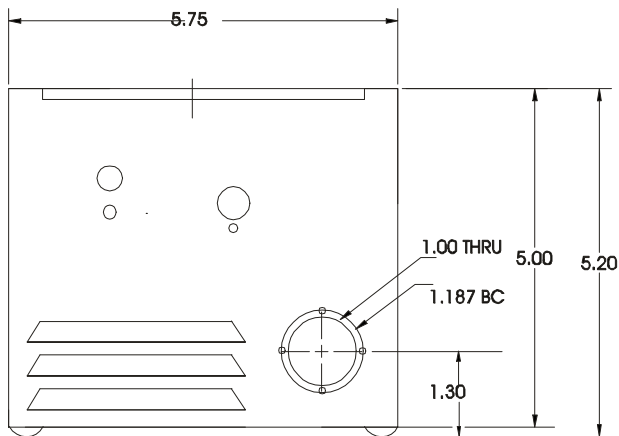
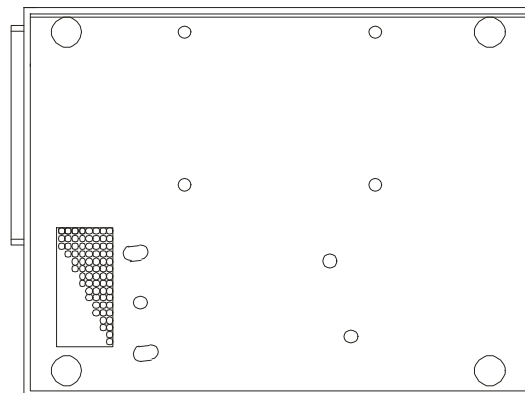
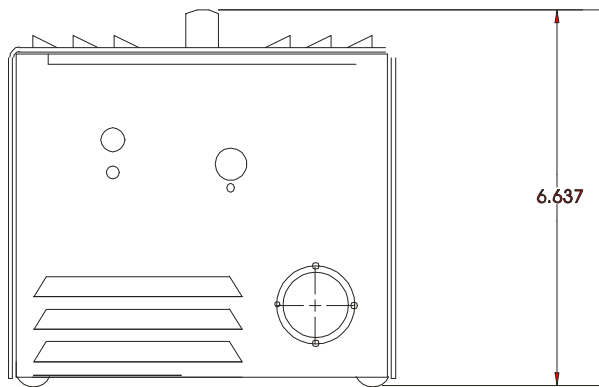

PRODUCT SALES CODES:

**SALES CODE Description**

- 180** 150 Watt Quartz Halogen Illuminator
- 180/220** 150 Watt Quartz Halogen Illuminator 230 VAC operation