



KL 1500 LED

- Multiple LED light engine
- Wide range power supply (90–264 V, 47–63 Hz) with international clip plug system
- Silent fan cooling
- Continuous dimming from 0 to 100%
- Compact high quality housing with integrated handle
- Small footprint and additional iron ballast for stability when used with goosenecks
- Filter slider with two positions (filter can remain in the light source even if it is not used)
- Easy to use fixture mechanism with clamping screw
- Comprehensive range of lightguides and accessories available (KL 1500 series)
- **Approvals:**
The KL 1500 LED is in compliance with the CE regulations (power supply CE, UL, PSE)
- Manufactured in the EU

KL 1500 LED

A benchmark in the field of LED light sources

The KL 1500 LED is a fiber optic light source with a multiple LED light engine, designed for industrial and life science applications in Stereo Microscopy and Macroscopy.

The brightness is equivalent to a 150-Watt halogen cold light source.

All advantages of LED light sources,

- *no bulb changing*
- *low energy consumption*
- *ripple free DC illumination*
- *white light (daylight)*
- *no visible color temperature shift on dimming*

are combined with the main advantages of fiber optics,

- *very high light intensity focused to a small field of view*
 - *high flexibility of light and illumination techniques*
- for an outstanding price performance ratio.

KL 1500 LED

KL 1500 LED		
General data		
Part-No.		150 400
Dimensions (W x D x H)	(mm)/(inch)	220 x 113 x 137/8.7" x 4.5" x 5.4"
Weight	(kg)	Approx. 1.75
Cooling		Silent fan
Electrical data		
Operating voltage, frequency		90 – 264 V ~, 47 – 63 Hz
Power consumption	(VA)	Max. 30
Protection class		II
Overvoltage category		II
Diodes		Cree Xlamp high power LEDs
LED power rating	(W)	7 x 3.5
LED life time	(h)	50.000
Illumination data		
Light flux	(lm)	380
Color temperature	(K)	Approx. 6.000
Light control		Electrical
Active light guide diameter	(mm)/(inch)	Max. 9/Max. 0.35"
Certification marks		
Approvals		CE (power supply CE, UL, PSE)
EMV-class		B

Product improvements may result in specification or feature changes without notice.

KL 1500 LED

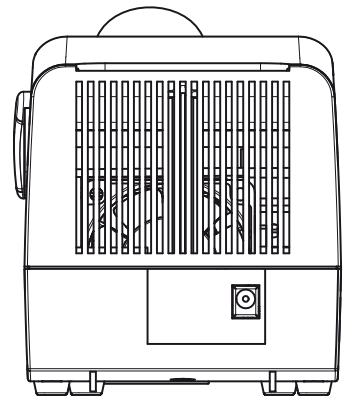
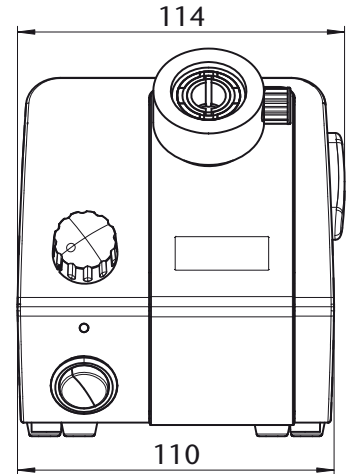
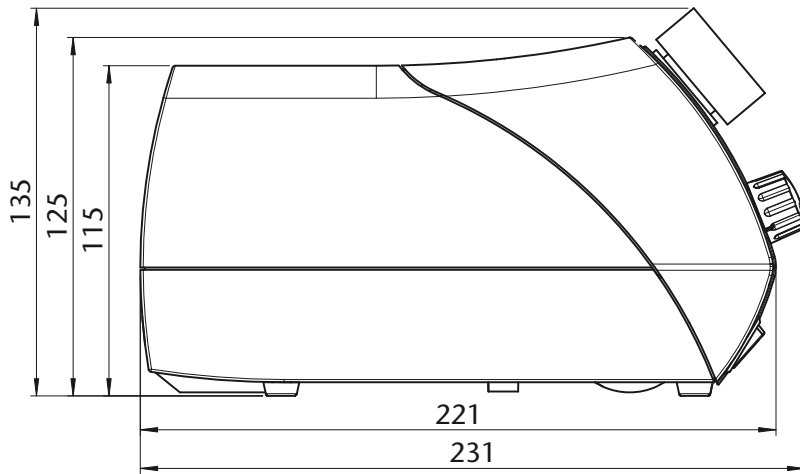

Lighting and Imaging
SCHOTT North America, Inc.
122 Charlton Street
Southbridge, MA 01550-1960
USA

Phone: +1 508/765-9744
Fax: +1 508/764-6273
lightingimaging@us.schott.com
www.us.schott.com/lightingimaging

For your local sales contact please visit
www.us.schott.com/lightingimaging

SCHOTT
glass made of ideas