



KL 200 LED

- LED light engine.
- Wide range power supply (100–240 V, 50–60 Hz) with international clip plug system.
- Convection cooling (no fan).
- Continuous dimming from 0 to 100%.
- Mountable direct to microscope stands via respective adaptors or usable as standallone.
- Wide range of accessories available (KL 200 series).
- **Approvals:**
The KL 200 LED is in compliance with the CE regulations.
(Power supply: CE, UL, PSE)
- Manufactured in the EU.

Mounting adaptors	
for microscope and swinging arm stands	
bracket for column Ø 25 mm (0.98")	120 225
bracket for column Ø 29 mm (1.14")	120 229
bracket for column Ø 32 mm (1.26")	120 232
bracket for column Ø 35 mm (1.38")	120 235
for standalone application	
Base stand	158 340
Mounting bracket	120 250

Note: Mounting adaptors must be ordered separately!

KL 200 LED

compact and bright

The KL 200 LED is a fiber optic routine light source with a LED light engine, developed and designed for industrial and life science applications in Stereo Microscopy and Macroscopy.

The brightness is equivalent to a 20-watt halogen cold light source.

All advantages of LED light sources,

- *no bulb changing*
- *low energy consumption*
- *ripple free DC illumination*
- *white light (daylight)*

are combined with the main advantages of fiber optics,

- *significantly higher light intensity focused to a small field of view*
- *high flexibility of light and illumination techniques*

for an outstanding price performance ratio.

KL 200 LED

General data

Part-No.		120 200
Dimensions (W x D x H)	(mm)/(inch)	106 x 114 x 59/4.2" x 4.5" x 2.3"
Weight	(kg)	Approx. 0.35
Cooling		Convection

Electrical data

Operating voltage, frequency		100–240 V ~, 50–60 Hz
Power consumption	(VA)	Max. 5
Protection class		II
Overvoltage category		II
Diode		LED, Luxeon Rebel
LED power rating	(W)	3
LED life time	(h)	50,000

Illumination data

Light flux	(lm)	50
Color temperature	(K)	Approx. 5,600
Light control		Electrical
Active light guide diameter	(mm)/(inch)	Max. 6/max. 0.23"

Certification marks

Approvals		CE (power supply: CE, UL, PSE)
EMV-class		B

Product improvements may result in specification or feature changes without notice.

KL 200 LED

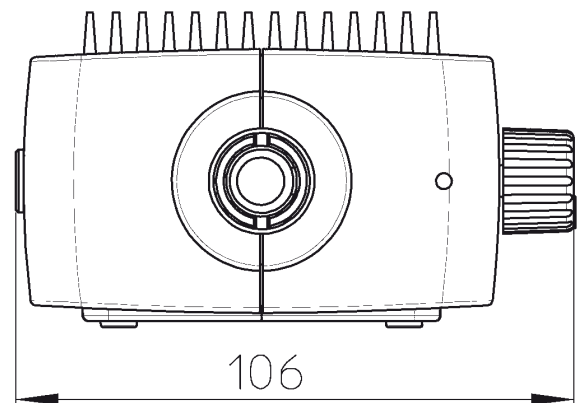
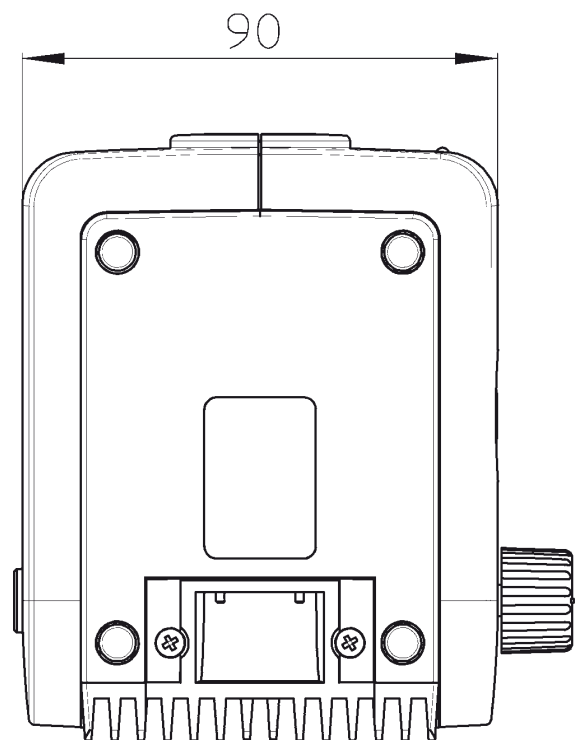
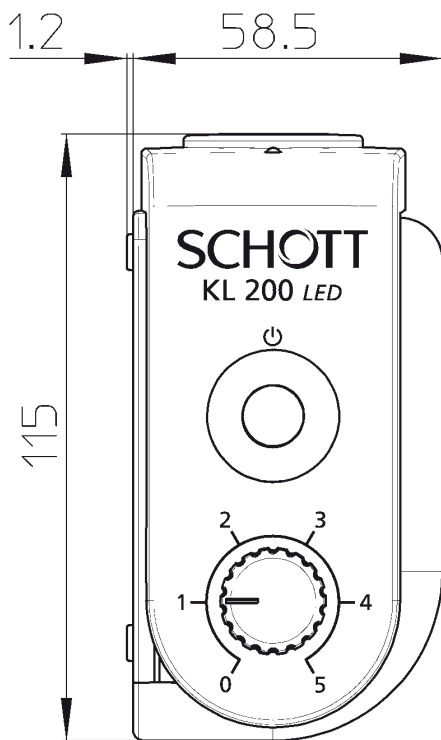

Lighting and Imaging
SCHOTT North America, Inc.
122 Charlton Street
Southbridge, MA 01550-1960
USA

Phone: +1 508/765-9744
Fax: +1 508/764-6273
lightingimaging@us.schott.com
www.us.schott.com/lightingimaging

For your local sales contact please visit
www.us.schott.com/lightingimaging

SCHOTT
glass made of ideas