



KL 200

KL 200

Compact and capable

The KL 200 is a compact, easy-to-use, 20-Watt light source with small space requirements but big performance. The KL 200 has an attractive modern design and is manufactured using quality materials. The KL 200's ease of operation underlies its professional quality, illuminating objects perfectly.

The brightness of the 20-Watt light source can be controlled in three stages. When stage 1 is used the light reflector bulb can expect to render a service life of 10,000 h, at stage 3 the service life is around 300 h. At this stage a color temperature of 3200 K is achieved, making it ideal for use with artificial light films.

- **Easy Maintenance:** No tools are required to replace the reflector bulb. When the bulb compartment is opened, the electrical supply is interrupted for safe exchange of the bulb.
- **Ergonomical for Work Areas:** Since no fan is required for this model, the light source is absolutely vibration and noise free.
- **Extensive Range of Accessories:** The KL 200 can be used in a wide variety of applications. For hobby or professional needs, wherever fiber optic illumination is needed, SCHOTT can provide the suitable accessories.
- **Approvals:** The KL 200 has been tested and approved in accordance with the relevant safety standards. The KL 200 is CSA compliant and bears the European conformity CE sign.
- **Manufactured in the EU.**

KL 200			
Type designation		General data	
Dimensions (W x D x H)	(mm)/(inch)	125 x 205 x 120/4.9" x 8" x 4.7"	
Weight	(kg)	Approx. 1.5	
Cooling		Natural convection	
		Part-No.	Electrical data
Operating voltage	120 volt version	120 101	~ 50/60 Hz
	230 volt version	120 100	~ 50/60 Hz
Protection Class		II	
Lamp type		Halogen reflector lamp	
Lamp voltage rating (V)		8	
Lamp power rating (W)		20	
Average lamp service life (level III)	(h)	300	
Illumination data			
Light flux	(lm)	40	
Active light guide diameter	(mm)/(inch)	6/0.24"	
Light control		Electrical	

Product improvements may result in specification or feature changes without notice.

KL 200

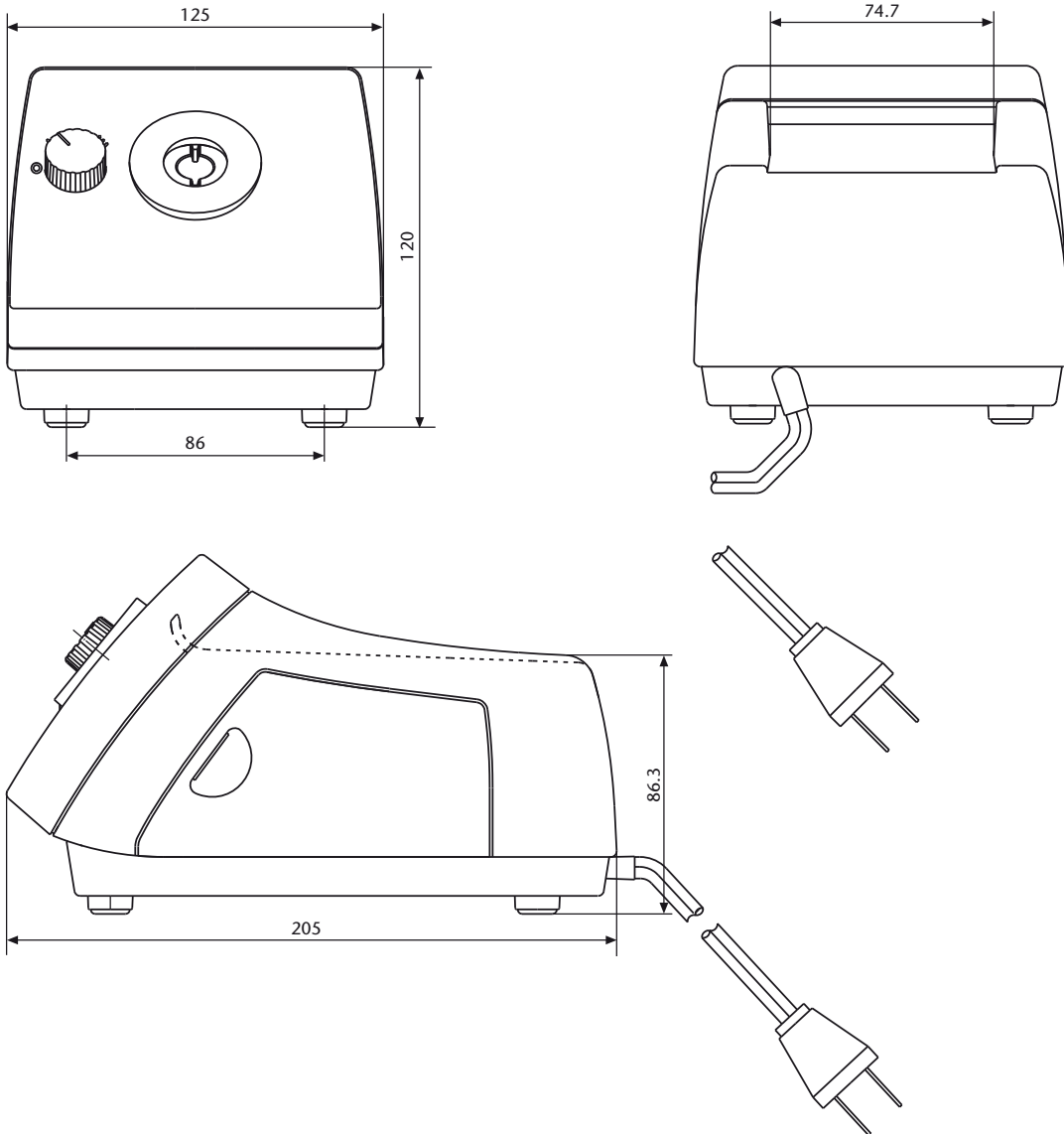

Lighting and Imaging
SCHOTT North America, Inc.
122 Charlton Street
Southbridge, MA 01550-1960
USA

Phone: +1 508/765-9744
Fax: +1 508/764-6273
lightingimaging@us.schott.com
www.us.schott.com/lightingimaging

SCHOTT
glass made of ideas

For your local sales contact please visit
www.us.schott.com/lightingimaging