

STEP

ZOOM

DIGITAL



Leica E-Serie - Instruction manual



Dear User

Thank you for your decision to use our product. We trust that you will find much enjoyment and success with the school stereo microscopes from Leica Microsystems.

The new stereomicroscope line is perfectly suited for practical instruction in schools and universities as well as for routine tasks in the laboratory and industrial production and Testing. Viewing entire objects under magnification imparts perspectives and discoveries that would not be possible with the naked eye.

In developing our stereomicroscopes, we have placed great emphasis on simple, self-explanatory directions. **However, please take the time to read the instruction manual and the notes on operating safety**, to learn about all the features and capabilities of your stereomicroscope so that you can use it safely and to its best advantage. Should you have any questions, please consult your local Leica representative. We are gladly at your service. CUSTOMER SERVICE is a big thing with us. Not only before the sale, but afterwards as well.

We are pleased to tell you about our instruction CD "Basic". This CD is designed to support teachers and trainers in explaining the elements of optical devices simply and clearly to their students. Starting with simple exercises, the object is to train and sharpen students' perceptiveness before they are introduced to and start to use the magnifier and the stereomicroscope. The first practical tasks with the Leica stereomicroscope are designed to inspire students with the enjoyment of using a microscope. Therefore, theoretical topics such as their laws of optics are deliberately only discussed where they are essential to an understanding of the practical activities. This material is dealt with thoroughly in the other two instruction CDs, "Standard" and "Advanced".

Leica Microsystems (Switzerland) Ltd.
Business Unit Stereo & Macroscopic Systems
www.leica-microsystems.com/education



Table of contents

Scope of delivery and general notes	3
Description of the device	4
Device variants	5
Magnification display	6
Illumination	7
Starting the Leica ES2:	8
Eye distance / Focussing / Zoom / Light control	
Starting the Leica EZ4:	9
Eye distance / Focussing / Zoom / Light control	
Leica EZ4 with open tubes	10
Overview of eyepieces	10
Optional accessories (for EZ4 with open tubes):	
Adjustable eyepieces: – Diopter settings from -5 to +5	11
– Settings for two adjustable eyepieces	12
Graticules / Inserting the graticule	13
Photographing with the Leica DC150 digital camera	14
Leica EZ4 D device overview	15
Photographing with the EZ4 D: Four different modes of use	16
Care and maintenance	17
Technical and optical data	
Stereomicroscope	18
Illumination system	19
Digital camera and accessories	20
Environmental conditions, weights	21
Optical data	22
Dimensions of the EZ4 with 10x eyepieces	23
Dimensions of the EZ4 with 16x eyepieces	25
Dimensions of the EZ4 with open tubes	27
Dimensions of the EZ4 D	29

Scope of delivery and general notes

With your stereomicroscope, you also receive:

- a laminated quick reference guide
- an interactive CD ROM with all necessary instructions for use
- a printed brochure containing the general safety instructions in 20 languages



All documents must be stored safely so that the user can refer to them at any time.

Instructions for use and updates are also available for download and printing on our homepage www.discovermicroscopy.com.

Please compare the contents of the package you receive carefully with the packing slip, the delivery note or the invoice.

We recommend that you keep copies of these documents together with the instructions for use.

When unpacking, please ensure that no small parts are left in the packaging material.



The instructions for use and the safety instructions are important parts of the device.

The instructions for use and particularly the safety instructions should be read carefully before starting and using the instrument. In order to maintain the device in its condition as new and to ensure safe operation, the user must heed the warnings.



According to our regulations (conforming to ISO 14001), we use packaging materials that allow of environmentally responsible recycling, and bubble wrap made according to the most recent technical discoveries (RESY).

Printed copies of the instructions for use are available from:

smspromotion@leica-microsystems.com

For the address of closest dealership to you, visit:

www.leica-microsystems.com

Your Leica Microsystems Ltd.

Description of the device

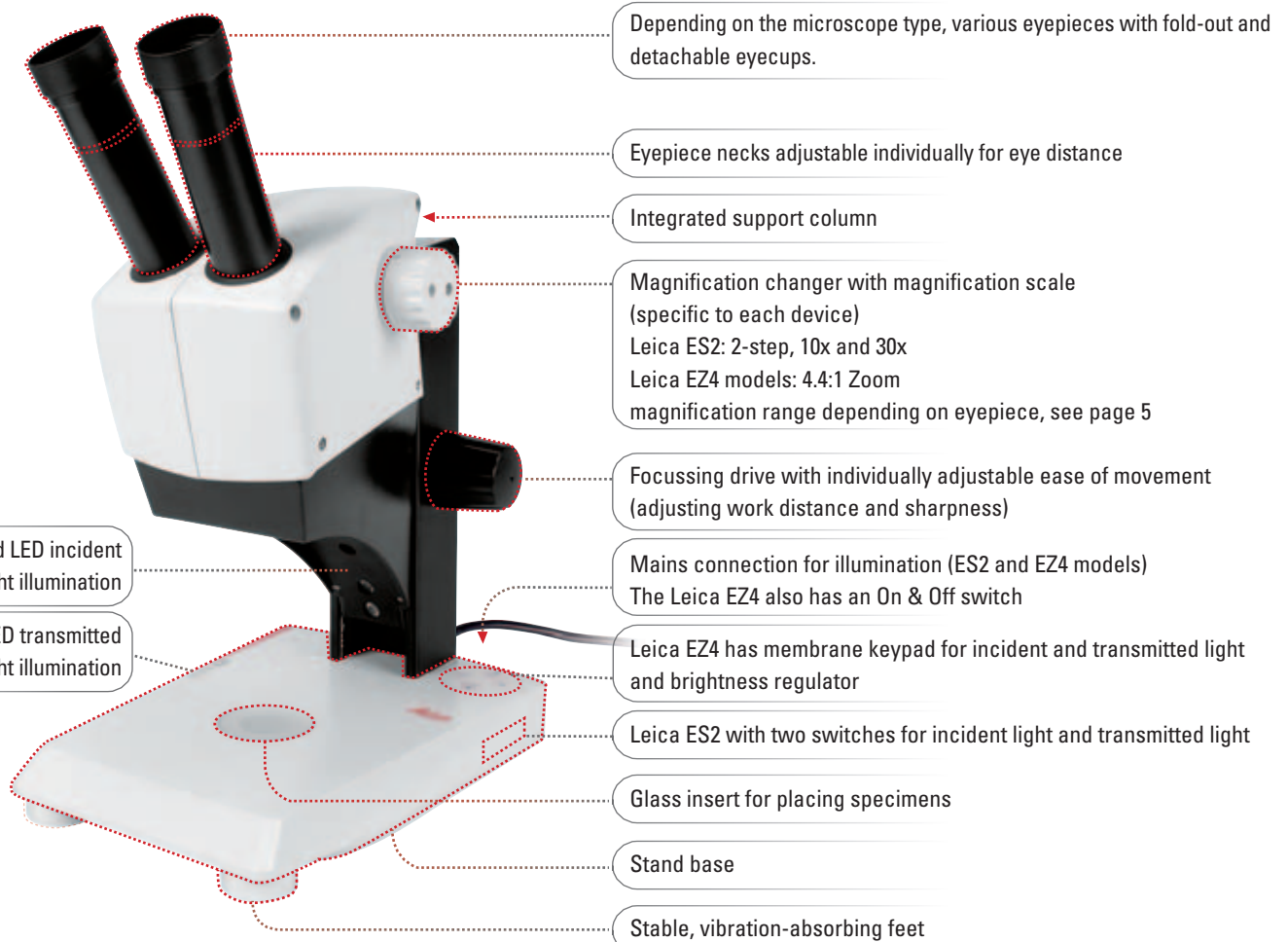
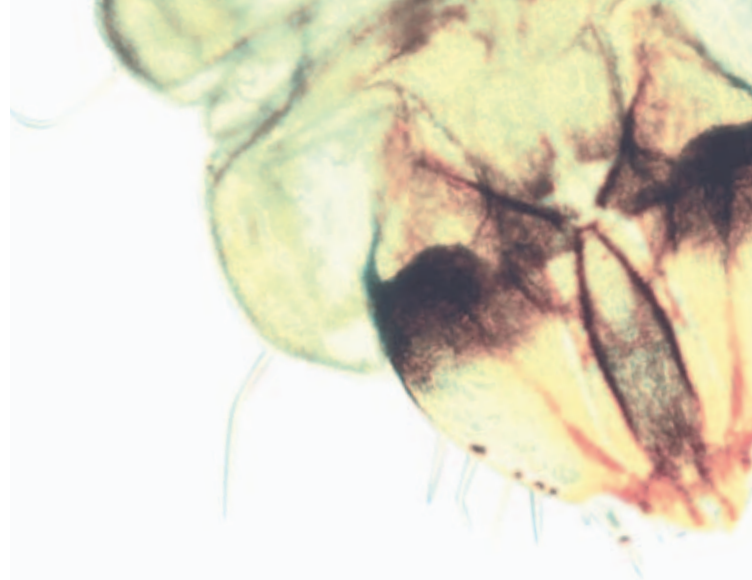

For more technical details about the EZ4 D, see page 15

Device variants

The Leica ES2, EZ4 and EZ4 D stereomicroscopes are precision optical instruments designed to render objects, object details and specimens from the fields of science and technology more easily visible through magnification.

The full apparatus consists of a Leica ES2, EZ4 or EZ4 D stereomicroscope according to choice, with the following integrated components:

- Tube
 - Integrated illumination
 - Focussing drive
 - Stand
 - Column
 - 10x or 16x eyepieces depending on variant
- On the Leica EZ4 with open tubes, the eyepieces are replaceable



Leica ES2:

- 2-step magnification changer 3:1
Magnifications 10x and 30x
- 10x fixed eyepieces for eyeglass wearers
- Integrated illumination for transmitted and incident light



Leica EZ4 D:

- All features as for the Leica EZ4 with fixed 10x eyepieces.
- Plus:
- Integrated 3.0 megapixel CMOS camera
 - Control software for PC and MAC
 - USB2.0 output
 - Analog video output
 - Integrated slot with 128 MB SD (Secure Digital) card



Leica EZ4:

- Zoom magnification changer 4.4:1
- Optionally available with fixed eyepieces for eyeglass wearers 10x or 16x
- Variant with open tubes for use of 10x, 16x, 20x eyepieces as desired or with Leica DC150 digital camera
- Magnification range:
 - 8x to 35x (with 10x eyepieces)
 - 12.8x to 56x (with 16x eyepieces)
 - 8x to 70x depending on the eyepiece used with the model with open tubes
- Integrated incident and transmitted light illumination with brightness regulation
- 3-way LED incident light illumination

Magnification display



On the Leica ES2 and EZ4 models with fixed eyepiece, the magnification set can be read easily on the knob on the right. The additional magnification provided by the eyepieces is already incorporated in the scale

Tables optical data including object field diameters see page 22

Leica ES2 with fixed 10x eyepieces

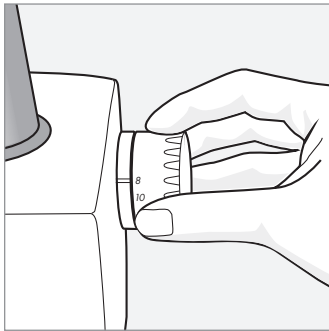

Scale on the knobs
10 and 30

Leica EZ4 with fixed 10x eyepieces

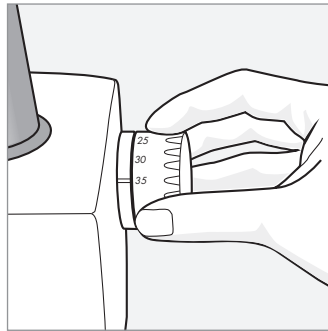

Scale on the knobs
8, 10, 12.5, 16, 20, 25, 30, 35

Leica EZ4 with fixed 16x eyepieces

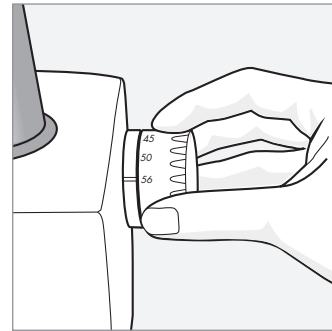

Scale on the knobs
13, 16, 20, 25, 32, 40, 50, 56

Magnification display for Leica EZ4 models with open tubes



On the EZ4 model without eyepieces, only the magnification factors of the magnification changer are indicated: 0.8, 1, 1.25, 1.6, 2, 2.5, 3, 3.5.

Different total magnifications are possible depending on which eyepieces are used with the EZ4 (see Table page 22). The magnification of the eyepieces is indicated on their outer surfaces, e.g. 10x/20, 16x/16 or 20x/12.

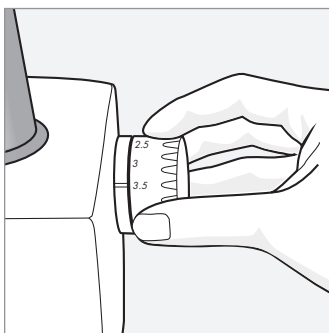

Illumination

i All Leica stereomicroscopes are equipped with an integrated incident and transmitted light illumination: Incident and transmitted light can be switched on separately and also together. After switching off, the LEDs remain lit for about another 4 sec.

Leica ES2 illumination

There is one On/Off switch each for incident and transmitted light.



0 = OFF
I = ON

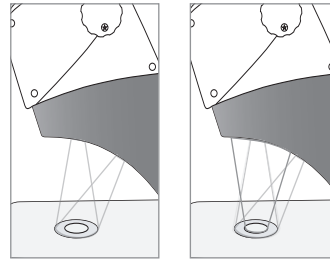

- In incident light, the object is well illuminated from above by 3 LEDs.
- Incident and transmitted light can be combined.
- Unlike the EZ4 models there is no dimmer.

The illumination on Leica EZ4 models

- i**
- The illumination on EZ4 models is more convenient and has more capabilities, such as an easy-to-operate, water- and dust-proof membrane keypad for controlling incident and transmitted light, with 3 incident light variants and a dimmer.
 - The On/Off switch is separate from the light controller and is located on the back of the device.
 - The illumination switches off automatically after an hour. The Auto-Off helps to save the LEDs if someone forgets to switch off the light.

Three-level incident light illumination

The incident light illumination is made up of 5 LEDs. Two, three or 5 diodes are switched on depending on the level. Accordingly, the angle of incidence of the light beam on the object is switched from high to low.

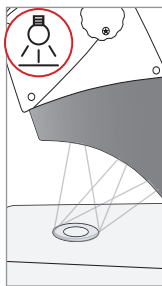
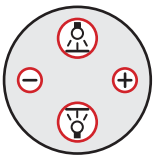

Press once:
Five diodes:
Greatest
brightness for
incident light
objects

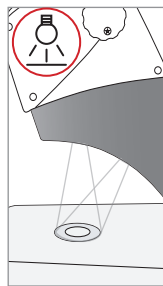

Press twice
Top three diodes:
shadowless
uniform lighting
for objects with
highly uneven
surfaces

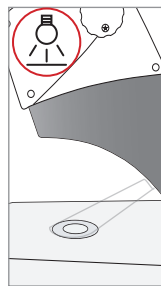

Press three
times
Two diodes:
Spotlight for
emphasizing
the surface
structure and
contrast in flat
objects

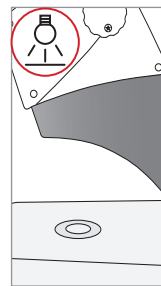

Press four
times
Incident light
off

Dimming



Dimmer for
regulating the
brightness of
incident and
transmitted
light. If incident
and transmitted
light are both
switched on at
the same time,
the brightness
is adjusted
synchronously.

Transmitted light illumination

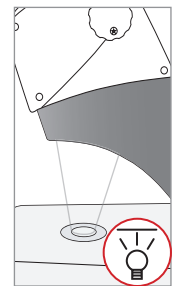

Press once:
Switch on
transmitted light
for transparent
objects and
transmitted light
specimens.

Starting the Leica ES2

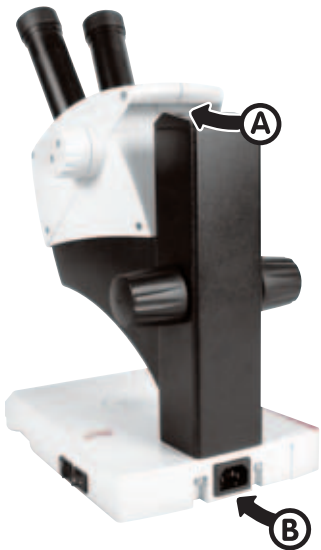

Carrying and setting up

- ▶ Hold and carry the device by the integrated handle (A).
- ▶ Place your other hand under the base to support it.
- ▶ Set the device up on a flat countertop.
- ▶ Connect the mains cable (B)



Setting the eye distance

- ▶ **Working without eyeglasses:**
Open out the eyecups
- ▶ **Working with eyeglasses:**
Fold the eyecups back (A)!
- ▶ **Adjust the eye distance:**
Look through the eyepieces and at the same time push the tube inwards (B) until a single, round object field is visible.

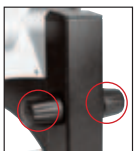

Is the focus movement too loose or too tight? Does the outfit tend to slide downwards? The ease with which the device can be adjusted is itself adjustable: Grasp the drive knobs with both hands and turn them towards each other until the desired resistance is reached for focusing.



Adjust light:

- ▶ Place object (A) and depending on the object switch on incident or transmitted light with the switches on the side of the base (B).

Incident light:

for plastic, opaque objects

Transmitted light:

for transmitted light specimens or transparent objects

Combination:

for partly transparent objects

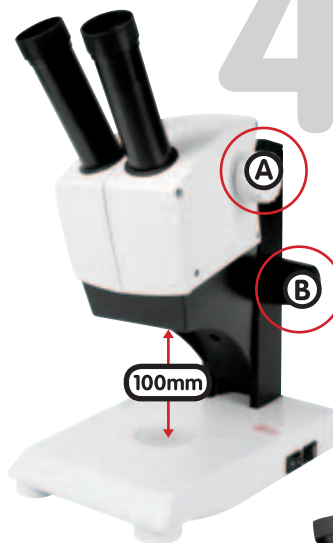

Focussing:

- ▶ Set the magnification changer to the lowest level 10 (A).
- ▶ Use the focussing drive (B) to set the work distance to 100 mm = coarse focus.
- ▶ Set the magnification changer to the second level 30 (A).
- ▶ Use the focus drive again to regulate fine focusing (B).
- ▶ In this way, the sharpness remains constant when changing between magnification levels (parfocal). See below for instructions on setting the ease of movement of the focusing drive.



Pack the device away

- ▶ Switch the light off after use.
- ▶ Roll up the cable as shown.
- ▶ Pick the device up by the handle to move it.
- ▶ Protect from dust when storing.

Starting the Leica EZ4

i If the illumination is not operated for 60 minutes, on the EZ4 models it switches off automatically. The illumination can be reactivated by pressing a button on the membrane keypad.



Carrying and setting up

- ▶ Hold and carry the device by the integrated handle (A).
- ▶ Place your other hand under the base to support it.
- ▶ Place on a flat work surface, connect the mains cable (B) and switch on (C).

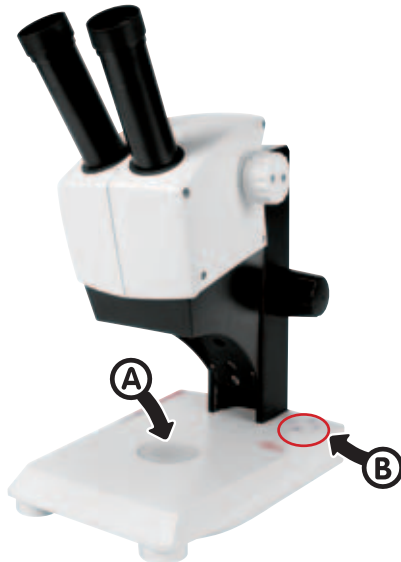

Switching on the light:

- ▶ Position the object (A).
- ▶ Depending on the object, switch on incident light or transmitted light (B).
- ▶ A detailed description of the illumination is on page 7.

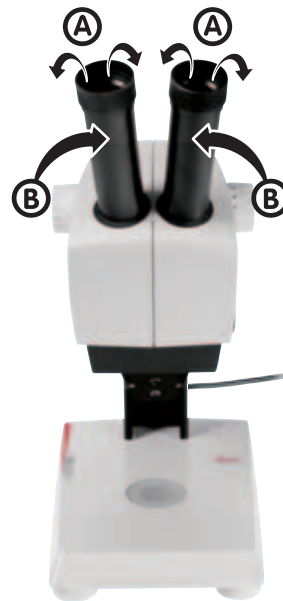

Setting the eye distance

- ▶ **Working without eyeglasses:** Open out the eyecups
- ▶ **Working with eyeglasses:** Fold the eyecups in! (A)
- ▶ **Setting the eye distance:** Look through the eyepieces and at the same time push the tubes inwards (B), until a single, round object field is visible.

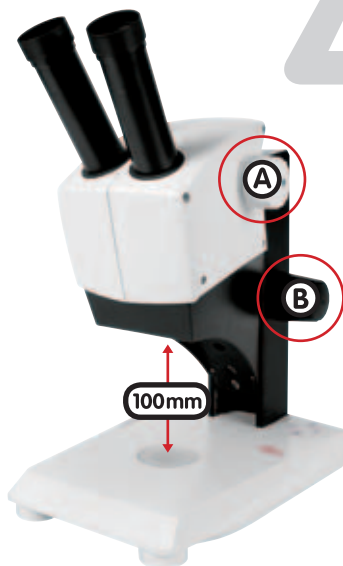

Focussing:

- ▶ Set the magnification changer to the lowest magnification (A).
- ▶ Use the focussing drive (B) to set the work distance to 100 mm = coarse focus.
- ▶ Set the zoom to the highest magnification (A).
- ▶ Use the focusing drive again to adjust fine focusing (B).
- ▶ In this way, the focus will remain constant throughout the entire zoom range (=parfocal).

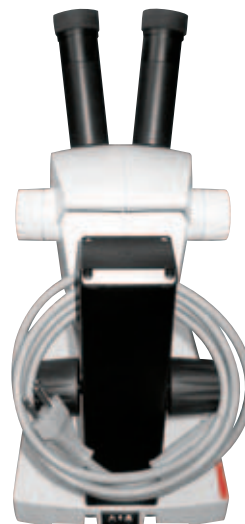

Packing the device away

- ▶ After use, roll up the cable as shown.
- ▶ Pick the device up by the handle to move it.
- ▶ Protect from dust when storing.

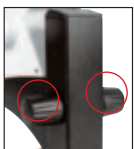

i

Is the focus movement too loose or too tight? Does the outfit tend to slide downwards? The ease with which the device can be adjusted is itself adjustable: Grasp the drive knobs with both hands and turn them towards each other until the desired resistance is reached for focusing.

Leica EZ4 with open tubes



For replaceable eyepieces.

The basic settings are the same as for the EZ4 models with fixed eyepieces (see page 9).

For diopter settings with adjustable eyepieces, see page 11



- Eyepieces replaceable, fixed or adjustable: 10x/20, 16x/16 or 20x/12
- Eyepieces for eyeglass wearers 10x/20B and 16x/15B, fixed and adjustable
- Diopters can be regulated from +5 to -5 (adjustable eyepieces)
- Use of measuring graticules possible (adjustable eyepieces), see pages 12-13
- Leica DC150 digital camera with adapter can be used

Adjustable eyepieces for eyeglasses with straight eyecups.

Eyepieces: Examples



Eyeglass eyepiece with adjustable diopter and straight eyecup.



Eyepiece for users who do not wear eyeglasses with adjustable diopter and inclined eyecup



Fixed eyepiece with inclined eyecup.



The eyecups can be replaced.

Direct contact with eyecups can be a potential transmission path for bacterial and viral infections of the eye. Users should be made aware of the potential risk of infection.

The risk can be minimized by the use of individual eyecups.

Diopter settings with adjustable eyepieces

General notes



- Only with the Leica EZ4 with freely selectable, adjustable eyepieces.
- For adjusting the diopter for impaired vision and for measuring with graticules. Users with normal vision do not need adjustable eyepieces! An adjustable eyepiece is sufficient for mild shortsightedness!
- If vision is extremely poor or when graticules are used, two adjustable eyepieces are needed.
- When the diopters are regulated exactly, the sharpness is constant over the entire magnification range (=parfocal)!
- Once the diopters have been set, the procedure does not have to be repeated. Simply set the diopter values found on the eyepiece before beginning work with the stereomicroscope

Setting the diopters with one adjustable and one fixed eyepiece

Preparation:

- ➔ Place a flat test object on the stage insert.
- ➔ Set the eye distance and illumination.
- ➔ Set the lowest magnification.
- ➔ Set the adjustable eyepiece to 0.
- ➔ Use the focusing drive to set the eye distance to about 100 mm.

Setting the diopter on the adjustable eyepiece

3



- ▶ Without looking into the eyepieces, turn the lens on the eyepiece as far as it will go in the + direction.

- ▶ Close the eye above the fixed eyepiece.

- ▶ Look into the adjustable eyepiece with the other eye.

- ▶ Slowly turn the lens towards the "-" until the test object is sharply in focus.



Do not turn back and forth, otherwise the eye will adapt. In this case, relax the eye and repeat the setting procedure.

Focusing on the test object

2

- ▶ Close the eye that is above the adjustable eyepiece.
- ▶ Look into the fixed eyepiece with the other eye.
- ▶ Look at the test object and use the focusing drive to bring it into focus.



Fine focusing

4

- ▶ Set the highest magnification.
- ▶ View the object with both eyes.
- ▶ Optimize sharpness with the focusing drive.

Now the sharpness should remain constant when zooming from the lowest to the highest magnification. If it does not, repeat the procedure.



Settings for two adjustable eyepieces

 See also general information on page 10.

Preparation:

- 1
- Place a flat test object under the objective.
 - Set the eye distance and illumination.
 - Set the lowest magnification.
 - Set both eyepieces to 0.
 - Use the focusing drive to set the eye distance to about 100 mm.

2



Prepare for focusing

- Look into both eyepieces and focus the test object.
- Set the highest magnification.
- Optimize focusing.
- Back to the lowest magnification.

Focus on the test object



3

- Do not look into the eyepieces!
- ▶ Rotate the eyepieces counterclockwise as far as they will go towards the "+".

Setting the diopter on the adjustable eyepieces

4



- ▶ Do not look into the eyepieces. Adjust each eyepiece separately as follows:
- ▶ Close one eye. With the other eye, view the test object and slowly rotate the lens clockwise, in the "-" direction until the object appears in focus to that eye.
- ▶ Adjust the diopter for the other eye in the same way.

 Do not rotate back and forth, because otherwise the eye will adapt. Instead, relax the eye and start the adjustment procedure again.

Fine focusing

5



- ▶ Select the highest magnification.
- ▶ Look at the object, and gently adjust the focus if necessary.
- ▶ Slowly move the magnification changer from the lowest magnification to the highest.

 The sharpness should be constant for the entire zoom range (parfocal). Otherwise, repeat the procedure.

Graticules

i The graticules can only be inserted in adjustable eyepieces. The transparent graticules, which are insertable in the adjustable eyepieces, enable simple measurements to be made of objects that are being observed under the stereomicroscope. The following graticules and objective micrometers for calibrating may be ordered:

Graticules:	10 mm / 0.1 mm	Objective micrometers:	50 mm	0.1 / 0.01 mm increment
	5 mm / 0.1 mm		1"	0.001" increment
	5 mm / 0.05 mm	Crosshairs		
	100 Div / 0.002"			
	100 Div / 0.001"			
	150 Div / 0.0005"			

i For equipment with a graticule in one eyepiece, two adjustable eyepieces are needed. Since one eye is focussed on the eyepiece with the graticule, it needs a second, adjustable eyepiece so that it can be aligned optically with the first.

Inserting the graticule in the adjustable eyepieces

i The graticule must always be clean and dust-free! Never touch the graticule with bare hands! Always hold the graticule by the edges! Measuring, focusing with the graticule and cleaning are all described in the "Measuring" instructions for use.

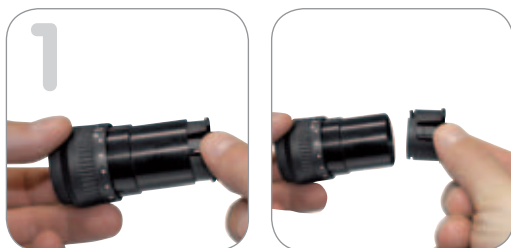

The 10x and 20x adjustable eyepieces include an insert at the bottom with a snap-lock.

- ▶ Press the two small clips on the snap-lock together gently and take out the insert.



On the 16x eyepieces, the insert is fixed to the eyepiece by a screwed connection.

- ▶ Twist the insert counterclockwise to take it out.

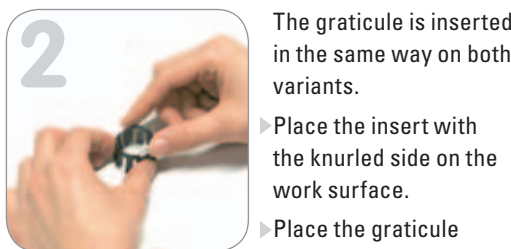

The graticule is inserted in the same way on both variants.

- ▶ Place the insert with the knurled side on the work surface.
- ▶ Place the graticule ready with the scale on the right side!



- ▶ Place the insert back in the eyepiece and either press or twist into place depending on the variant.



- ▶ Insert the eyepiece in the tube.
- ▶ Align the graticule by rotating the eyepiece in the tube.

the right side! (can be determined with the aid of the stereomicroscope).

- ▶ Carefully take hold of the edge of the graticule and push it into the holder in the insert.
- ▶ Click both plastic holders into place.

i For instructions on focusing and correcting the diopter, with a graticule, see the "Measuring" instructions for use.

Photographing with the Leica DC150 digital camera



The Leica DC150 digital camera can ONLY be attached to the Leica EZ4 with open tubes; in this way, photographs can be taken through the tube. First insert the battery and memory card. For instructions on installing the software and using the camera see the instructions for use for the DC150 digital camera.



- 1
- ▶ Push the spacer ring into the neck (this ensures the correct and parfocal camera distance).



- 2
- ▶ Tighten the clamping screw slightly, so that the spacer ring does not fall out.



- 3
- ▶ Switch the camera on manually by opening the lens cover.
 - ▶ The lens extends.



- 4
- ▶ Place the adapter on a table to keep it safe.
 - ▶ Dock the camera on the adapter as shown.
 - ▶ Secure the camera by tightening the screw that is integrated with the adapter.



- 5
- ▶ Insert the camera and adapter as far as possible into the tube of the stereomicroscope.
 - ▶ Ensure that it is firmly in place.
 - ▶ If necessary, loosen the clamping screw slightly until the adapter can be pushed all the way in.
 - ▶ Otherwise, the focal plane will not be correct.
 - ▶ Tighten the clamping screw.

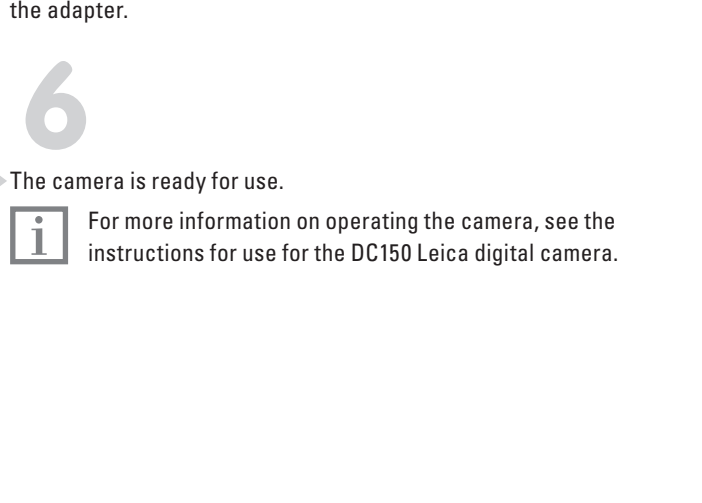

- 6
- ▶ The camera is ready for use.



For more information on operating the camera, see the instructions for use for the DC150 Leica digital camera.

Leica EZ4 D device overview

 Do not insert anything except the SD card in the card slot – danger of short circuit and electric shock!

Scope of delivery for the EZ4 D

- Complete stereomicroscope with fixed 10x eyepieces and integrated 3.0 megapixel CMOS camera (see also page 5)
- CD ROM with software for controlling and image editing
- USB cable
- Cable for connection to an video projector
- SD memory card

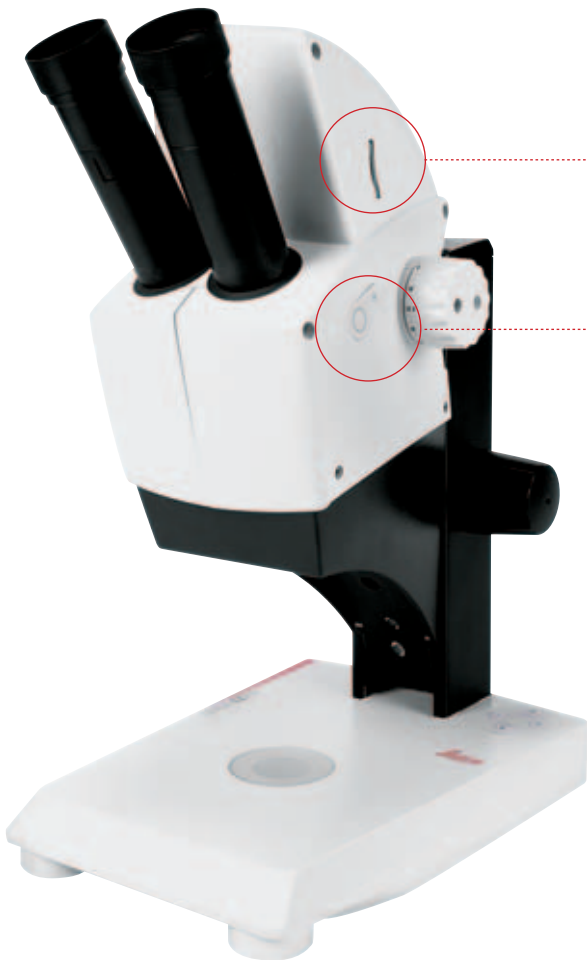

Card slot with SD memory card

Press the card lightly with the finger to insert it; press again and the card is ejected automatically.

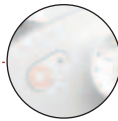

Image capture button with LED

With the image capture button, the photograph can be taken directly at the device.

The LED changes to green as soon as the card is inserted or the device is connected to a PC/Mac.

When the picture capture button is pressed, the LED flashes green while the picture is being captured.

When the picture capture is complete, a clicking noise is heard. The camera is ready to take another picture.

- | | |
|---------------------|-------------------------------|
| LED Green: | • Ready to take a picture |
| LED Green flashing: | • Capturing an image |
| LED Red: | • Not ready for use <i>or</i> |
| | • Connect device <i>or</i> |
| | • Insert SD card |

Connector port (back of the device)

The power socket is intended for use in the future.  At the moment, no devices must be connected here.

Connection to video projector/video

Switching (with ballpoint pen) between PAL (Europe) and NTSC (United States, Canada)

Connection to PC/Mac



Photographing with the Leica EZ4 D: Four different modes of use

i General notes

- For instructions on installing and using the accompanying software, see the CD ROM, which is also supplied.
- As soon as the EZ4 D is connected to a power cable and the mains switch is turned on, the integrated camera is also ready for use.
- If a USB cable is not connected and there is no SD card in the card slot for the EZ4 D, the LED on the picture capture button lights up RED.
- Fixed 10x eyepieces have a fixed a field of view of 20 mm, while the field of view of the cameras is 14. As a result, the image field of the camera is smaller than the object field through the eyepiece.



1

Direct capture of pictures without connection to a PC:

- ▶ Insert the SD card, the LED changes color to GREEN. The camera is ready to take pictures.
- ▶ Take a picture: Press the release button, the LED will flash GREEN during capture.
- ▶ Upload the photos to a PC or Mac using a card reader.

2

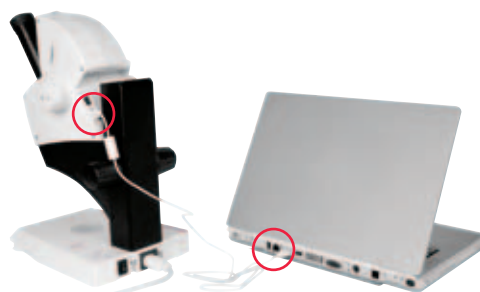

Connection to a PC or MAC via the USB 2.0 cable:

For a separate description of connecting to a computer and installing the software, see the accompanying CD ROM. The software must be installed before the device is connected for the first time!

i If the device is connected to a computer, pictures cannot be taken with the SD card.

3



Connection to an analog video output:

The EZ4 D can be connected to a range of different devices with analog video input (video recorder, video projector...) via an analog video output (composite).

Picture capture as for card capture point 1.

It is possible to switch between PAL and NTSC formats.



Use the tip of a ballpoint pen to press the small button at the back beside the ports.: Switches between PAL (Europe) and NTSC (United States, Canada)

4



Connection to a PC or MAC via the USB 2.0 cable plus video projector:

For a separate description of connecting to the computer and installing the software, see the accompanying CD ROM.

i The picture cannot be seen through the video projector until the Live-Image appears on the PC monitor.

Care and maintenance

Dust and dirt will affect the quality of your results.

- Cover with the dust protection cover during breaks.
- Cover open tubes and eyepieces with dust caps.
- Remove dust with a pneumatic rubber bulb and a soft brush.
- Use only special optical cloths and pure alcohol to clean the eyepieces.
- Protect unused accessories from dust generally when they are not in use.

Incorrect cleaning can damage the plastic parts!

- Never use ultrasonic equipment to clean! The polymer can become brittle and later break.
- Never use corrosive and/or acetone-based agents such as ether substitute.
- If solvents must be used, only ethanol and isopropanol are acceptable.
Take note of the safety instructions on the manufacturer's packaging!
- Soapy water, distilled water, recommended solvents and pure alcohol can safely be used to clean the device.

General protective measures (see also General Notes, page 3)

- Protect instrument from moisture, vapors, acids and alkalis. Do not store chemicals close to the device.
- Safeguard the instrument against incorrect handling: Never connect plugs from other devices or disassemble the optical system and mechanical parts.
- Do not grease guide surfaces or mechanical parts.



Technical Data: Stereomicroscope

	Leica ES2	Leica EZ4 10x	Leica EZ4 16x	Leica EZ4 Open	Leica EZ4 D 10x
Stereomicroscope					
Microscope type	Stereomicroscope	Stereomicroscope	Stereomicroscope	Stereomicroscope	Stereomicroscope
Optical system	10°-Greenough, parfocal	10°-Greenough, parfocal	10°-Greenough, parfocal	10°-Greenough, parfocal	10°-Greenough, parfocal
Magnification changer	2-level, 3:1	4.4:1 zoom	4.4:1 zoom	4.4:1 zoom	4.4:1 zoom
Eyecups for eyeglass wearers	10x/20 fixed	10x/20 fixed	16x/15 fixed	replaceable, fixed or adjustable: 10x/20, 16x/16, 20x/12	10x/20 fixed
Diopter correction				From +5 to -5 (adjustable eyepieces)	
Viewing angle	60°	60°	60°	60°	60°
Working distance	100 mm	100 mm	100 mm	100 mm	100 mm
Magnification range	10x/30x	8x to 35x	12.8x to 56x	Depending on the eyepiece used: 8x to 70x	8x to 35x
Maximum resolution	159 Lp/mm	170 Lp/mm	170 Lp/mm	170 Lp/mm	170 Lp/mm
Maximum numerical aperture	0.053 nA	0.057 nA	0.057 nA	0.057 nA	0.057 nA
Object field diameter	20 mm/6.7 mm	5.7 to 25 mm	4.3 to 18.8 mm	Depending on the eyepiece used: 3.4 to 25 mm	5.7 to 25 mm
Eyecups	replaceable	replaceable	replaceable	replaceable	replaceable
Interpupillary distance	50 to 75 mm	50 to 75 mm	50 to 75 mm	50 to 75 mm	50 to 75 mm
Beam path	100% visual	100% visual	100% visual	100% visual	50% visual 50% video/photo
Focusing drive	Ease of motion individually adjustable	Ease of motion individually adjustable	Ease of motion individually adjustable	Ease of motion individually adjustable	Ease of motion individually adjustable
Carrying handle	integrated, travel 75 mm	integrated, travel 75 mm	integrated, travel 75 mm	integrated, travel 75 mm	integrated, travel 75 mm

Technical data: Illumination system

	Leica ES2	Leica EZ4 10x	Leica EZ4 16x	Leica EZ4 Open	Leica EZ4 D 10x
Illumination system					
LED incident light/ transmitted light illumination	Integrated, can be activated separately or together	Integrated, can be activated and regulated separately or together	Integrated, can be activated and regulated separately or together	Integrated, can be activated and regulated separately or together	Integrated, can be activated and regulated separately or together
Controller	On/Off switch	Membrane keypad	Membrane keypad	Membrane keypad	Membrane keypad
Incident lighting method	Oblique incident light with 3 LEDs	Choice of 3 methods available: Maximum brightness with 5 LEDs, oblique incident light with 3 LEDs, flat spotlight with 2 LEDs (patent applied for)	Choice of 3 methods available: Maximum brightness with 5 LEDs, oblique incident light with 3 LEDs, flat spotlight with 2 LEDs (patent applied for)	Choice of 3 methods available: Maximum brightness with 5 LEDs, oblique incident light with 3 LEDs, flat spotlight with 2 LEDs (patent applied for)	Choice of 3 methods available: Maximum brightness with 5 LEDs, oblique incident light with 3 LEDs, flat spotlight with 2 LEDs (patent applied for)
Dimmer		Yes, for incident and transmitted light	Yes, for incident and transmitted light	Yes, for incident and transmitted light	Yes, for incident and transmitted light
Auto OFF		After 60 minutes	After 60 minutes	After 60 minutes	After 60 minutes
Service life of the LEDs	Approx. 25 000 hours	Approx. 25 000 hours	Approx. 25 000 hours	Approx. 25 000 hours	Approx. 25 000 hours
Light quality	Homogenous daylight, UV, IR radiation-free	Homogenous daylight, UV, IR radiation-free	Homogenous daylight, UV, IR radiation-free	Homogenous daylight, UV, IR radiation-free	Homogenous daylight, UV, IR radiation-free
Maintenance	No maintenance required	No maintenance required	No maintenance required	No maintenance required	No maintenance required
Power supply	100 V – 240 V AC 15 W 50/60 Hz	100 V – 240 V AC 15 W 50/60 Hz	100 V – 240 V AC 15 W 50/60 Hz	100 V – 240 V AC 15 W 50/60 Hz	100 V – 240 V AC 30 W 50/60 Hz

Technical data: Digital camera and accessories

	Leica ES2	Leica EZ4 10x	Leica EZ4 16x	Leica EZ4 D Open	Leica EZ4 D 10x
Digital camera					
Digital camera				7.1 Mpixel Leica DC150 with adapter (optional accessory)	Integrated 3.0 Mega Pixel CMOS camera
Output					USB2.0
Analog video output					RCA, Video, Composite for projector, TV monitor, video recorder
Integrated slot					for 128 MB SD (Secure Digital) card
Photo					Integrated switch for picture capture
Software					FOC Software for PC and MAC

	Leica ES2	Leica EZ4 10x	Leica EZ4 16x	Leica EZ4 Open	Leica EZ4 D 10x
Accessories					
Digital camera Leica DC150				Can be inserted in an open tube	
Measurement graticules				to be inserted in adjustable eyepieces for length measurements	

Environmental conditions

Environmental conditions during operation:	
Ambient temperature	+10 °C to +40 °C
Rel. humidity	up to 35 °C ambient temperature: 75%
Air pressure	700 ... 1060 hPa
Storage temperature	-20 °C - +55 °C

Transport and storage:	
Temperature	-20 °C ... +52 °C
Rel. humidity	10 ... 95% (non-condensing)
Air pressure	500 ... 1200 hPa
Norms	CE Communautés Européennes CSA Canadian Standards Association (USA, Canada)

Weights:

Order number	Device	Net weight	Device dimensions
10447202	Leica ES2 with 10x eyepieces	3.82 kg	180 x 255 x 365
10447197	Leica EZ4 with 10x eyepieces	3.8 kg	180 x 255 x 355
10447198	Leica EZ4 with 16x eyepieces	3.8 kg	180 x 255 x 355
10447199	Leica EZ4 with no eyepieces	3.64 kg	180 x 255 x 355
10447200	Leica EZ4 D with 10x eyepieces	4.17 kg	180 x 255 x 363
	Replaceable eyepieces for EZ4 without eyepieces		
10447281	Eyepiece 10x/20, fixed	0.07 kg	
10447282	Eyepiece 10x/20, adjustable	0.08 kg	
10447132	Eyepiece 16x/16, fixed	0.12 kg	
10447133	Eyepiece 16x/16, adjustable	0.13 kg	
10447134	Eyepiece 20x/12, fixed	0.12 kg	
10447135	Eyepiece 20x/12, adjustable	0.13 kg	

Optical data:

Leica ES2 with 10x eyepieces Working distance 100 mm

Eyepieces	Total magnification (Position of the magnification changer)	Object field diameter mm
10x/20	10x	20
	30x	6.7

Leica EZ4 and EZ4 D with 10x eyepieces Working distance 100 mm

Eyepieces	Total magnification (Position of the magnification changer)	Object field diameter mm
10x/20	8x	25
	10x	20
	12.5x	16
	16x	12.5
	20x	10
	25x	8
	30x	6.7
	35x	5.7

Leica EZ4 with 16x eyepieces Working distance 100 mm

Eyepieces	Total magnification (Position of the magnification changer)	Object field diameter mm
16x/15	13x	18.8
	16x	15
	20x	12
	25x	9.4
	32x	7.5
	40x	6
	50x	5
	56x	4.3

Leica EZ4 with open tubes Working distance 100 mm

Eyepieces	Position of the magnification changer	Total magnification	Object field diameter mm
10x/20	0.8	8x	25
	1	10x	20
	1.25	12.5x	16
	1.6	16x	12.5
	2	20x	10
	2.5	25x	8
	3	30x	6.7
	3.5	35x	5.7
16x/16	0.8	12.8x	20
	1	16x	16
	1.25	20x	12,8
	1.6	25.6x	10
	2	32x	8
	2.5	40x	6,4
	3	48x	5,3
	3.5	56x	4,6
20x/12	0.8	16x	15
	1	20x	12
	1.25	25x	9,6
	1.6	32x	7,5
	2	40x	6
	2.5	50x	4,8
	3	60x	4
	3.5	70x	3,4

Dimensions of ES2 with fixed 10x eyepieces
(in mm)

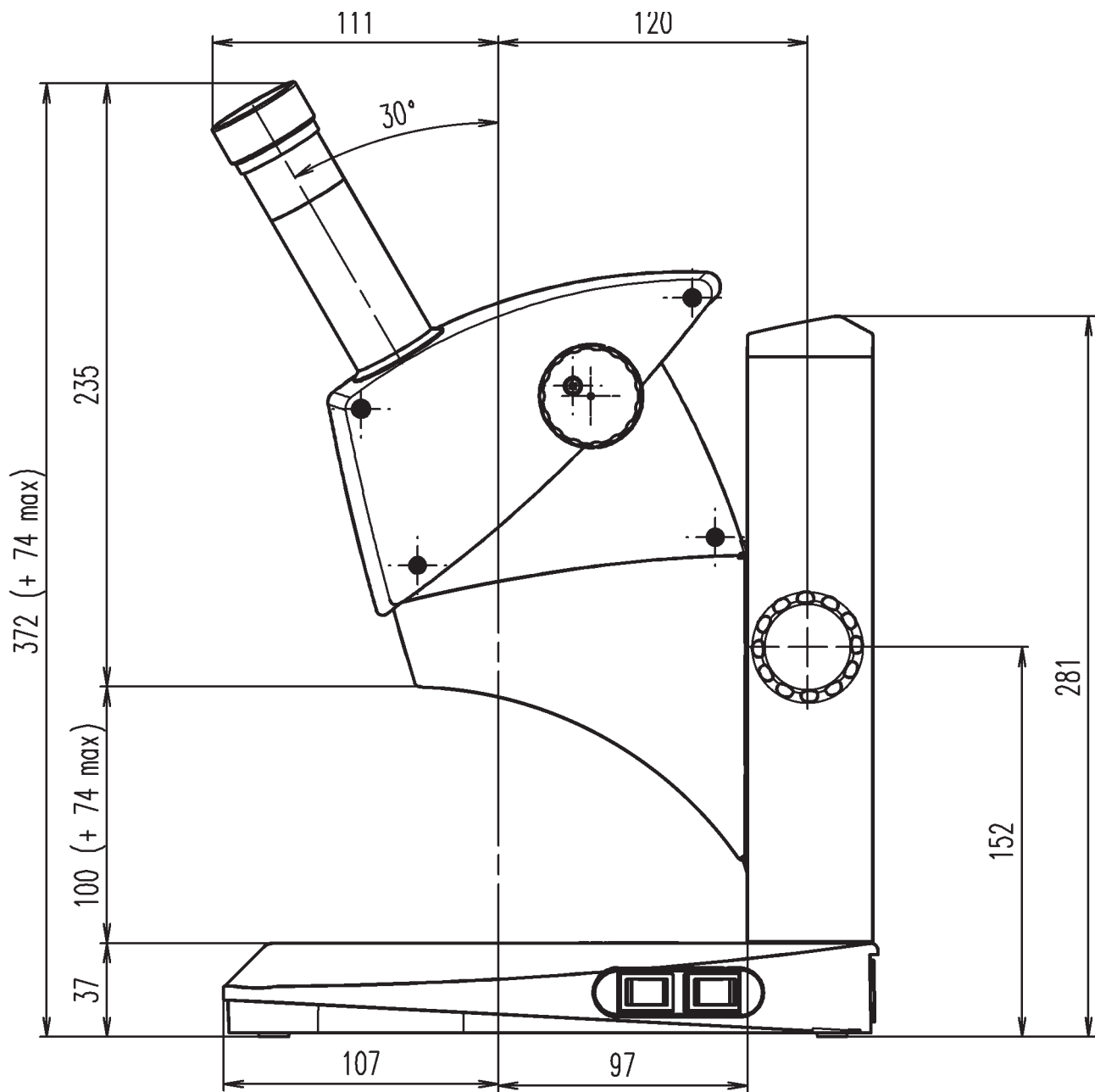

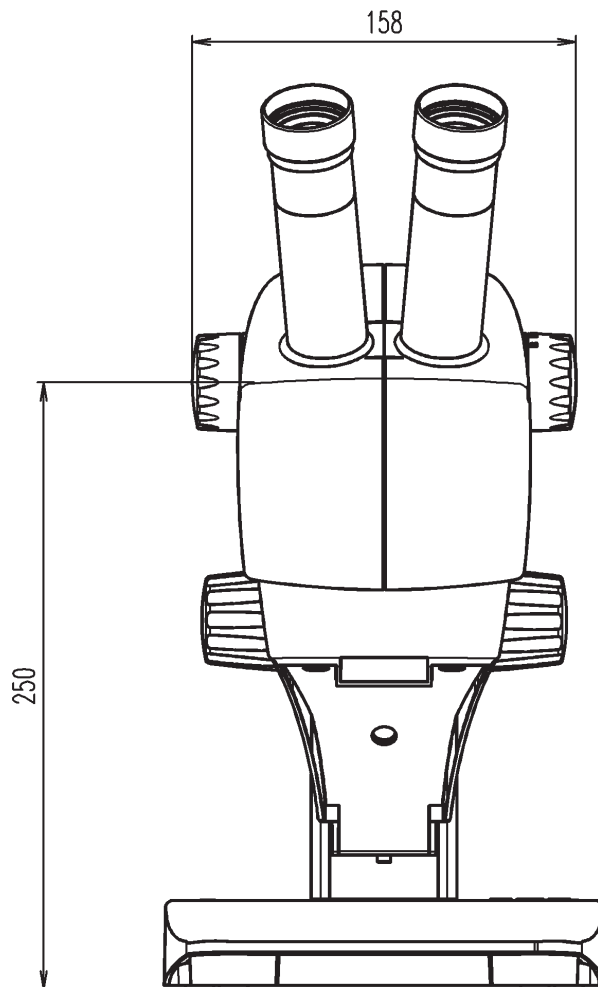
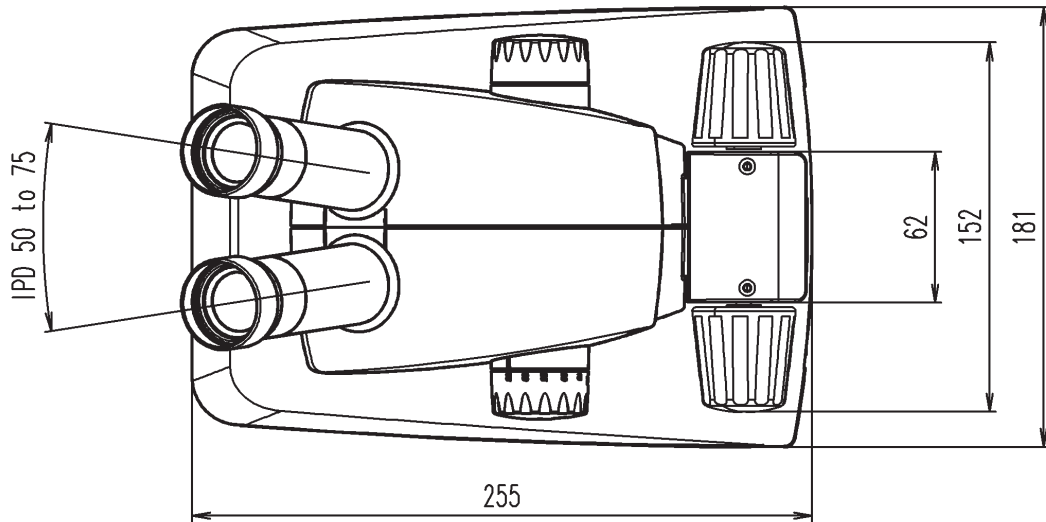

Dimensions of the EZ4 with 10x eyepieces
(in mm)

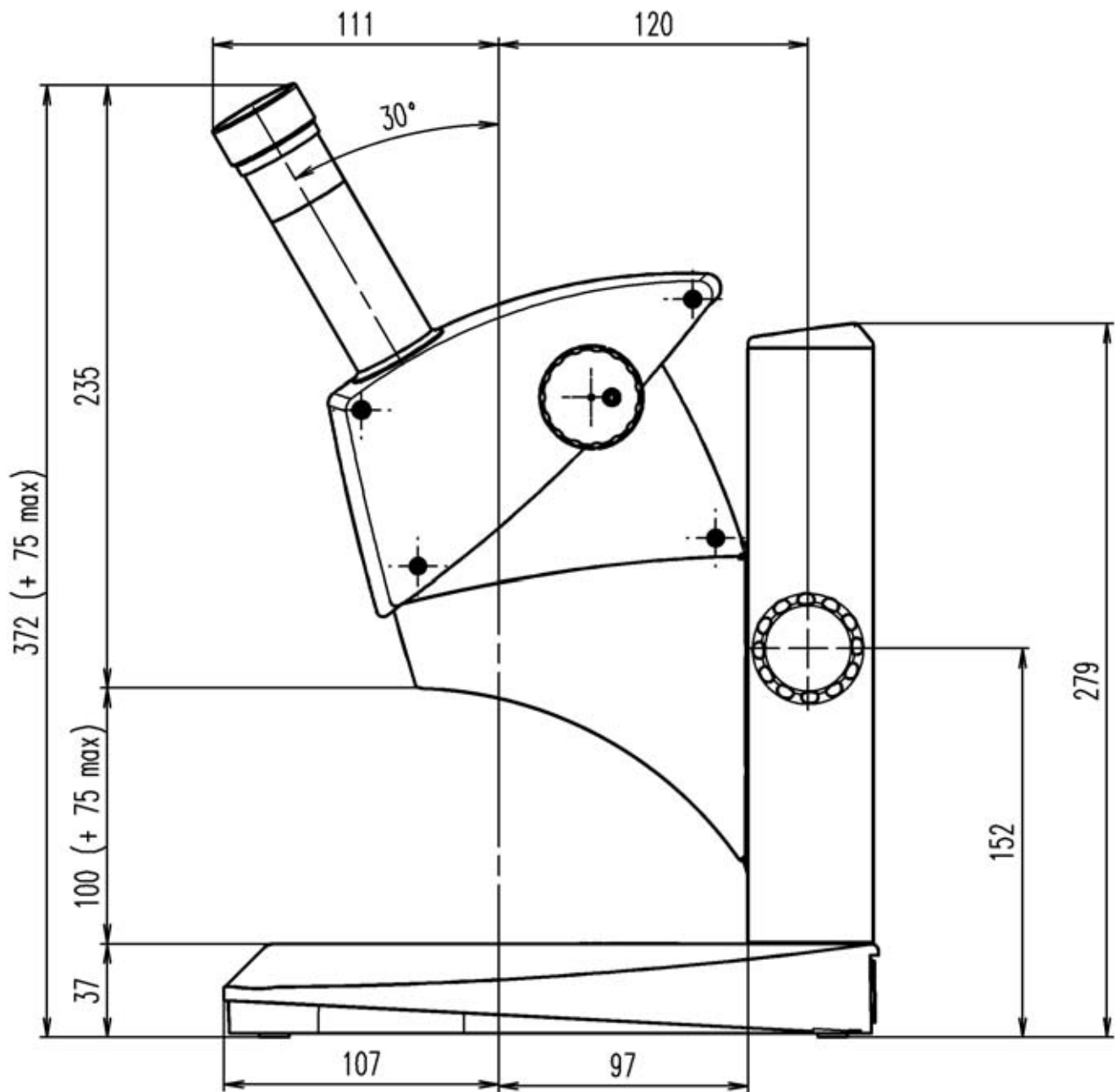

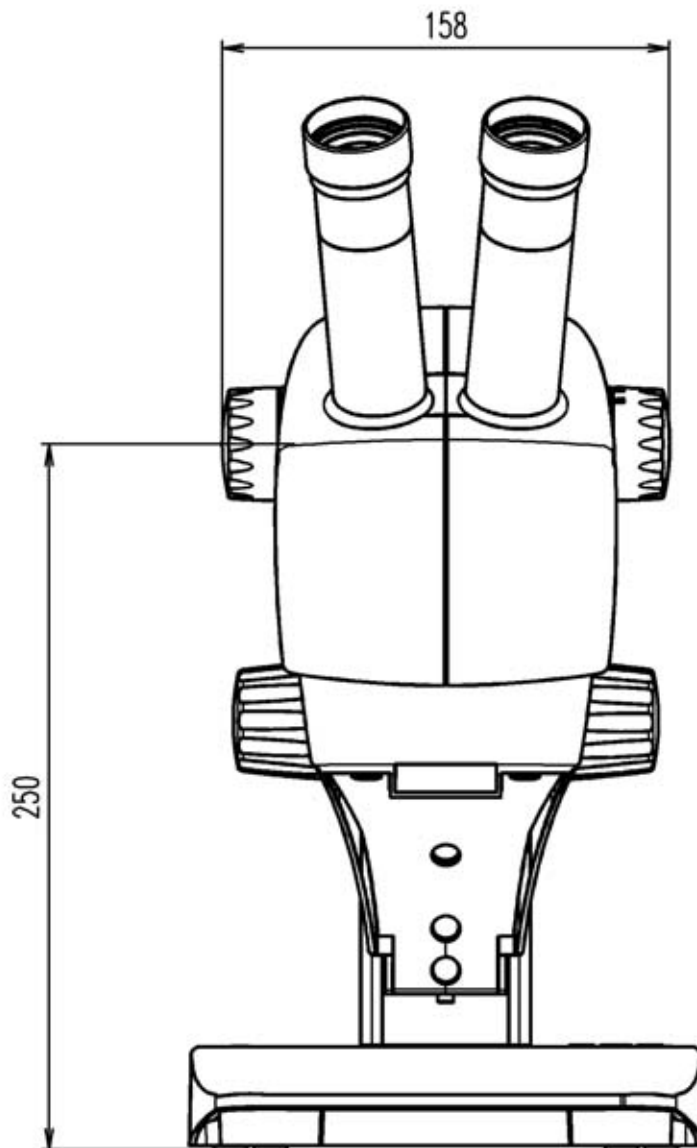
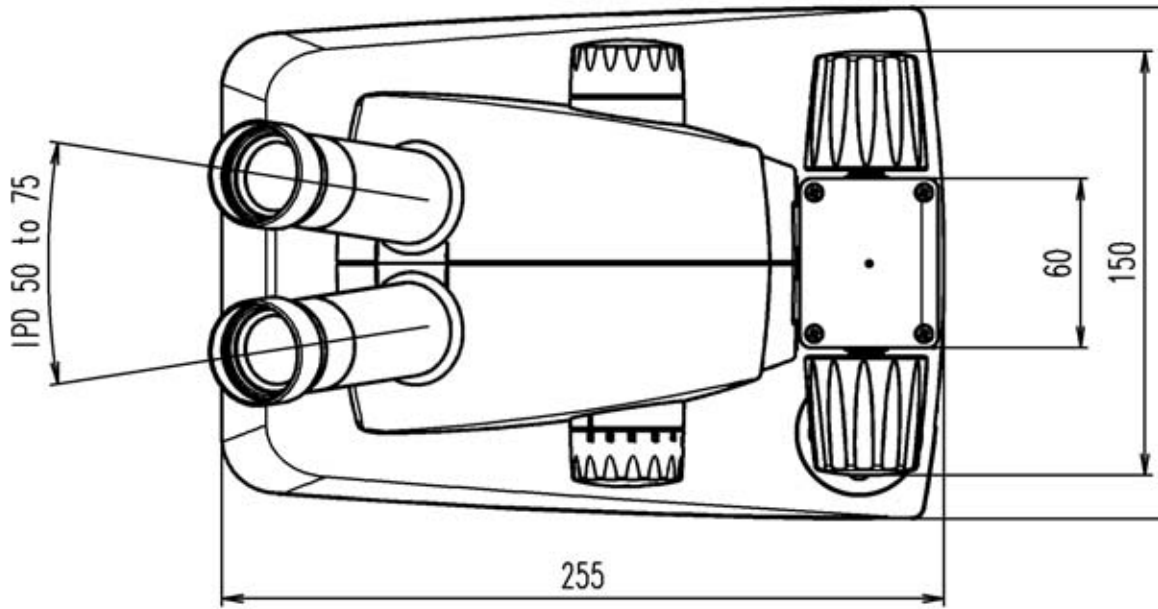

Dimensions of the EZ4 with 16x eyepieces
(in mm)

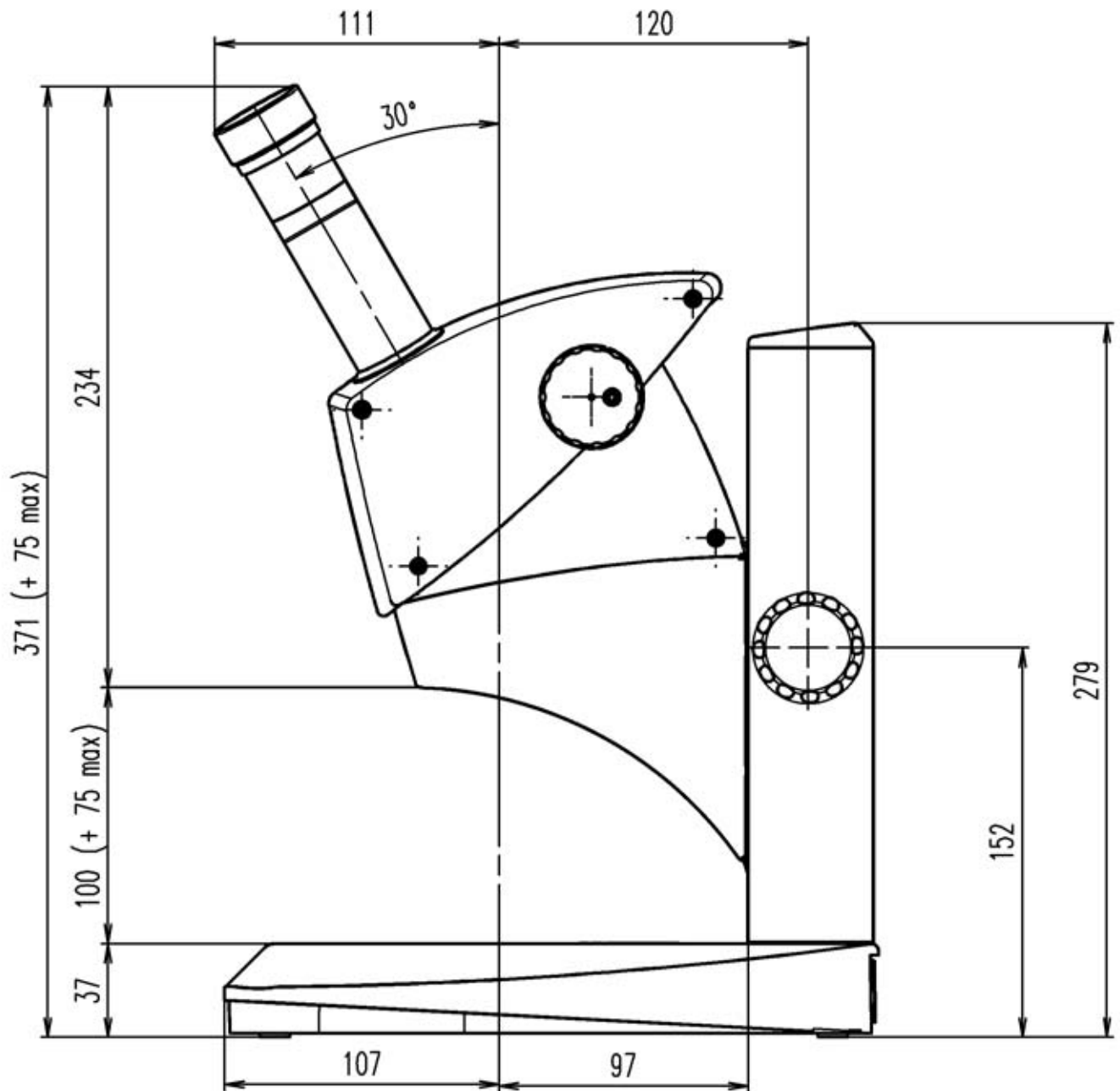

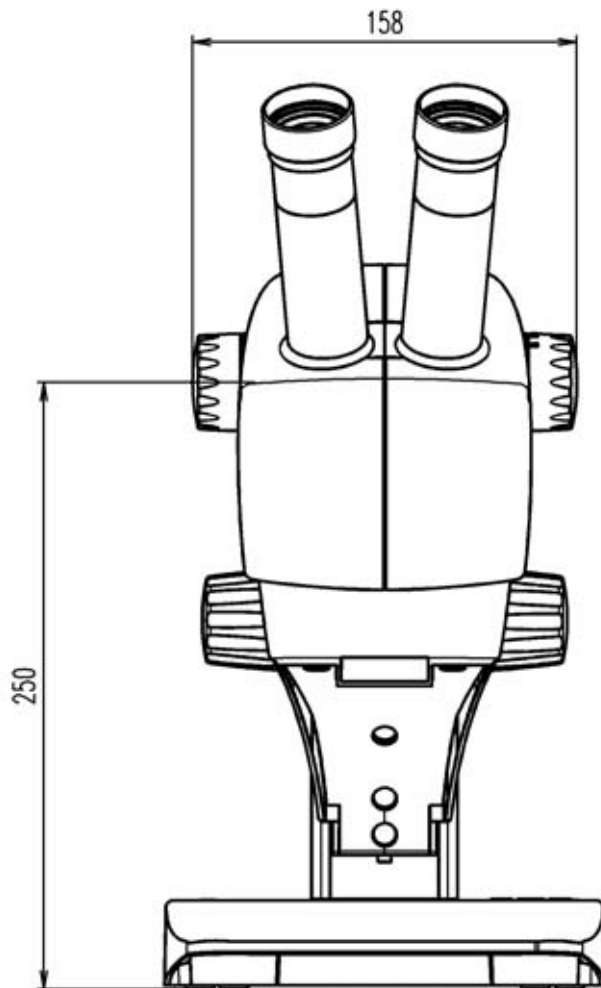
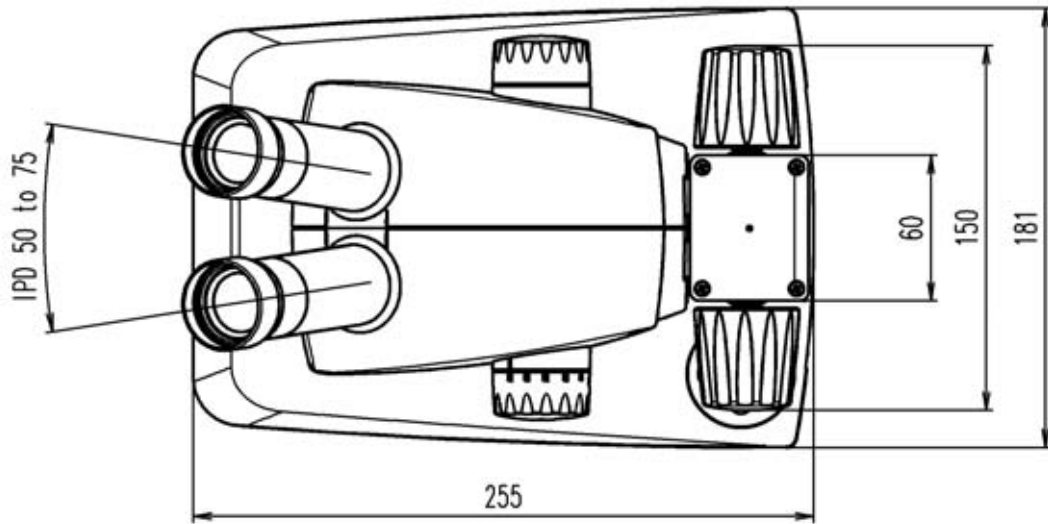

Dimensions of the EZ4 with open tubes (in mm)

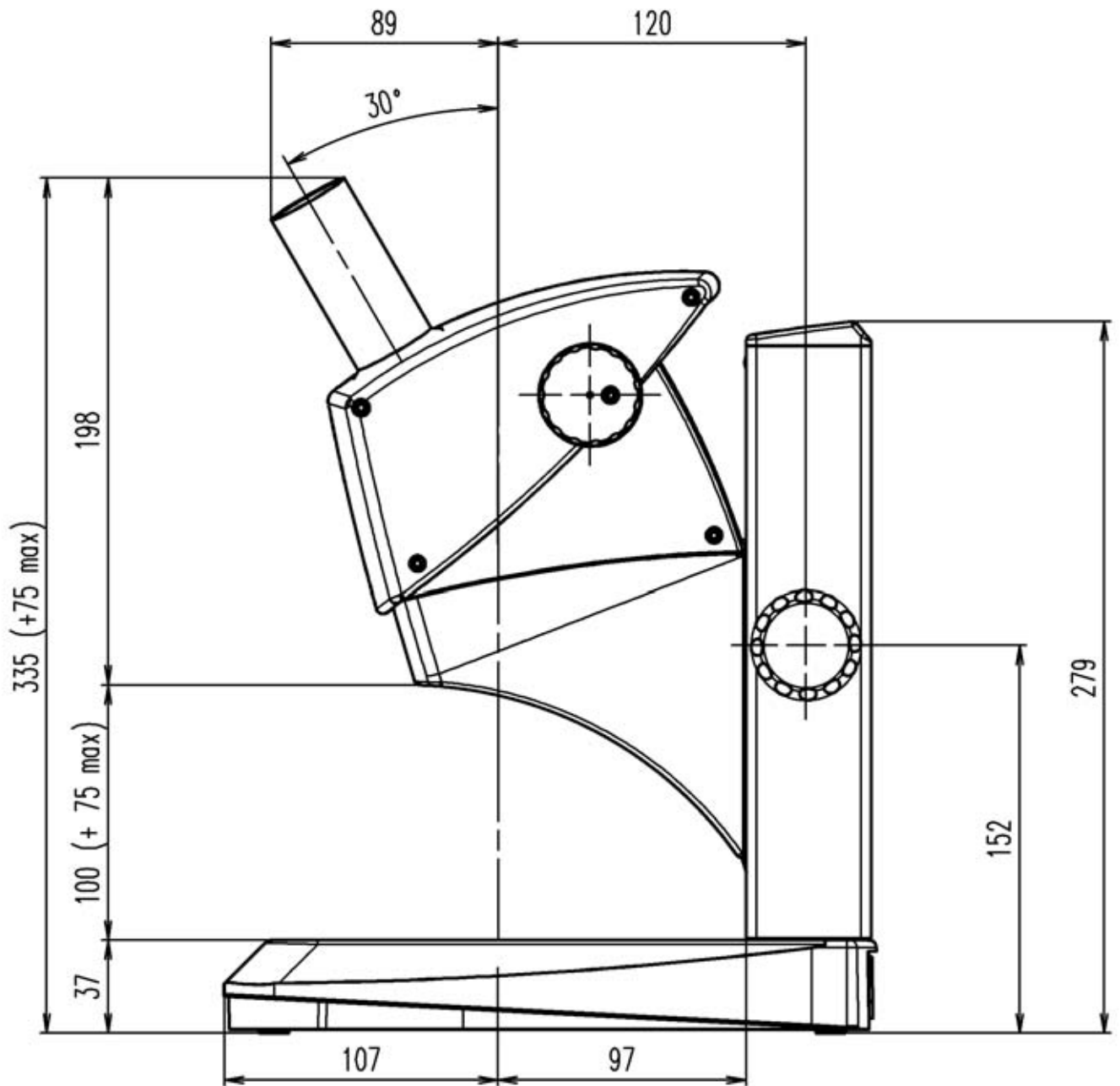

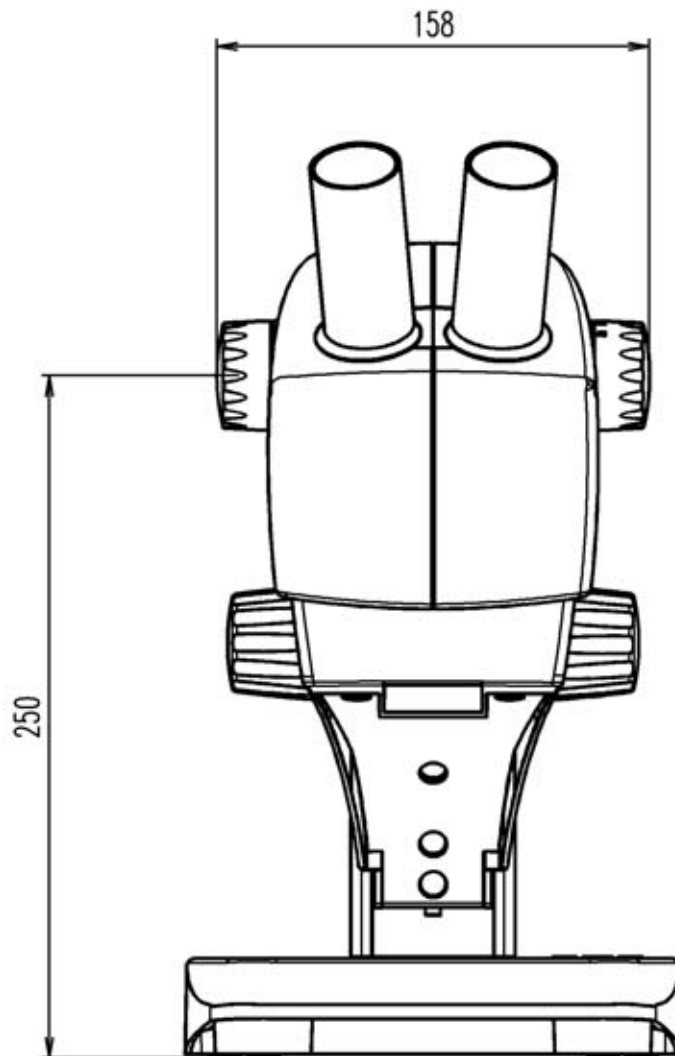
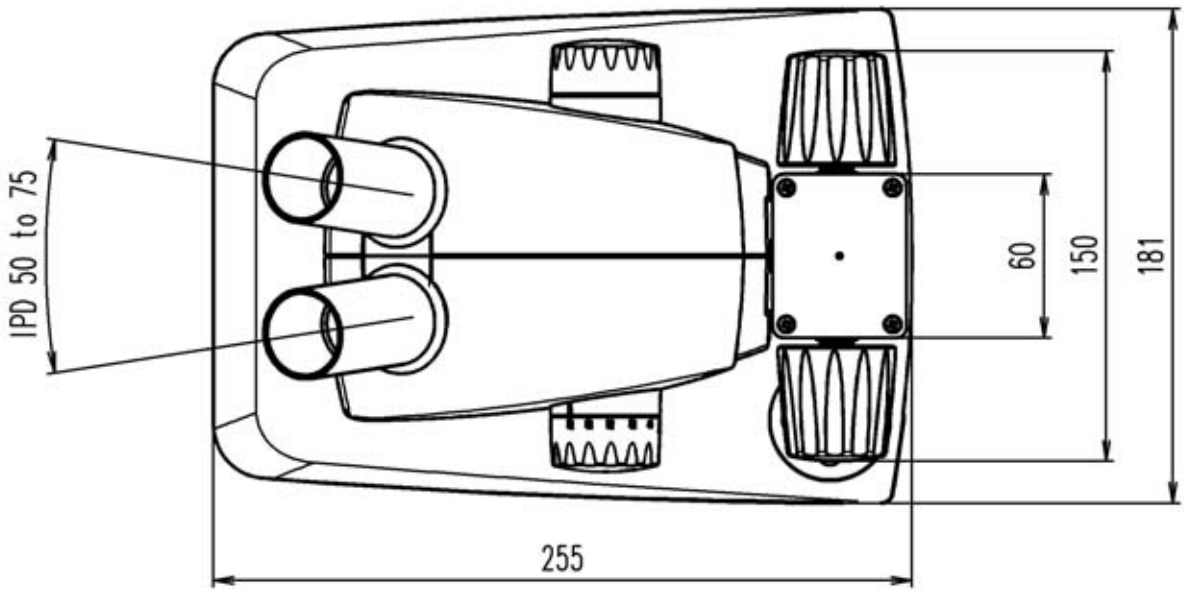

Dimensions of the EZ4 D (in mm)

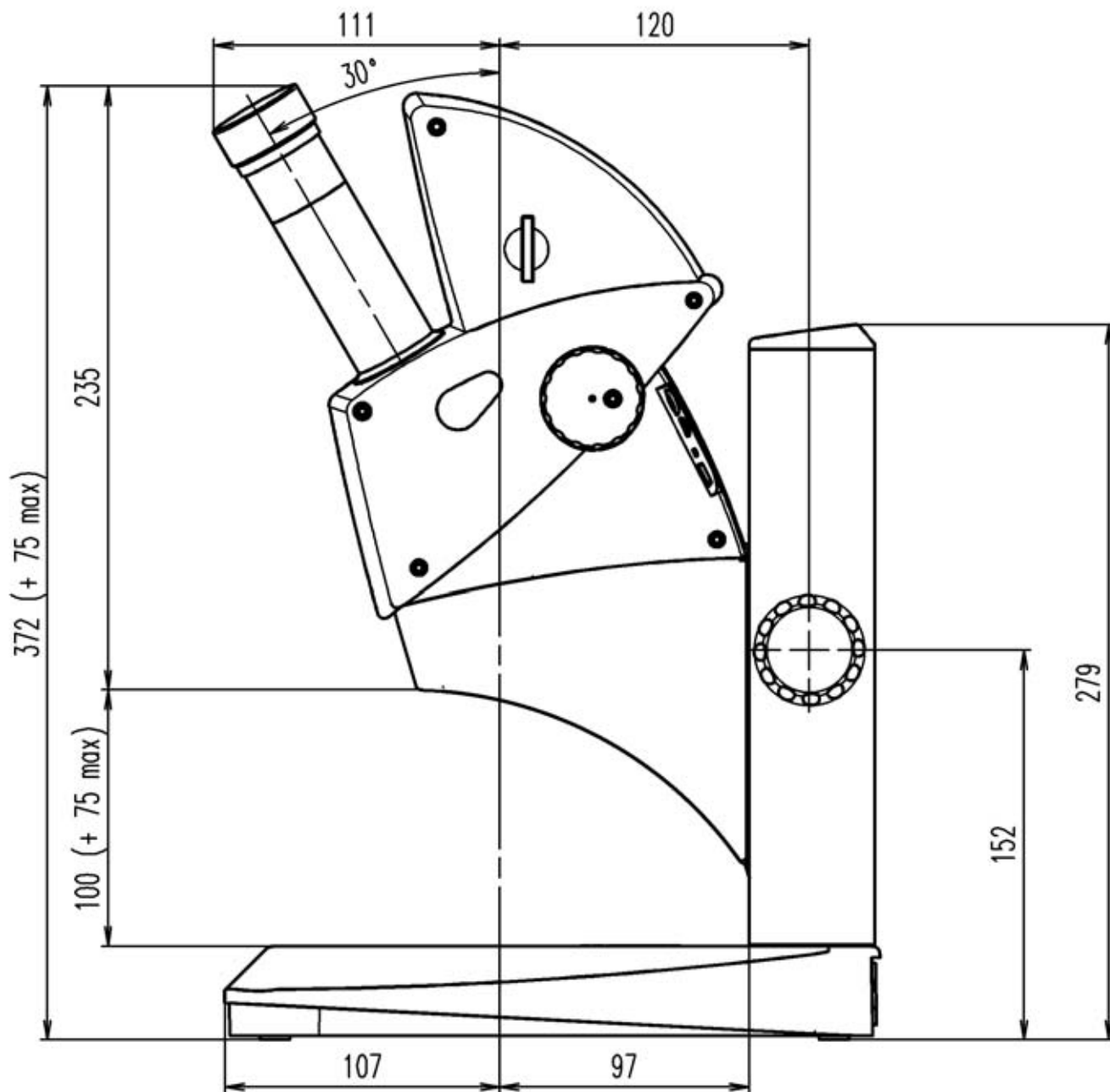

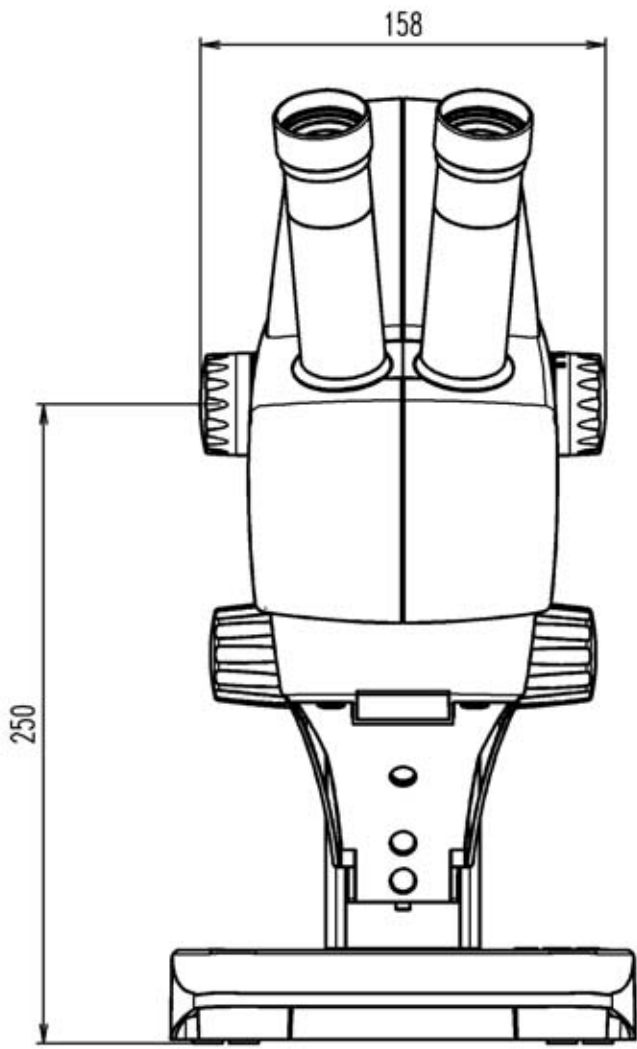
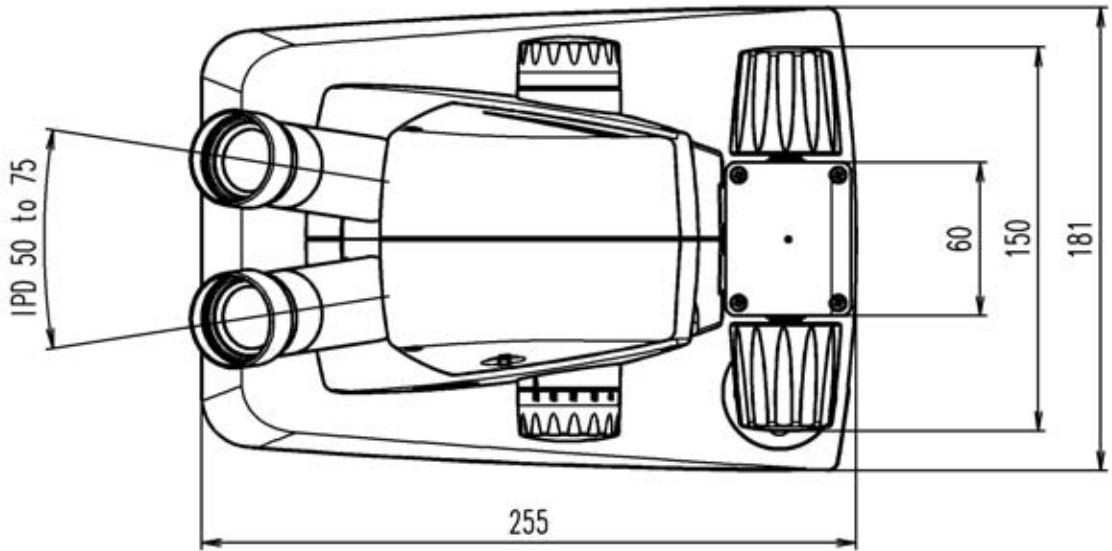





Leica Microsystems – the brand for outstanding products

Leica Microsystems' mission is to be the world's first-choice provider of innovative solutions to our customers' needs for vision, measurement, lithography and analysis of microstructures.

Leica, the leading brand for microscopes and scientific instruments, developed from five brand names, all with a long tradition: Wild, Leitz, Reichert, Jung and Cambridge Instruments. Yet Leica symbolizes innovation as well as tradition.

Leica Microsystems – an international company with a strong network of customer services

Australia:	Gladesville, NSW	Tel. +1 800 625 286	Fax +61 2 9817 8358
Austria:	Vienna	Tel. +43 1 486 80 50 0	Fax +43 1 486 80 50 30
Canada:	Richmond Hill/Ontario	Tel. +1 905 762 20 00	Fax +1 905 762 89 37
China:	Hong Kong	Tel. +8522 564 6699	Fax +8522 564 4163
Denmark:	Herlev	Tel. +45 44 5401 01	Fax +45 44 5401 11
France:	Rueil-Malmaison Cédex	Tel. +33 1 4732 8585	Fax +33 1 4732 8586
Germany:	Bensheim	Tel. +49 6251 1360	Fax +49 6251 136 155
Italy:	Milan	Tel. +39 02 57 486 1	Fax +39 02 5740 3273
Japan:	Tokyo	Tel. +81 3 543 596 09	Fax +81 3 543 596 15
Korea:	Seoul	Tel. +82 2 514 6543	Fax +82 2 514 6548
Netherlands:	Rijswijk	Tel. +31 70 41 32 130	Fax +31 70 41 32 109
Portugal:	Lisbon	Tel. +35 1 213 814 766	Fax +35 1 213 854 668
Singapore:		Tel. +65 6 77 97 823	Fax +65 6 77 30 628
Spain:	Barcelona	Tel. +34 93 494 9530	Fax +34 93 494 9532
Sweden:	Sollentuna	Tel. +46 8 625 45 45	Fax +46 8 625 45 10
Switzerland:	Glattbrugg	Tel. +41 44 809 34 34	Fax +41 44 809 34 44
United Kingdom:	Milton Keynes	Tel. +44 1908 246 246	Fax +44 1908 609 992
USA:	Bannockburn/Illinois	Tel. +1 800 248 0123	Fax +1 847 405 0164

and representatives of Leica Microsystems
in more than 100 countries.

In accordance with the ISO 9001 certificate, Leica Microsystems (Switzerland) Ltd, Business Unit Stereo & Microscope Systems has at its disposal a management system that meets the requirements of the international standard for quality management. In addition, production meets the requirements of the international standard ISO 14001 for environmental management.

The companies of the Leica Microsystems Group operate internationally in four business segments, where we rank with the market leaders.

• Microscopy Systems

Our expertise in microscopy is the basis for all our solutions for visualization, measurement and analysis of microstructures in life sciences and industry. With confocal laser technology and image analysis systems, we provide three-dimensional viewing facilities and offer new solutions for cytogenetics, pathology and materials sciences.

• Specimen Preparation

We provide comprehensive systems and services for clinical histo- and cytopathology applications, biomedical research and industrial quality assurance. Our product range includes instruments, systems and consumables for tissue infiltration and embedding, microtomes and cryostats as well as automated stainers and coverslipppers.

• Medical Equipment

Innovative technologies in our surgical microscopes offer new therapeutic approaches in microsurgery.

• Semiconductor Equipment

Our automated, leading-edge measurement and inspection systems and our E-beam lithography systems make us the first choice supplier for semiconductor manufacturers all over the world.

Leica Microsystems (Switzerland) Ltd
Stereo & Microscope Systems
CH-9435 Heerbrugg

Telephone +41 71 726 33 33
Fax +41 71 726 33 99
www.leica-microsystems.com

Leica
MICROSYSTEMS