



# Leica MacroFluo™

Technical information

# Leica MacroFluo™

## Technical data, features

<b>Designation</b>	<b>Leica MacroFluo™ with 6.3 : 1 zoom</b>	<b>Leica MacroFluo™ with 16 : 1 zoom</b>
Microscope type	Macroscope with vertical beam path, apochromatic zoom system, incident illuminator, fluorescence illumination coupled with the zoom optical system, and trinocular tube	
Zoom system	Apochromatic 6.3 : 1 zoom Leica Z6 APO, lead-free	Apochromatic 16 : 1 zoom Leica Z16 APO, lead-free
Zoom factor	0.57 – 3.6×	0.57 – 9.2×
Switchable zoom positions for repetitive tasks	0.57 / 0.8 / 1 / 1.25 / 1.6 / 2 / 2.5 / 3.2 / 3.6	0.57 / 0.8 / 1 / 1.25 / 1.6 / 2 / 2.5 / 3.2 / 4 / 5 / 6.3 / 8 / 9.2
Tube	Trinocular tube FSA HC L 3TP 4/5/7 with: – Photo-TV output 100% : 0% / 50% : 50% / 0% : 100% – Viewing angle 30°	
Integrated iris diaphragm	for continuous depth of field adjustment	
<b>Designation</b>	<b>Leica MacroFluo™ with automated 6.3 : 1 zoom</b>	<b>Leica MacroFluo™ with automated 16 : 1 zoom</b>
Microscope type	Macroscope with vertical beam path, motorized, apochromatic zoom system, incident illuminator, fluorescence illumination coupled with the zoom optical system, and trinocular tube	
Zoom system, motorized	Apochromatic 6.3 : 1 zoom Leica Z6 APO A, lead-free	Apochromatic 16 : 1 zoom Leica Z16 APO A, lead-free
Zoom factor	0.57 – 3.6×	0.57 – 9.2×
Motorized zoom	Continuously motorized and approachable positions	Continuously motorized and approachable positions
Tube	Trinocular tube FSA HC L 3TP 4/5/7 with: – Photo-TV output 100% : 0% / 50% : 50% / 0% : 100% – Viewing angle 30°	
Motorized iris diaphragm	For continuous adjustment of depth of field	For continuous adjustment of depth of field
Motorized fine focus	Integrated, 10mm travel	Integrated, 10mm travel
<b>Fluorescence illuminator</b>		
Type	Coaxial incident illuminator LRF 4/22 and carrier for incident light fluorescence and incident light bright field with: – Reflector disk for 5 filter blocks, 0-pixel technology = no pixel offset during change – Aperture and field diaphragm can be centered – Switchable blue filter BG 38 and UV light stop – Light trap for suppressing ambient light	
Fluorescence filter	– Filter system (excitation filter, beam-splitting mirror, and suppression filter) on one filter block – Comprehensive assortment of filter blocks (see p. 6), filter combinations to customer specifications	
Light source	Lamp housing 106 z with: – High-pressure mercury burner 100 W (direct current, stabilized/non-stabilized, type 103 W/2) – Chromatically corrected collector, focusable – Lamp mount with centering – ebq 100 supply unit	
Safety measures	UV antiglare shield, UV light stop, stray-light protection for lamp housing	

# Leica MacroFluo™ Module system

<b>Optical accessories</b>			
Objectives	Type/magnification factor	Working distance	Max. object field Ø
	– Planapo 1×	97mm	35mm
	– Planapo 0.8×	112mm	44mm
	– Planapo 2×	39mm	17.5mm
	– Planapo 0.5×	187mm	70mm
	– Achromat 0.63×	149mm	56mm
	– Achromat 0.5×	187mm	70mm
	– Achromat 0.32×	297mm	112mm
	– Planapo 5×/0.5 LWD	19mm	5mm
Fine focusing	10-mm travel, 1 micron resolution (Z6 APO / Z16 APO) (motorized, integrated for Z6 APO A and Z16 APO A)		
Eyebase	55mm – 75mm		
Large field eyepiece for spectacle wearers	Wide-field HC plan eyepieces 10×/22, 10×/25		
<b>Imaging</b>			
Image recording/storage and processing for fluorescence	Various digital FireWire camera systems		
Software for image archiving, analysis and processing	Leica Image Manager with Image Overlay and Multifocus modules, FW4000, QWin, LAS		
Tubes	– Trinocular tube FSA HC L 3TP (1.25×) – Trinocular tube HL L 2 TU		
Video objectives	– 0.35×, 0.5×, 0.63, 1× with C-mount – 2/3", 1/2" B-mount		
<b>Stands, illuminations</b>			
Transmitted-light stands	High-performance HL RC™ base with innovative contrast methods, high-performance HL base, stands for bright field and bright/dark field		
Incident-light stand	with stage plate, black and white, Ø 120mm		
Motor focus system	with 500mm column, control via handswitch, footswitch or PC		
Manual focusing drive	Coarse/fine focus, adjustable torque, with 500mm column		
Stages	Gliding stage, heating stage Leica MATS thermocontrol system, polarization		
Additional illuminations	Cold-light sources		
	Additional accessories see assembly diagram and scope of delivery.		



# Optical data

## Visual data with HC plan 10×/25 eyepieces

Objectives	Planapo 1× (10 447 176)		Planapo 2× (10 447 178)		Planapo 5× / 0.5 (10 447 243)		Planapo 0.5× (10 447 177)		Planapo 0.8× (10 446 360)		
Working distances	97mm		39mm		19.8mm		187mm		112mm		
Zoom position	Total magnification ×	Object field diameter mm	Total magnification ×	Object field diameter mm	Total magnification ×	Object field diameter mm	Total magnification ×	Object field diameter mm	Total magnification ×	Object field diameter mm	
0.57	6.3:1	7.1	35	14.3	17.5	35.6	7	3.6	70	5.7	44
0.8		10	25	20	12.5	50	5	5	50	8	31
1		12.5	20	25	10	62.5	4	6.3	40	10	25
1.6		20	12.5	40	6.25	100	2.5	10	25	16	15.6
2		25	10	50	5	125	2	12.5	20	20	12.5
2.5		31.3	8	62.5	4	156	1.6	15.6	16	25	10
3.2		40	6.25	80	3.1	200	1.25	20	12.5	32	7.8
3.6		45	5.6	90	2.9	225	1.1	22.5	11	36	7
4		50	5	100	2.5	250	1	25	10	40	6.25
5	62.5	4	125	2	313	0.8	31	8	50	5	
6.3	78.8	3.2	158	1.6	394	0.6	39.4	6.4	63	4	
8	100	2.5	200	1.25	500	0.5	50	5	80	3.1	
9.2	16:1	115	2.2	230	1.1	575	0.4	57.5	4.4	92	2.7

Eyepieces HC Plan 10×/25 (11 507 808) / tube factor: 1.25× Trinocular tube FSA HC L 3TP / open iris diaphragm

## Data with Leica DFC300 FX Full Frame digital camera

Objectives	Planapo 1× (10 447 176)		Planapo 2× (10 447 178)		Planapo 5× / 0.5 (10 447 243)		Planapo 0.5× (10 447 177)		Planapo 0.8× (10 446 360)		
Working distances	97mm		39mm		19.8mm		187mm		112mm		
Zoom position	Magnification Chip : Object	Object field projected onto Chip mm × mm	Magnification Chip : Object	Object field projected onto Chip mm × mm	Magnification Chip : Object	Object field projected onto Chip mm × mm	Magnification Chip : Object	Object field projected onto Chip mm × mm	Magnification Chip : Object	Object field projected onto Chip mm × mm	
0.57	6.3:1	0.45	20 15	0.9	10 7.5	2.2	4 3	0.2	40 30	0.4	25 18.7
0.8		0.6	14 11	1.3	7 5.3	3.2	2.85 2	0.3	28.5 21	0.5	17.8 13
1		0.79	11.4 8.5	1.6	5.7 4.3	3.9	2.9 1.7	0.4	22.8 17	0.6	14 10.6
1.6		1.3	7.1 5.3	2.5	3.6 2.7	6.3	1.4 1.1	0.6	14 11	1	8.9 6.7
2		1.6	5.7 4.3	3.15	2.9 2.1	7.9	1 0.9	0.8	11 8.5	1.3	7 5.3
2.5		2	4.6 3.4	3.9	2.3 1.7	9.8	0.9 0.7	1	9 6.8	1.9	5.7 4.3
3.2		2.5	3.6 2.7	5	1.8 1.3	12.6	0.7 0.5	1.3	7 5.3	2	4.5 3.3
3.6		2.8	3.2 2.4	5.7	1.6 1.2	14.2	0.6 0.47	1.4	6.3 4.7	2.3	4 3
4		3.2	2.9 2.1	6	1.4 1	15.8	0.6 0.4	1.6	5.7 4.3	2.5	3.6 2.7
5	3.9	2.3 1.7	7.9	1 0.85	19.7	0.5 0.3	2	4.6 3.4	3.2	2.9 2	
6.3	5	1.8 1.4	9.9	0.9 0.7	24.8	0.4 0.3	2.5	3.6 2.7	4	2.3 1.7	
8	6	1.4 1	12.6	0.7 0.5	31.5	0.3 0.2	3	2.9 2	5	1.8 1.3	
9.2	16:1	7.25	1.2 0.93	14.5	0.6 0.5	36	0.2 0.2	3.6	2.5 1.9	5.8	1.5 1.2

Tube factor: 1.25× trinocular tube FSA HC L 3TP / video objective 0,63× / open iris diaphragm



### Leica MacroFluo™ with 6.3 : 1 zoom (Z6 APO or Z6 APO A)

<b>Visual data with trinocular tube FSA HC L 3TP (tube factor 1.25×) / eyepieces 10×/25</b>			
Objective	Planapo 1×	Planapo 2×	Planapo HR 5×
Zoom range	7.1× – 45×	14.3× – 90×	35.5× – 225×
Resolution	60 – 351 Lp/mm	120 – 702 Lp/mm	max. 1500 Lp/mm
Max. numeric Aperture	0.117 nA	0.234 nA	0.5 nA
Finest visible structure width	1.4 μm	0.71 μm	0.33 μm
Object field Ø	5.6 – 35mm	2.8 – 17.5mm	1.1 – 7mm
Max. depth of field	3.1mm	0.8mm	0.1mm
Working distance	97mm	39mm	19mm
<b>Data with Leica DFC300 FX Full Frame / digital camera FSA HC L 3TP trinocular tube (tube factor 1.25×) / video objective 0.63×</b>			
Magnification chip: Object	0.45× – 2.8×	0.9× – 5.7×	2.2× – 14.2×
Digital resolution	17.4 – 110 Lp/mm	35 – 220 Lp/mm	87 – 549 Lp/mm
Object field projected onto chip	20 × 15mm / 3.2 × 2.4mm	10 × 7.5mm / 1.6 × 1.2mm	4 × 3mm / 0.6 × 0.5mm
Max. depth of field	1.4mm	0.35mm	0.6mm

### Leica MacroFluo™ with 16 : 1 zoom (Z16 APO or Z16 APO A)

<b>Visual data with trinocular tube FSA HC L 3TP (tube factor 1.25×) / eyepieces 10×/25</b>			
Objective	Planapo 1×	Planapo 2×	Planapo HR 5×
Zoom range	7.1× – 115×	14.3× – 230×	35.5× – 575×
Resolution	51 – 336 Lp/mm	102 – 672 Lp/mm	max. 1500 Lp/mm
Max. numeric aperture	0.112 nA	0.224 nA	0.5 nA
Finest visible structure width	1.48 μm	0.74 μm	0.33 μm
Object field Ø	2.2 – 35mm	1.1 – 17.5mm	0.4 – 7mm
Max. depth of field	3.8mm	1mm	0.15mm
Working distance	97mm	39mm	19mm
<b>Data with Leica DFC300 FX Full Frame digital camera / FSA HC L 3TP trinocular tube (tube factor 1.25×) / video objective 0.63×</b>			
Magnification chip: Object	0.45× – 7.25×	0.9× – 14.5×	2.2× – 36.2×
Digital resolution	17.4 – 281 Lp/mm	35 – 562 Lp/mm	87 – 1404 Lp/mm
Object field projected onto chip	20 × 15mm / 1.24 × 0.93mm	10 × 7.5mm / 0.6 × 0.5mm	4 × 3mm / 0.25 × 0.19mm
Max. depth of field	1.8mm	0.5mm	0.7mm

## Filter blocks for macro-fluorescence

Filter block	Fluorochrome	Excitation	Excitation filter	Dichr. mirror	Suppression filter	Order no.
A	various	UV	BP 340-380	400	LP 425	11 513 873
+ A4	various	UV	BP 360/40	400	BP 470/40	11 513 874
D	various	UV + violet	BP 355-425	455	LP 470	11 513 875
E4	various	violet + blue	BP 436/7	455	LP 470	11 513 876
H3	various	violet + blue	BP 420-490	510	LP 515	11 513 877
I3	various	blue	BP 450-490	510	LP 515	11 513 878
K3	various	blue	BP 470-490	510	LP 515	11 513 879
+ L5	various	blue	BP 480/40	505	BP 527/30	11 513 880
M2	various	green	BP 546/14	580	LP 590	11 513 881
N2.1	various	green	BP 515-560	580	LP 590	11 513 882
+ N3	various	green	BP 546/12	565	BP 600/40	11 513 883
G/R	various	FITC/Texas Red Blue/green	BP 490/20 BP 575/30	505 600	BP 525/20 BP 635/40	11 513 884
+ TX2	TEXAS RED	green	BP 560/40	595	BP 645/75	11 513 885
B/G/R	various various	DAPI/FITC/TEXAS RED UV/blue/green	BP 420/30 BP 495/15 BP 570/20	415 510 590	BP 465/20 BP 530/30 BP 640/40	11 513 886
+ Y3	CY3	green	BP545/30	565	BP 610/75	11 513 887
+ Y5	CY5	red	BP 620/60	660	BP 700/75	11 513 888
+ Y7	CY7	red	BP 710/75	750	BP 810/90	11 513 889
FI/RH	various	FITC/Rhodamine Blue/green	BP 490/15 BP 560/25	500 580	BP 525/20 BP 605/30	11 513 891
+ GFP	Green-FP	blue	BP 470/40	500	BP 525/50	11 513 890
+ YFP	Yellow-FP	blue	BP 500/20	515	BP 535/30	11 513 893
+ Red GFP	Red-FP	green	BP 546/12	560	BP 605/75	11 513 894
CGFP	Cyan-FP	violet / blue	BP 436/20	455	BP 480/40	11 513 892
BFP/GFP	various	Blue FP/UV Green FP/blue	BP 385/15 BP 485/20	420 510	BP 460/20 BP 437/45	11 513 895
CFP/YFP	various	Cyan FP/violet+blue Yellow FP/blue	BP 436/12 BP500/20	445 515	BP 467/37 BP 545/45	11 513 865
CFP/YFP/Cyan FP/DsRed		Violet+blue Yellow FP/blue Red FP/green	BP 436/8 BP 495/12 BP 580/20	445 510 595	BP 460/25 BP 535/35 BP 630/55	11 513 897
Pol		IGS	Polarizer	Neutral	Analyzer	11 513 813
Empty system*			0	0	0	11 513 842

BP band-pass filter, wavelength in nm

LP long-pass filter, edge wavelength in nm

+ Specifically for multi-parameter fluorescence

\* for instrumentation according to customer specifications

## Assignment of fluorochromes and filter blocks

Fluorochromes	Filter block
– Acridine-blue	A
– Acridine-yellow	I 3, H 3
– Acridine-orange	I 3, H 3
– Acridine-red	N 2.1, N 3
– Acriflavine	E 4, H 3
– Acriflavine feulgen SITS (AFS)	D
– Alizarin complexion	N 2.1
– Alizarin-red	N 2.1
– Allophycocyanine (APC)	Y 3, Y 5
– AMCA (Aminocoumarine)	A
– Aminoactinomycinn D-AAD	N 2.1, N 3
– Aniline-blue	A
– ACMA	E 4
– Astrazon brillant red 4G	N 2.1
– Astrazon red 6B	N 2.1
– Astrazon yellow 7 CLL	H 3
– Astrazon orange R	I 3, L 5
– Atabrin	E 4, H 3
– Auramin	I 3, H 3
– Aurophosphin	G I 3, H 3
– BCECF	L 5
– Berberine sulfate	H 3
– Benzoxanthene yellow	D
– BisAminophenyl Oxdiazol (BAO)	A
– Bisbenzimidide (Hoechst)	A, D
– Blankophor BA	A, D, H 3
– Blankophor SV	A
– BODIPY FL	L 5, K 3, I 3
– Brillant sulfoflavine FF	D, H 3
– Bromobimane (Thiolyte)	D
– Calcein	I 3
– Calcein-blue	A
– Calcium crimson	Y 3
– Calcium green	K 3, I 3, L 5

Fluorochromes	Filter block
– Calcium orange	M 2, N 2.1
– Calcofluor white	H 3, D
– Calcofluor white standard solution	A
– Carboxyfluoresceindiacetat C-FDA	I 3, L 5
– Cascade blue A,	D
– Catecholamine (Adrenaline, noradrenaline, dopa, dopamine)	D
– Chromomycine A (Mithramycine, olivomycine)	E 4
– Coriphosphine O	I 3, H 3
– Coumarine phalloidine	D
– Cy 3	Y 3
– Cy 5	Y 5
– Cy 7	Y 7
– DANS (Dimethylamino Naphtyl sulfonic acid)	A
– DAPI	A, D
– DAPI (selective)	A 4
– Dansylchloride	A
– DIPI	A
– Dil	Y 3
– DiO	I 3, K 3
– Diphenyl brilliant flavine 7	GFF H 3
– Dopamine	A
– DPH (Diphenylhexaria)	A
– Eosin B	N 2.1
– Ethidiumbromide	N 2.1
– Euchrysine	H 3, D
– Evans blue	N 2.1
– Fast blue	A
– Fast green FC G	N 2.1, M 2
– Feulgen	N 2.1, TX 2
– FDA (FluoresceinDiAcetate)	I 3, H 3, K 3, L 5
– FIF (Formaldehyde induced fluorescence)	D, A

<b>Fluorochromes</b>	<b>Filter block</b>
– FITC (FlouresceinIsoThioCyanate)	I 3, H 3, K 3, L 5
– FITC/Ethidiumbromide	I 3, L 5, N 2.1
– FITC (selective)	L 5
– Texas red (selective)	TX 2
– FITC/TRITC	L 5, N 3
– TRITC (selective)	N 3
– Fluo 3	I 3, L 5
– Fluoro Gold	A
– Fluram (Fluorescamine)	A
– Genacryl brilliant red B	N 2.1
– Genacryl brilliant yellow	E 4
– Generic blue	D
– GFP (Green Fluorescent Protein)	GFP
– Granular blue	A
– Haematoporphyrin	N 2.1
– Hoechst dye no. 33258	A, D, A 4
– Hoechst dye no. 33342	A, D, A 4
– Hydroxy-4-methylconmarin	A
– Lissamin-rhodamin B (RB 200)	N 2.1, M 2
– Lucifer Yellow	E 4
– Magdala Red	N 2.1
– Maleimide	A
– Mepacrin	D
– Merocyanine 540	N 2.1
– Mithramycine	E 4
– MPS (Methy green pyronine stilbene)	A
– Nile Red	I 3, L 5, N .21
– Nuclear Fast Red	N 2.1, M 2, N 3
– Nuclear Yellow	A
– Olyvomycine	E 4
– Oregon Green (488, 500, 514)	L 5
– Oxytetracycline	D
– Pararosanine (Feulgen)	N 2.1, TX 2
– Phosphine 3 R	I 3, H 3

<b>Fluorochromes</b>	<b>Filter block</b>
– Phycoerythrin (PE)	N 2.1, N 3
– Primulin O	D
– Procion Yellow	D, E 4, H 3
– Propidiumiodide	N 2.1
– Pyronin B	N 2.1, M 2
– Quinacrine mustard (QM)	E 4
– Resorufin	N 2.1, Y 3
– Reverine	D
– Rhodamine B	N 2.1
– Rhodamine 123	I 3, L 5
– Acid fuchsin	N 2.1, M 2
– Serotine	A, D
– SITS (Stilben Iso Thio Sulfonic acid)	A
– SITS Acriflavine Feulgen	D
– Spectrum orange	M 2, N 2.1
– Sulfaflavine	A
– Tetracyclines: Oxytetracycline, tetracycline, Reverine (Pyrrolidino-methyltetracycline), Chlortetracycline, Dimethylchlortetracycline	D
– Texas red	TX 2
– Thiazine-red R	N 2.1, M 2
– Thioflavine S	H 3, D
– Thioflavine TCN	A
– Thiolyte (Bromobimane)	D, A
– TRITC (Tetramethyl rhodamine Isothiocyanat)	N 2.1, N 3
– TRITC (selective)	N 3
– True Blue	A
– Uranine B	H 3
– Uvitex 2 B	A, D
– XRITC	N 2.1, N 3
– Xylene-orange	N 2.1, M 2

## Scope of delivery

Leica MacroFluo™ systems are modular and can be combined individually. MacroFluo™ equipment consists of:

- a zoom system of your choice with an objective of your choice, poss. fine focusing (optional for manual zoom systems)
- the carrier for the incident illuminator
- the incident illuminator
- filter blocks of your choice
- the lamp housing with stray-light protection and supply unit
- the UV protection screen with arm and clamp
- a trinocular tube of your choice
- two eyepieces of your choice
- a stand base of your choice
- a focusing drive of your choice
- a high-performance digital camera with photo/video adapters of your choice

### Zoom system and objectives

10 447 174	Leica Z6 APO 6.3:1 zoom system, apochromatic
10 447 173	Leica Z16 APO 16:1 zoom system, apochromatic
10 446 368	Leica Z6 APO A 6.3:1 motorized zoom system, apochromatic
10 446 369	Leica Z16 APO A 16:1 motorized zoom system, apochromatic
10 447 401	RS232 Interface
10 447 163	Motor focus handheld controller
10 447 080	Universal handheld controller Z6/Z16 APO A
10 446 182	Footswitch for motor focus
10 447 379	CTR connecting cable for motor focus
10 447 176	Planapo objective 1.0×
10 447 177	Planapo objective 0.5×
10 446 360	Planapo objective 0.8×
10 447 178	Planapo objective 2.0×
10 447 243	HR planapo objective 5.0×/0.5 LWD, FAA 19mm
10 447 085	HR objective 20× (eff. 10×)/0.42, FAA 13mm* * Please also order 10 447 338
10 447 338	Adapter for Mitutoyo/Optem objective
10 447 175	Fine focusing, 10mm travel, 1 micron resolution (Z6/Z16 APO)
10 447 083	Adapter for achromatic objective M series
10 422 564	Achromatic objective 0.32×
10 422 563	Achromatic objective 0.5×
10 445 201	Achromatic objective 0.63×

### Incident illuminator

10 447 389	Carrier for incident illuminator LRF 4/22
11 505 203	Coaxial incident illuminator LRF 4/22 for incident light fluorescence and incident light bright field (for order numbers of the various filter blocks: see pages 6)

11 504 069	Lamp housing 106 z, with lamp mount for Hg 100 W and 103 W/2
10 446 271	Stray-light protection for lamp housing
11 500 325	Supply unit Hg 100 W and 103 W/2
11 500 138	Hg 100 W burner
11 500 321	Hg 103 W/2 burner*

\* same as Hg 100 W, but with extended life.

Power cable acc. to country codes.

10 446 154	UV protection screen
10 399 211	Arm for protection screen
10 445 654	Clamp on side-faced column

### Trinocular tube

11 551 505	Trinocular tube FSA HC L 3TP 4/5/7
11 501 598	Trinocular tube HL L 2 TU
11 505 416	Trinocular tube BDT 25+ V100/50/0, mech.

11 507 808	Wide-field HC plan eyepiece 10×/22
11 507 807	Wide-field HC plan eyepiece 10×/25
11 621 500	MPV adapter, HC/delta
11 541 038	Vario TV adapter, delta, C-mount 0.55 – 1.1×
11 543 703	B-mount for 2/3"-CCD cameras
11 543 702	B-mount adapter 1×
11 543 706	C-mount adapter 1×
11 541 517	Vario TV adapter C-mount 0.32 – 1.6× HC
11 541 510	C-mount adapter 1× HC
11 541 537	C-mount adapter 0.63× HC
11 541 511	C-mount adapter 0.5× HC
11 541 512	C-mount adapter 0.35× HC

### Transmitted-light bases

Please supplement the transmitted-light bases 10 446 359, 10 445 367 and 10 445 363 by a fiber-optic light guide (active  $\varnothing$  f=10mm, end tube  $\varnothing$  f=13mm) and a light source.

10 446 359	Transmitted-light base HL RC™ for most stringent demands, positive/inverted/dynamic relief contrast, vertical/oblique illumination, single-side dark field, with glass stage plate, clear
10 445 367	Transmitted-light base HL, high performance, with mirror for vertical/oblique illumination, single-side dark field, with glass stage plate, clear
10 446 184	Supplementary condenser to optimize illumination at magnifications >100×, to 10 447 187 and 10 445 367
10 445 363	Transmitted-light base, bright/dark field with glass stage plate, clear
10 445 387	Transmitted-light base, bright field 20 W, with mirror for vertical/oblique illumination, with glass stage plate, clear, two 6 V/20 W halogen lamps and integrated 0 V–6 V 40 VA regulating transformer, 100 V–120 V/200 V–240 V
10 362 658	Halogen lamp, 6V/20W

# Leica MacroFluo™ Assembly diagram

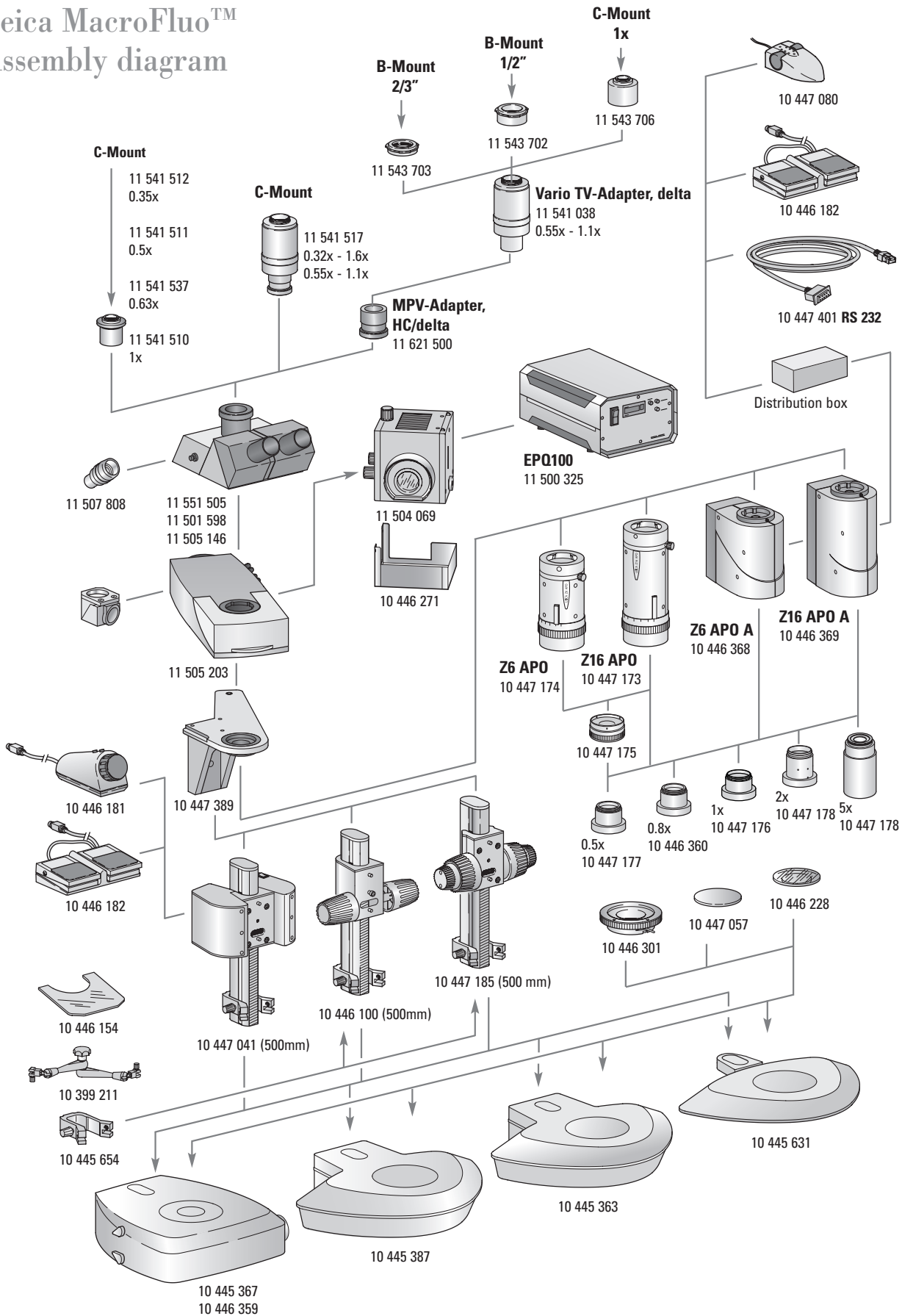

# Scope of delivery

## Incident-light base

10 445 631 Incident-light base, large, with stage plate, black and white

## Focusing drive for incident/transmitted-light bases

10 447 185 Focusing drive, coarse/fine, with 500mm column for incident/transmitted-light bases

10 446 100 Focusing drive, coarse, with 500mm column for incident/transmitted-light bases

10 446 181 Motor focus with 500mm column and power pack for incident and transmitted-light bases

10 446 181 Motor focus handheld controller

10 447 080 Universal handheld controller

10 446 182 Footswitch for motor focus

10 447 401 PC interface kit for motor focus control via PC (distribution box is part of the standard delivery of a Z6 APO A or Z16 APO A)

## Stages

10 446 301 Gliding stage  $\varnothing$  120mm

10 447 057 Stage plate black-and-white,  $\varnothing$  120mm

10 447 164 Leica MATS type A thermostage with control unit for transmitted-light base HL/HL RC

10 447 165 Leica MATS type B thermostage with control unit for transmitted-light base HF/DF

For details, see brochure M1-227-0

## Polarization

10 446 302 Rotating polarization stage with polarizer and glass stage plate, clear, for transmitted-light stands

10 382 130 Attachable mechanical stage for rotating polarization stage

10 361 719 Sensitive tint plate for rotating polarization stage

10 446 228 Glass stage plate with polarizer for transmitted-light stands

10 315 306 Analyzer in rotating mount

## Dust cover

10 362 677 Dust cover for photo equipment and universal stand (800mm column)

## MATS – Type A

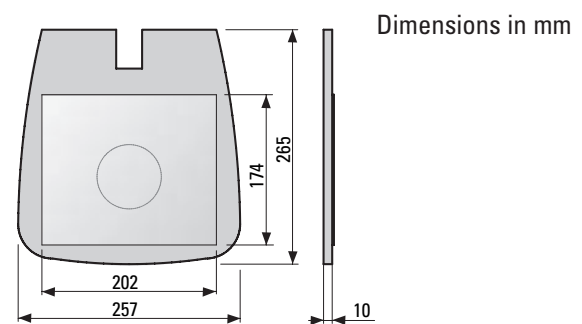

## MATS – Type B

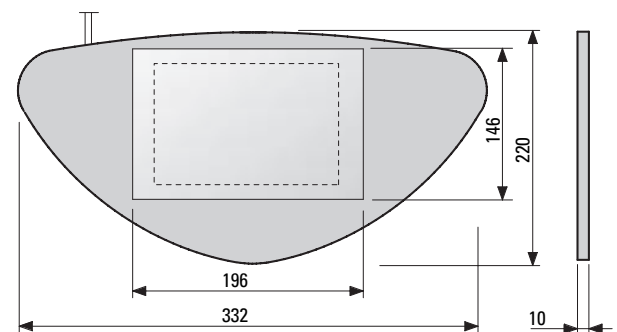



# Leica digital camera for fluorescence Assembly diagram

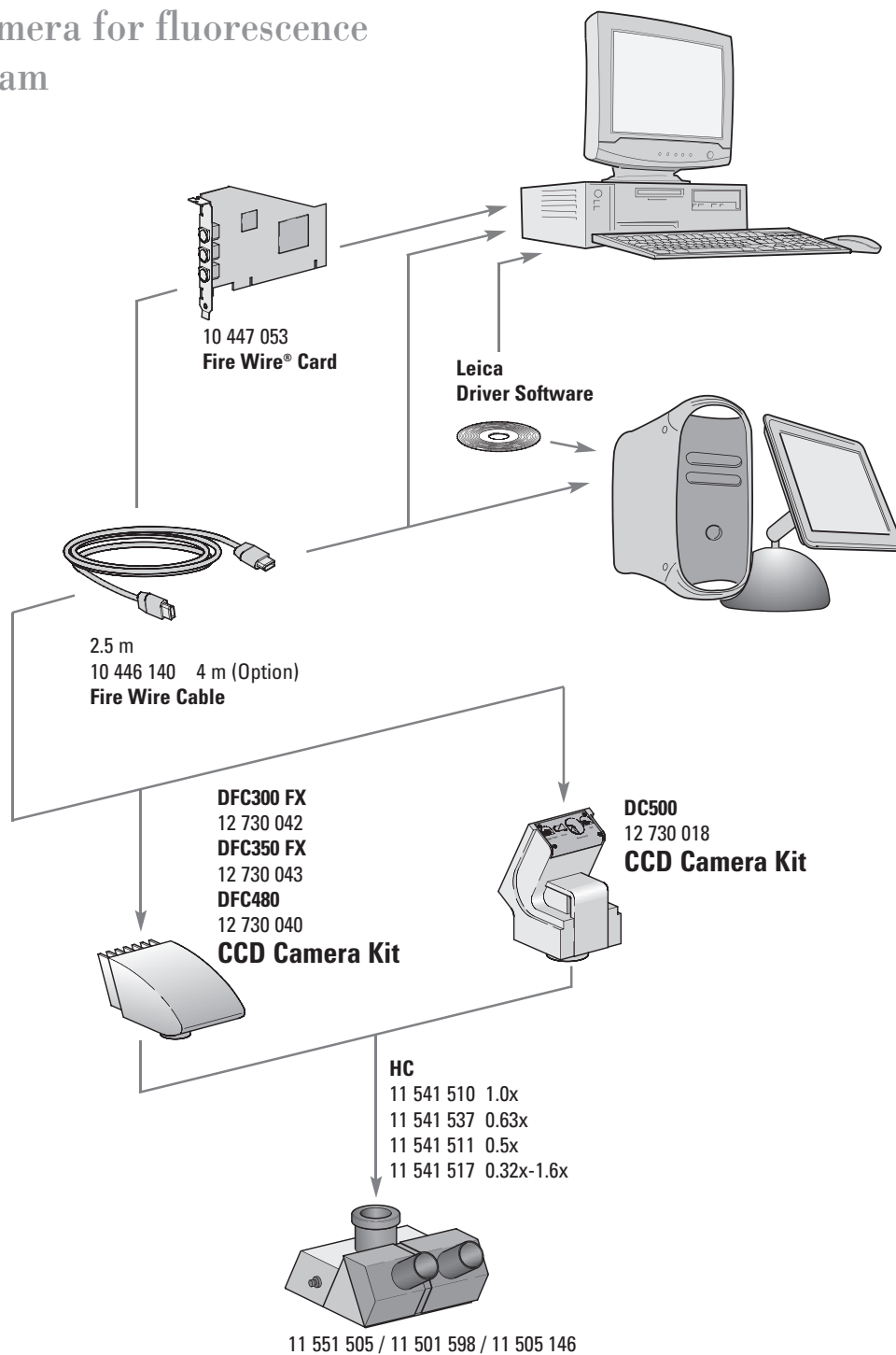

## Complete kits

12 730 042	Leica DFC300 FX R2 camera kit
12 730 043	Leica DFC350 FX R2 camera kit
12 730 040	Leica DFC480 R2 camera kit
12 730 018	Leica DC 500 R2 camera kit

All camera kits contain the appropriate Leica camera, Leica DFC Twain software for PC, Leica Firecam software for Mac, Leica IM50 Image Manager for PC, 6-pin to 6-pin FireWire cable, 2.5m

## Accessories

12 447 140	FireWire cable, 4 m, 6-pin to 6-pin
12 447 053	OHCI FireWire PCI card for PCs without FireWire ports
12 447 066	Laptop PCMCIA FireWire interface card
12 730 049	Laptop power kit, power adapter, 2.5-m FireWire cable, 6-to-4-pin adapter

# Leica digital cameras for fluorescence

	<b>Leica DFC480 R2</b>	<b>Leica DC500</b>		
Camera type	Extremely high-resolution digital color camera for microscopy purposes with control software	Extremely high-resolution digital color camera for microscopy purposes with pixel shift technology and control software		
<b>Sensor</b>	CCD with interlaced transmission, frame readout – ICX282AQF	CCD with interlaced transmission, frame readout – ICX085AK		
Sensor quality	Quality grade zero	Quality grade zero		
Color filter	RGB Bayer mosaic	RGB Bayer mosaic		
Protective color filter	Hoya CM500S (infrared cut-off 650 nm)	Hoya CM500S (infrared cut-off 650 nm)		
Diaphragm control	Electronic global diaphragm/readout in interlaced mode	Electronic global diaphragm/readout in interlaced mode with pixel steps		
Number of pixels	5.0 Mpixel, 2560 × 1920	1.3 Mpixel to 12 Mpixel		
Max. scaled resolution	11.25 Mpixel, 3940 × 2880	27 Mpixel, 5800 × 4060		
Sensitive area	8.7mm × 6.5mm	8.6mm × 6.9mm		
Pixel size	3.4 μm × 3.4 μm	6.7 μm × 6.7 μm		
Color depth	36 Bit	36 Bit		
A/D converter	12 Bit	14 Bit		
Dynamic range	> 59 dB	> 66 dB		
Readout noise	$\sigma < 4.5$ LSB (12 bit) typical	$\sigma < 8$ LSB (14 bit) typical		
Full well capacity				
Exposure time	200 μs .. 600 s	200 μs .. 600 s		
Dark current	0.22 LSB/s at 12 bit typical			
Quantum efficiency	Relative: Blue 460 nm 98%; Green 580 nm 100%; Red 610 nm 90%			
Gain control/offset control	10× / 0.. 255 LSB			
Live image	on the computer screen	on the computer screen		
Shading correction	Yes, stored for all formats	Yes, stored for all formats		
Brightness correction	in all Binning modes	in all Binning modes		
Cooling	Active Peltier thermoelectric cooling element	Active Peltier thermoelectric cooling element		
Cooling temperatures	Δ -20°K to ambient	Δ -20°K to ambient		
Image detail (region of interest)	NA	NA		
<b>Image formats</b>	<b>Pixel / area, mm<sup>2</sup></b>	<b>Rate of images/sec., Fast / Quality</b>	<b>Pixel</b>	<b>Rate of images/sec., Fast / Quality</b>
Full image color or mono	2560 × 1920 / 8.7 × 6.5	5 / 2.5	1300 × 1030 to 3900 × 3090	NA / 2.5
2 × 2 Binning color or mono	1280 × 960 / 8.7 × 6.5	10 / 5		
3 × 3 Binning color or mono	852 × 640 / 8.7 × 6.5	15 / 7.5		
4 × 4 Binning color or mono	640 × 480 / 8.7 × 6.5	20 / 10		
Progressive sub-sample color	1280 × 960 / 8.7 × 6.5	10 / NA		
Progressive R or G or B mono	1280 × 960 / 8.7 × 6.5	10 / 5		NA / 5
Modes	Formats in the modes Fast (29.5 MHz) or High quality (14.75 MHz) as defined above, trigger or free			
<b>Computer</b>	<b>PC</b>	<b>MAC</b>	<b>PC</b>	<b>MAC</b>
Minimum computer configuration	Pentium 4, 2 GHz, 512 MB RAM 24 bit graphics, 1024 × 768, CD-ROM drive 4-pin or 6-pin FireWire OHCI or free PCI slot	G4 or G5, 512 MB RAM CD-ROM drive	Pentium 4, 2 GHz, 512 MB RAM 24 bit graphics, 1024 × 768, CD-ROM drive 4-pin or 6-pin FireWire OHCI or free PCI slot	G4 or G5, 512 MB RAM CD-ROM drive
Supported operating systems	Windows 2000, Windows XP	MAC OS X	Windows 2000, Windows XP	MAC OS X
Software	Leica DFC Twain Leica DFC Twain	Leica Firecam	Leica DFC Twain Leica DFC Twain	Leica Firecam
<b>Interfaces</b>				
Optical	C-mount		C-mount	
Video adapter	0.63×		0.63×	
Data	Single FireWire cable – IEEE1394a with 6 contacts		Single FireWire cable – IEEE1394a with 6 contacts	
Connection for digital input	Opto-decoupled trigger		Opto-decoupled trigger	
Connection for digital output	Flash synch or readout active		Flash synch or readout active	
Software trigger	Asynchronous trigger		Asynchronous trigger	
<b>Power supply and ambient data</b>				
Power consumption	~6 W		~6 W	
Power supply	via FireWire cable		via FireWire cable	
Housing	Aluminum die cast		Aluminum die cast	
Dimensions	132 × 74 × 69mm		132 × 74 × 69mm	
Weight	495 g		495 g	
Operating temperature range	+5°C – +35°C		+5°C – +35°C	
Relative humidity	10%..80% non-condensing		10%..80% non-condensing	

<b>Leica DFC300 FX R2</b>		<b>Leica DFC350 FX R2</b>	
Highly sensitive cooled digital color camera for fluorescence microscopy with control software		Highly sensitive cooled digital monochrome camera for fluorescence microscopy with control software	
Interline progressive scan CCD – ICX285AQ		Interline progressive scan CCD – ICX285AQ	
Quality grade zero		Quality grade zero	
RGB Bayer mosaic		None	
Hoya CM500S (infrared cut-off 650nm)		Hoya CM500S (infrared cut-off 650nm)	
Electronic global diaphragm/ progressive scan readout		Electronic global diaphragm/ progressive scan readout	
1.4 Mpixel, 1392 × 1040		1.4 Mpixel, 1392 × 1040	
3.3 Mpixel, 2088 × 1560		3.3 Mpixel, 2088 × 1560	
9mm × 6.7mm		9mm × 6.7mm	
6.45µm × 6.45µm		6.45µm × 6.45µm	
36 Bit		36 Bit	
12 Bit		12 Bit	
> 62 dB		> 62 dB	
σ < 3 LSB (12 bit) typical		σ < 3 LSB (12 bit) typical	
16 000 electrons		16 000 electrons	
5 µs .. 600 s		5 ms – 600 s	
0.22 LSB/s at 12 bit typical		0.22 LSB/s at 12 bit typical	
Relative: Blue 475 nm 74%; Green 540 nm 95%; Red 620nm 100%		Relative: 510nm 100%	
10× / 0.. 255 LSB (12 bit) typical		10× / 0.. 255 LSB (12 bit) typical	
on the computer screen		on the computer screen	
Yes, stored for all formats		Yes, stored for all formats	
in all Binning modes		in all Binning modes	
Active Peltier thermoelectric cooling element		Active Peltier thermoelectric cooling element	
Δ -20°K to ambient		Δ -20°K to ambient	
Freely adjustable in 1-pixel steps from 1 × 1 to full resolution		Freely adjustable in 1-pixel steps from 1 × 1 to full resolution	
<b>Pixel</b>	<b>Rate of images/ sec., Fast / Quality</b>	<b>Pixel</b>	<b>Rate of images/ sec., Fast / Quality</b>
1392 × 1040	15 / 7.5	1392 × 1040	15 / 7.5
696 × 520	30 / 15	696 × 520	30 / 15
348 × 260	60 / 30	348 × 260	60 / 30
Formats in the modes Fast (29.5 MHz) or High quality (14.75 MHz) as defined above, trigger or free		Formats in the modes Fast (29.5 MHz) or High quality (14.75 MHz) as defined above, trigger or free	
<b>PC</b>	<b>MAC</b>	<b>PC</b>	<b>MAC</b>
Pentium 4, 2 GHz, 512 MB RAM 24 Bit graphics, 1024 × 768, CD-ROM drive 4-pin or 6-pin FireWire OHCI or free PCI slot	G4 or G5, 512 MB RAM CD-ROM drive	Pentium 4, 2 GHz, 512 MB RAM 24 bit graphics, 1024 × 768, CD-ROM drive 4-pin or 6-pin FireWire OHCI or free PCI slot	G4 or G5, 512 MB RAM CD-ROM drive
Windows 2000, Windows XP	MAC OS X	Windows 2000, Windows XP	MAC OS X
Leica DFC Twain Leica DFC Twain	Leica Firecam	Leica DFC Twain Leica DFC Twain	Leica Firecam
C-mount		C-mount	
0.63×		0.63×	
Single FireWire cable – IEEE1394a with 6 contacts		Single FireWire cable – IEEE1394a with 6 contacts	
Opto-decoupled trigger		Opto-decoupled trigger	
Flash synch or readout active		Flash synch or readout active	
Asynchronous trigger		Asynchronous trigger and software marking	
~5 W		~5 W	
via FireWire cable		via FireWire cable	
Aluminum die cast		Aluminum die cast	
132 × 74 × 69mm		132 × 74 × 69mm	
503g		503g	
+5°C – +35°C		+5°C – +35°C	
10%..80% non-condensing		10%..80% non-condensing	

# Dimensions of carrier

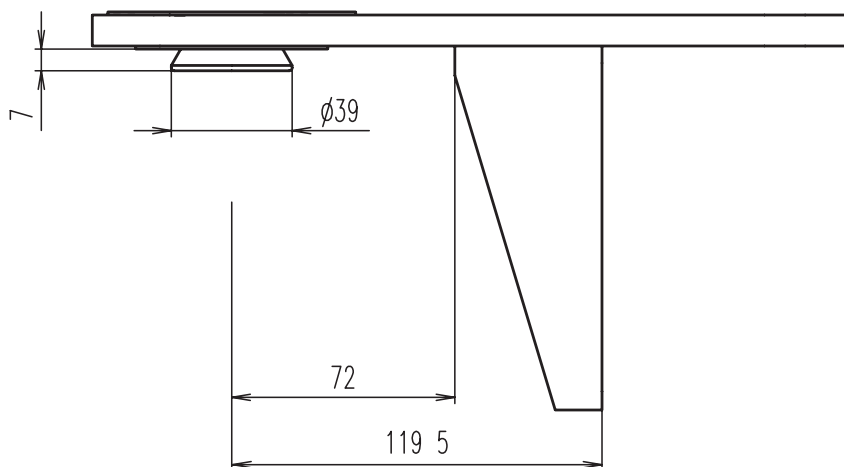
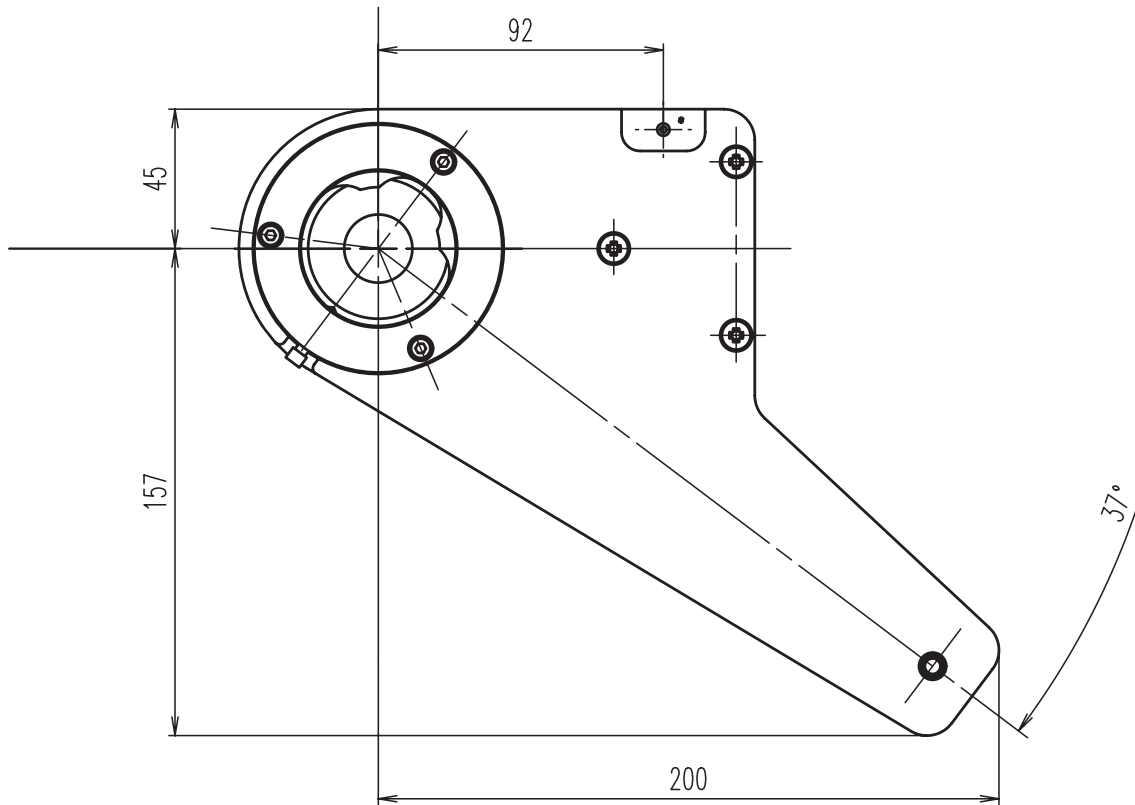
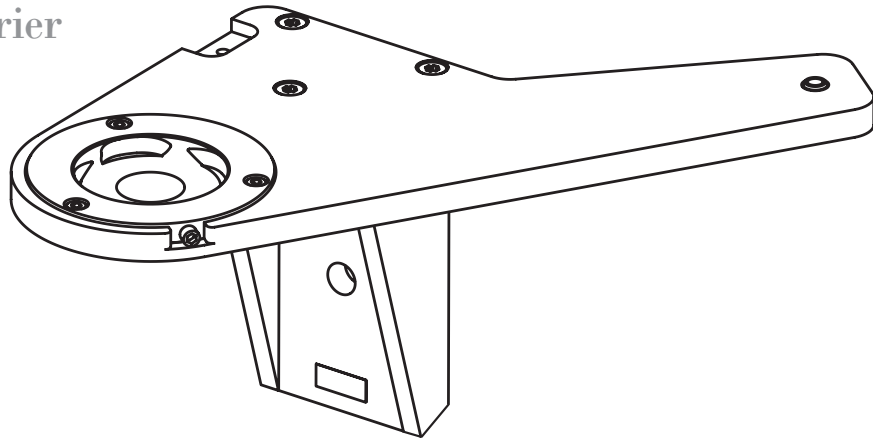

Dimensions in mm

# Dimensions of zoom systems

**Leica Z6 APO**

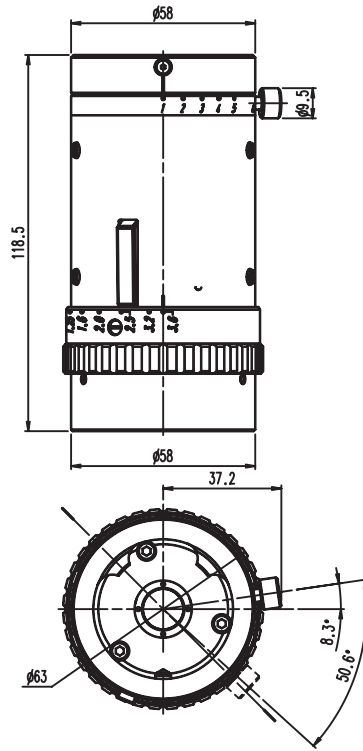

**Leica Z16 APO**

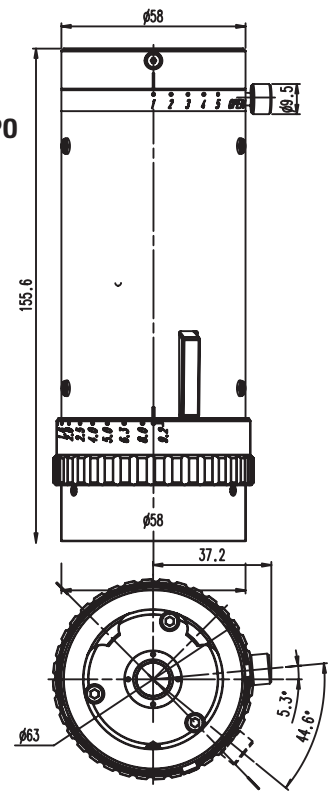

**Leica Z16 APO A**

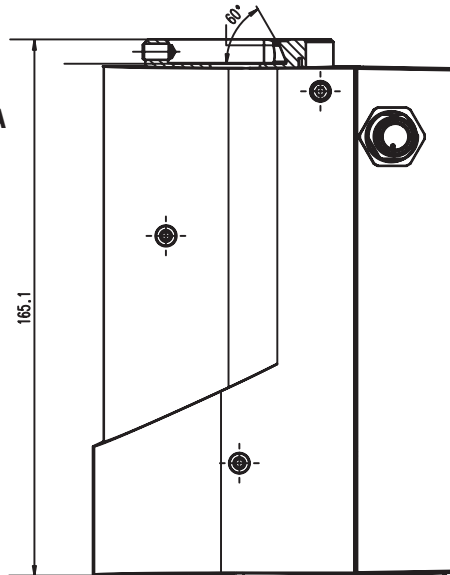

**Leica Z6 APO A**

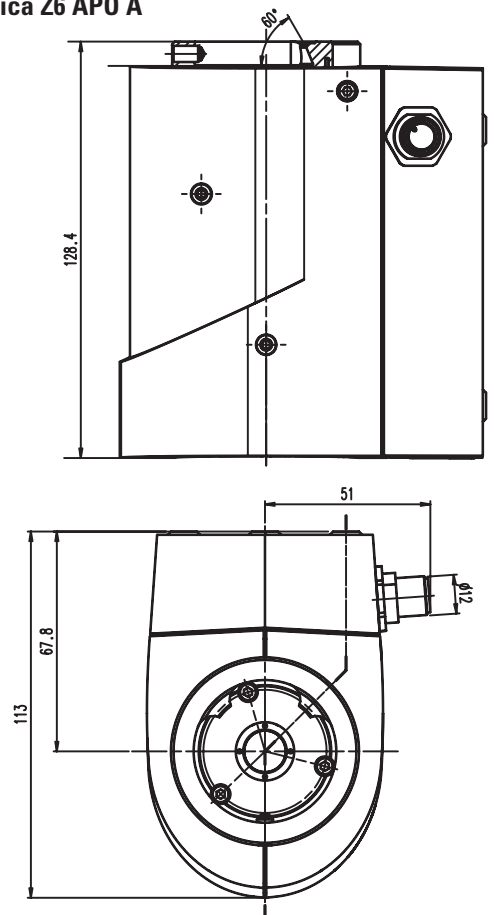

Dimensions in mm

# Dimensions of objectives, adapters

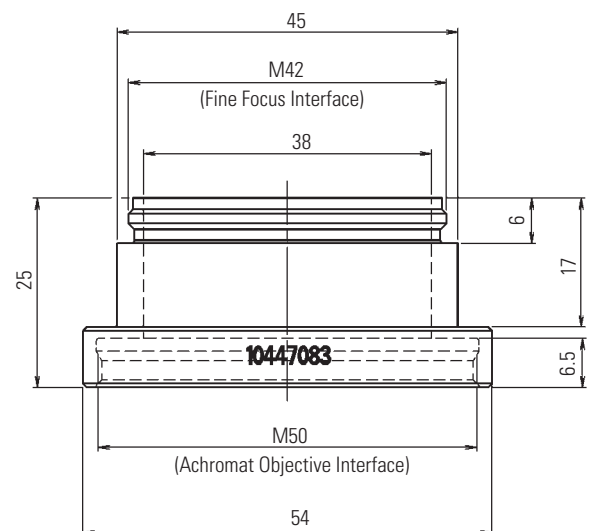
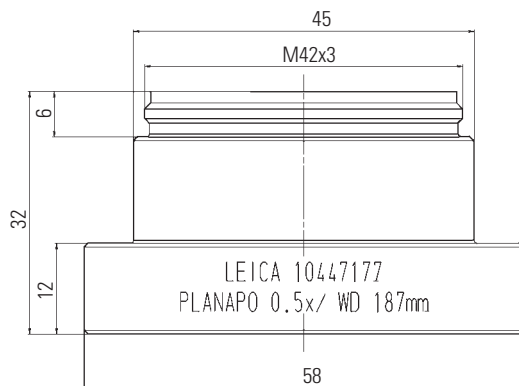
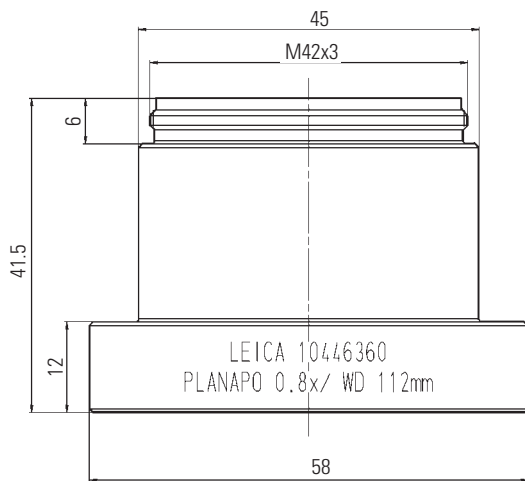
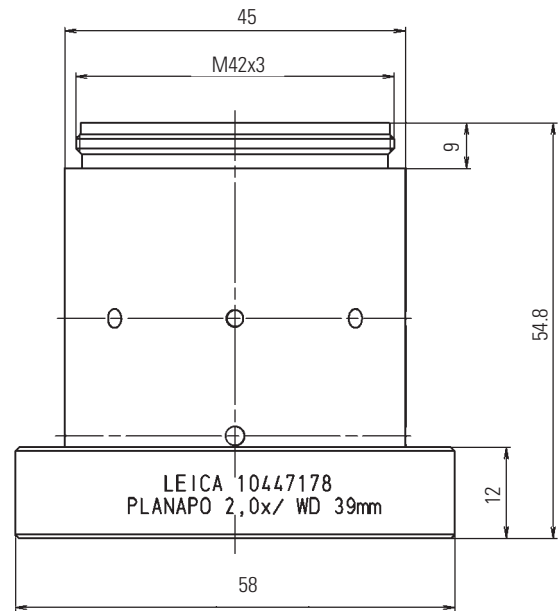
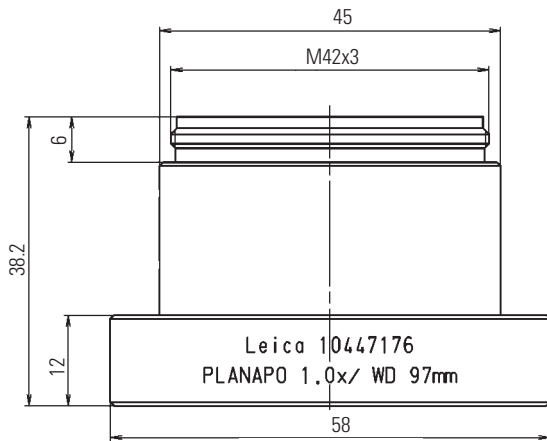

**Adapter for achromatic objectives**

# Information material

## Stereomicroscopes, zoom systems and accessories

All brochures available in German, English, French, Spanish, Italian.  
For M and S series stereomicroscopes, manuals are available in German, English, French, Spanish, Italian, Danish, Swedish, Dutch, Finnish, Greek, Portuguese, Estonian, Latvian, Lithuanian, Polish, Czech, Slovenian, Hungarian, Slovak

Please also visit our homepage: [www.stereomicroscopy.com](http://www.stereomicroscopy.com)

There you will find the latest information and updates as well as numerous examples of practical application for our stereomicroscopes in industry and life science. You can also view, print and save any brochures and the latest manuals.

Stereomicroscope Leica MS5, MZ6	M1-141-0
Stereomicroscope Leica MZ7 <sub>5</sub>	M1-175-0
Stereomicroscope Leica MZ9 <sub>5</sub>	M1-195-0
Stereomicroscope Leica MZ12 <sub>5</sub>	M1-125-0
Stereomicroscopes Leica MZ16 and MZ16 A	M1-116-0
Fluorescence stereomicroscope Leica MZ16 F	M1-116-8
Motorized fluorescence stereomicroscope Leica MZ16 FA	M1-116-5
Leica FluoCombi III™ for Leica fluorescence stereomicroscopes	M1-166-2
Leica StereoZoom® Greenough Stereomicroscopes	M1-188-0
Leica S8 APO StereoZoom®, natural science	M1-188-3
Leica S8 APO StereoZoom®, technology	M1-188-4
Zoom systems Leica Z6 APO and Z16 APO	M1-416-0
Motorized zoom systems Leica Z6 APO A & Z16 APO A	M1-417-0
Leica MacroFluo™ fluorescence macroscope	M1-416-2
Leica HL-RC™ high-performance transmitted light stand with Rottermann Contrast™ technology	M1-216-2
Leica MATS heating stages	M1-227-0
Leica L2 cold light source	M1-288-0
Leica L5 FL cold light fluorescence system	M1-205-1
Leica ErgoModules®	M1-215-2
Leica IC A video module for Leica M stereomicroscopes	M1-393-1
Leica ICC A video module for Leica M stereomicroscopes	M1-393-2
Leica MPS30 photoautomat	M1-330-0
Leica MPS60 photoautomat	M1-360-0
Leica colposcope	M1-280-0
Swing arm stands	M1-217-1

## Digital cameras & image processing/analysis software

Leica ICD Integrated digital camera	M1-393-4
3D display system: Leica IC 3D, StereoExplorer, ASD-3D-Display	M1-525-5
Leica DFC280 FireWire color camera system	M1-398-2
Leica DFC300 FX FireWire color camera system	M1-398-1
Leica DFC320 FireWire color camera system	M1-398-6
Leica DFC350 FX FireWire monochrome camera system	M1-397-8
Leica DFC480 High-performance FireWire camera system	M1-398-8
Leica DC500 High-resolution 12-megapixel camera	M1-398-3
Leica DC150 Digital camera system	M1-398-4
Leica IM1000 Image Manager image management system	M1-502-0
Leica QWin for quantitative microscopy	M1-511-0
Leica Q550MW	M1-555-0
LAS Image Overlay	M1-525-1
LAS Multifocus	M1-525-2
LAS Reticule	M1-525-3

# Leica Microsystems – the brand for outstanding products

Leica Microsystems' mission is to be the world's first-choice provider of innovative solutions to our customers' needs for vision, measurement, lithography and analysis of microstructures.

Leica, the leading brand for microscopes and scientific instruments, developed from five brand names, all with a long tradition: Wild, Leitz, Reichert, Jung and Cambridge Instruments. Yet Leica symbolizes innovation as well as tradition.

## Leica Microsystems – an international company with a strong network of customer services

Australia:	Gladesville, NSW	Tel. +1 800 625 286	Fax +61 2 9817 8358
Austria:	Vienna	Tel. +43 1 486 80 50 0	Fax +43 1 486 80 50 30
Canada:	Richmond Hill/Ontario	Tel. +1 905 762 20 00	Fax +1 905 762 89 37
China:	Hong Kong	Tel. +8522 564 6699	Fax +8522 564 4163
Denmark:	Herlev	Tel. +45 44 5401 01	Fax +45 44 5401 11
France:	Rueil-Malmaison Cédex	Tel. +33 1 4732 8585	Fax +33 1 4732 8586
Germany:	Bensheim	Tel. +49 6251 1360	Fax +49 6251 136 155
Italy:	Milan	Tel. +39 02 57 486 1	Fax +39 02 5740 3273
Japan:	Tokyo	Tel. +81 3 543 596 09	Fax +81 3 543 596 15
Korea:	Seoul	Tel. +82 2 514 6543	Fax +82 2 514 6548
Netherlands:	Rijswijk	Tel. +31 70 41 32 130	Fax +31 70 41 32 109
Portugal:	Lisbon	Tel. +35 1 213 814 766	Fax +35 1 213 854 668
Singapore:		Tel. +65 6 77 97 823	Fax +65 6 77 30 628
Spain:	Barcelona	Tel. +34 93 494 9530	Fax +34 93 494 9532
Sweden:	Sollentuna	Tel. +46 8 625 45 45	Fax +46 8 625 45 10
Switzerland:	Glattbrugg	Tel. +41 44 809 34 34	Fax +41 44 809 34 44
United Kingdom:	Milton Keynes	Tel. +44 1908 246 246	Fax +44 1908 609 992
USA:	Bannockburn/Illinois	Tel. +1 800 248 0123	Fax +1 847 405 0164

and representatives of Leica Microsystems  
in more than 100 countries.

In accordance with the ISO 9001 certificate, Leica Microsystems (Switzerland) Ltd, Business Unit Stereo & Microscope Systems has at its disposal a management system that meets the requirements of the international standard for quality management. In addition, production meets the requirements of the international standard ISO 14001 for environmental management.

The companies of the Leica Microsystems Group operate internationally in four business segments, where we rank with the market leaders.

### • Microscopy Systems

Our expertise in microscopy is the basis for all our solutions for visualization, measurement and analysis of microstructures in life sciences and industry. With confocal laser technology and image analysis systems, we provide three-dimensional viewing facilities and offer new solutions for cytogenetics, pathology and materials sciences.

### • Specimen Preparation

We provide comprehensive systems and services for clinical histo- and cytopathology applications, biomedical research and industrial quality assurance. Our product range includes instruments, systems and consumables for tissue infiltration and embedding, microtomes and cryostats as well as automated stainers and coverslippers.

### • Medical Equipment

Innovative technologies in our surgical microscopes offer new therapeutic approaches in microsurgery.

### • Semiconductor Equipment

Our automated, leading-edge measurement and inspection systems and our E-beam lithography systems make us the first choice supplier for semiconductor manufacturers all over the world.

[www.stereomicroscopy.com](http://www.stereomicroscopy.com)

Leica Microsystems (Switzerland) Ltd  
Stereo & Microscope Systems  
CH-9435 Heerbrugg

Telephone +41 71 726 33 33  
Fax +41 71 726 33 99  
[www.leica-microsystems.com](http://www.leica-microsystems.com)  
[www.stereomicroscopy.com](http://www.stereomicroscopy.com)

**Leica**  
MICROSYSTEMS

# Leica Microsystems – the brand for outstanding products

Leica Microsystems' mission is to be the world's first-choice provider of innovative solutions to our customers' needs for vision, measurement, lithography and analysis of microstructures.

Leica, the leading brand for microscopes and scientific instruments, developed from five brand names, all with a long tradition: Wild, Leitz, Reichert, Jung and Cambridge Instruments. Yet Leica symbolizes innovation as well as tradition.

## Leica Microsystems – an international company with a strong network of customer services

Australia:	Gladesville, NSW	Tel. +1 800 625 286	Fax +61 2 9817 8358
Austria:	Vienna	Tel. +43 1 486 80 50 0	Fax +43 1 486 80 50 30
Canada:	Richmond Hill/Ontario	Tel. +1 905 762 20 00	Fax +1 905 762 89 37
China:	Hong Kong	Tel. +8522 564 6699	Fax +8522 564 4163
Denmark:	Herlev	Tel. +45 44 5401 01	Fax +45 44 5401 11
France:	Rueil-Malmaison Cédex	Tel. +33 1 4732 8585	Fax +33 1 4732 8586
Germany:	Bensheim	Tel. +49 6251 1360	Fax +49 6251 136 155
Italy:	Milan	Tel. +39 02 57 486 1	Fax +39 02 5740 3273
Japan:	Tokyo	Tel. +81 3 543 596 09	Fax +81 3 543 596 15
Korea:	Seoul	Tel. +82 2 514 6543	Fax +82 2 514 6548
Netherlands:	Rijswijk	Tel. +31 70 41 32 130	Fax +31 70 41 32 109
Portugal:	Lisbon	Tel. +35 1 213 814 766	Fax +35 1 213 854 668
Singapore:		Tel. +65 6 77 97 823	Fax +65 6 77 30 628
Spain:	Barcelona	Tel. +34 93 494 9530	Fax +34 93 494 9532
Sweden:	Sollentuna	Tel. +46 8 625 45 45	Fax +46 8 625 45 10
Switzerland:	Glattbrugg	Tel. +41 44 809 34 34	Fax +41 44 809 34 44
United Kingdom:	Milton Keynes	Tel. +44 1908 246 246	Fax +44 1908 609 992
USA:	Bannockburn/Illinois	Tel. +1 800 248 0123	Fax +1 847 405 0164

and representatives of Leica Microsystems  
in more than 100 countries.

In accordance with the ISO 9001 certificate, Leica Microsystems (Switzerland) Ltd, Business Unit Stereo & Microscope Systems has at its disposal a management system that meets the requirements of the international standard for quality management. In addition, production meets the requirements of the international standard ISO 14001 for environmental management.

The companies of the Leica Microsystems Group operate internationally in four business segments, where we rank with the market leaders.

### • Microscopy Systems

Our expertise in microscopy is the basis for all our solutions for visualization, measurement and analysis of microstructures in life sciences and industry. With confocal laser technology and image analysis systems, we provide three-dimensional viewing facilities and offer new solutions for cytogenetics, pathology and materials sciences.

### • Specimen Preparation

We provide comprehensive systems and services for clinical histo- and cytopathology applications, biomedical research and industrial quality assurance. Our product range includes instruments, systems and consumables for tissue infiltration and embedding, microtomes and cryostats as well as automated stainers and coverslippers.

### • Medical Equipment

Innovative technologies in our surgical microscopes offer new therapeutic approaches in microsurgery.

### • Semiconductor Equipment

Our automated, leading-edge measurement and inspection systems and our E-beam lithography systems make us the first choice supplier for semiconductor manufacturers all over the world.

[www.stereomicroscopy.com](http://www.stereomicroscopy.com)

Leica Microsystems (SEA) Pte. Ltd.  
67 Ayer Rajah Crescent #07-23  
Ayer Rajah Industrial Estate  
Singapore 139950

Telephone +65 6 77 97 823  
Fax +65 6 77 30 628  
[www.leica-microsystems.com](http://www.leica-microsystems.com)

**Leica**  
MICROSYSTEMS

# Leica Microsystems – the brand for outstanding products

Leica Microsystems' mission is to be the world's first-choice provider of innovative solutions to our customers' needs for vision, measurement, lithography and analysis of microstructures.

Leica, the leading brand for microscopes and scientific instruments, developed from five brand names, all with a long tradition: Wild, Leitz, Reichert, Jung and Cambridge Instruments. Yet Leica symbolizes innovation as well as tradition.

## Leica Microsystems – an international company with a strong network of customer services

Australia:	Gladesville, NSW	Tel. +1 800 625 286	Fax +61 2 9817 8358
Austria:	Vienna	Tel. +43 1 486 80 50 0	Fax +43 1 486 80 50 30
Canada:	Richmond Hill/Ontario	Tel. +1 905 762 20 00	Fax +1 905 762 89 37
China:	Hong Kong	Tel. +8522 564 6699	Fax +8522 564 4163
Denmark:	Herlev	Tel. +45 44 5401 01	Fax +45 44 5401 11
France:	Rueil-Malmaison Cédex	Tel. +33 1 4732 8585	Fax +33 1 4732 8586
Germany:	Bensheim	Tel. +49 6251 1360	Fax +49 6251 136 155
Italy:	Milan	Tel. +39 02 57 486 1	Fax +39 02 5740 3273
Japan:	Tokyo	Tel. +81 3 543 596 09	Fax +81 3 543 596 15
Korea:	Seoul	Tel. +82 2 514 6543	Fax +82 2 514 6548
Netherlands:	Rijswijk	Tel. +31 70 41 32 130	Fax +31 70 41 32 109
Portugal:	Lisbon	Tel. +35 1 213 814 766	Fax +35 1 213 854 668
Singapore:		Tel. +65 6 77 97 823	Fax +65 6 77 30 628
Spain:	Barcelona	Tel. +34 93 494 9530	Fax +34 93 494 9532
Sweden:	Sollentuna	Tel. +46 8 625 45 45	Fax +46 8 625 45 10
Switzerland:	Glattbrugg	Tel. +41 44 809 34 34	Fax +41 44 809 34 44
United Kingdom:	Milton Keynes	Tel. +44 1908 246 246	Fax +44 1908 609 992
USA:	Bannockburn/Illinois	Tel. +1 800 248 0123	Fax +1 847 405 0164

and representatives of Leica Microsystems  
in more than 100 countries.

In accordance with the ISO 9001 certificate, Leica Microsystems (Switzerland) Ltd, Business Unit Stereo & Microscope Systems has at its disposal a management system that meets the requirements of the international standard for quality management. In addition, production meets the requirements of the international standard ISO 14001 for environmental management.

The companies of the Leica Microsystems Group operate internationally in four business segments, where we rank with the market leaders.

### • Microscopy Systems

Our expertise in microscopy is the basis for all our solutions for visualization, measurement and analysis of microstructures in life sciences and industry. With confocal laser technology and image analysis systems, we provide three-dimensional viewing facilities and offer new solutions for cytogenetics, pathology and materials sciences.

### • Specimen Preparation

We provide comprehensive systems and services for clinical histo- and cytopathology applications, biomedical research and industrial quality assurance. Our product range includes instruments, systems and consumables for tissue infiltration and embedding, microtomes and cryostats as well as automated stainers and coverslippers.

### • Medical Equipment

Innovative technologies in our surgical microscopes offer new therapeutic approaches in microsurgery.

### • Semiconductor Equipment

Our automated, leading-edge measurement and inspection systems and our E-beam lithography systems make us the first choice supplier for semiconductor manufacturers all over the world.

[www.stereomicroscopy.com](http://www.stereomicroscopy.com)

Leica Microsystems  
Viale Ortles, 54/A  
IT-20139 Milano

Tel. +39 02 57 486.1  
Fax +39 02 57 40 3273  
[www.leica-microsystems.com](http://www.leica-microsystems.com)  
[www.stereomicroscopy.com](http://www.stereomicroscopy.com)

**Leica**  
MICROSYSTEMS