



Leica Stereo- Fluorescence Systems

User Manual

	Page
Leica MZ10 F	
fluorescence stereomicroscope	
Description.....	4
Safety concept.....	4
Fluorescence applications.....	6
Components, controls.....	8
Sets of filters.....	9
Assembly	
Overview.....	10
Focusing drive, microscope carrier, MZ10 F optics carrier.....	11
UV protection screen.....	11
Model 106Z lamp housing.....	12
Mercury-vapour lamps.....	12
Stray-light protection.....	13
Collector, heat-protection filter.....	13
Supply units.....	14
Adjusting the mercury-vapour lamp.....	15
Operation	
FLUOIII™ filter system, light stop.....	16
Adjusting the dioptric setting, focusing, observing.....	17
Leica stereo-fluorescence module	
Components, controls.....	18
Sets of filters.....	19
Assembly	
Overview.....	20
Focusing drive, microscope carrier, optics carrier.....	21
Fluorescence module.....	21
Sets of filters.....	21
UV protection screen.....	22
Model 106Z lamp housing.....	12
Mercury-vapour lamps.....	12
Stray-light protection.....	13
Collector, heat-protection filter.....	13
Supply units.....	14
Adjusting the mercury-vapour lamp.....	15
Operation	
Filter changer, light stop, double-iris diaphragm.....	23
Adjusting the dioptric setting, focusing, observing.....	23

Description

Fluorescence technique

Some substances fluoresce when irradiated with short-wave light. This property is utilized in the fluorescence technique, in which certain structures and features which do not fluoresce can be tagged with a fluorescing dye. An example is green-fluorescing protein (GFP), which is used in molecular biology.

Stereo-fluorescence

With Leica fluorescence systems you can complete unprepared fluorescing specimens to be non-destructively studied in three dimensions, manipulated, sorted and recorded. The intense light emitted by the mercury-vapour burner, used in conjunction with selected filter sets, enables even the finest structures to be differentiated and expands the amount of information revealed by the incident-light fluorescence technique.

Fluorescence stereomicroscope

The Leica MZ10 F with 10:1 zoom is the routine stereomicroscope for fluorescence applications. The patented separate beam path (TriBeam™) for the fluorescence illuminator and the patented filter system (FLUOIII™) together produce excellent fluorescence images.

Stereo-fluorescence module

The stereo-fluorescence modul can be combined with the Leica stereomicroscope models MS5, MZ6, MZ7.5, MZ9.5, MZ12.5, MZ16, and with older models.

User manual

The present user manual describes only the functions of the fluorescence illuminator, the use of the filter sets, and the fitting of the fluorescence module. For detailed information about the use of the stereomicroscope, its care and its safety, please refer to those sections of the separate manual M2-105-0EN which relate to the Leica MZ12.5 with 12.5:1 zoom.

Safety concept

Before you set up the instrument and before you fit the fluorescence illuminator, read:

- this user manual, observing the notes relating to safety
- the user manual for your stereomicroscope, observing the notes relating to safety and care.

Permitted uses

Leica stereo-fluorescence systems are equipped with a special fluorescence illuminator. They are intended for the three-dimensional observation of fluorescing objects. They consist of:

- a stereomicroscope with stand, binocular tube and eyepieces
- an integrated FLUOIII filter system (for MZ10 F) or a separate stereo-fluorescence module
- appropriate filter sets with barrier- and excitation filters, a light stop, and individually-selectable filters
- a UV protection screen
- a lamp housing with high-pressure mercury vapour burner
- a supply unit with power cable.

Prohibited uses

The use of Leica stereo-fluorescence systems in a different manner from that described in this user manual can lead to injury, malfunction and damage.

- Do not fit different plugs or cables
- Do not dismantle or modify components unless instructions for doing so are given in the user manual
- Components may only be opened by authorized personnel.

Place of use

Leica stereo-fluorescence systems are intended for use in closed rooms and may not be used outdoors.

Responsibilities of person in charge of instrument

- Ensure that the Leica stereo-fluorescence systems are operated, maintained and repaired only by authorized and trained personnel
- Ensure that personnel who use the instrument have read and understood this user manual and in particular all safety instructions.

Servicing and repairs

- Repairs may only be carried out by Leica-trained service technicians or by technical personnel authorized to do so by the person in charge of the instrument
- Only original Leica spare parts may be used
- Unplug the power cable before opening the supply unit. Touching live circuits can cause injury.

Legal requirements

Adhere to general and local regulations relating to accident prevention and environmental protection.

Conformity with European Community directive

Leica stereo-fluorescence systems and their accessories are constructed in accordance with the latest technologies and are provided with a statement of conformity with EC requirements.

Light source: Safety regulations

Safety measures introduced by manufacturer

- UV protection screen in front of the specimen plane prevents direct UV radiation from reaching the eyes.
- Dummy filter carriers in the unoccupied positions of the rapid filter changer prevent direct UV radiation from reaching the eyes
- UV filters in the observation beam paths protect the eyes against UV radiation.
- Stray-light protection on the underside of the lamp housing protects the user's hands against UV radiation.

Warning

UV can damage your eyes. Therefore:

- Never look at the light spot on the specimen plane without the UV protection screen in position
- Never look into the eyepieces unless there is an excitation filter in the beam path
- Always keep dummy filter carriers in the unoccupied positions of the rapid filter changer (for MZ10 F)
- Do not place the specimen on a white or highly-reflective background.

Supply unit

- Pull the power plug of the supply unit out from the power socket:
 - when assembling and dismantling the lamp housing
 - before opening the lamp housing
- when changing the mercury-vapour burner and other components such as the heat-protection filter or the collector
- when servicing the supply unit

Lamp housing

- Never open the lamp housing while the burner is switched on (risk of explosion, UV irradiation, dazzling)
- Always allow the lamp housing to cool for at least 15 minutes before opening it (risk of burner exploding)
- Never cover the ventilator slots on the lamp housing (risk of fire)

Mercury-vapour lamp

- Read the user manual and safety directions provided by the manufacturer of the mercury-vapour burner, and particularly those relating to its breakage and to the release of mercury
- Before transporting the equipment, remove the mercury-vapour burner and place it in its original packaging. Use the transport peg in place of the burner, to secure movable parts within the lamp housing
- When the mercury-vapour burner has reached the end of its nominal working life as indicated by the manufacturer's information and the time counter on the supply unit, change the discoloured burner (increased risk of explosion)
- Leica declines all responsibility for injury and damage resulting from exploding, incorrectly-fitted or incorrectly-used mercury-vapour burners.

Applications

Natural science	Application	Fluorescence filter set
Anatomy	<ul style="list-style-type: none"> • Monitoring of capillary flow 	<ul style="list-style-type: none"> • GFP 1, GFP 2
Biology	<ul style="list-style-type: none"> • Gene expression in chicken embryos, fruit flies, threadworms and zebra fish • Fish otoliths marked with alizarine red • Genetic expression through viruses and bacteria which infect plants and animals 	<ul style="list-style-type: none"> • GFP 1, GFP 2 • Green • GFP 2
Biomedicine	<ul style="list-style-type: none"> • Humatic seals on pacemakers 	<ul style="list-style-type: none"> • Blue, green
Genetics	<ul style="list-style-type: none"> • Cellular detection and protein expression • Sorting and dissection • Monitoring developmental processes 	<ul style="list-style-type: none"> • GFP 1, GFP 2
Neurology	<ul style="list-style-type: none"> • Gap junctions on muscles and nerves 	<ul style="list-style-type: none"> • GFP 1, violet
Ophthalmology	<ul style="list-style-type: none"> • Cell development in rats' eyes 	<ul style="list-style-type: none"> • GFP 1, GFP 2
Pharmacy	<ul style="list-style-type: none"> • Drugs • ELI spotting in cell structures • Monitoring of capillary flow with FITC 	<ul style="list-style-type: none"> • GFP 1, GFP 2 • Green • GFP 2
Plants and seeds	<ul style="list-style-type: none"> • Plants, genetic expression, transgenetics • Bacteria detection 	<ul style="list-style-type: none"> • GFP 1, GFP 2
Botany	<ul style="list-style-type: none"> • Plant cells, plant surfaces, soil samples 	<ul style="list-style-type: none"> • GFP 3
Hydrology	<ul style="list-style-type: none"> • Water quality (bacterial and other pollutants) • Filtered water • Cell structures in and on the filter membrane 	<ul style="list-style-type: none"> • UV • GFP 1 • GFP 1
Parasitology	<ul style="list-style-type: none"> • Detection of bacteria on ticks 	<ul style="list-style-type: none"> • GFP 1, GFP 2
Forestry	<ul style="list-style-type: none"> • Development of environmentally-acceptable methods of pest control (investigation of viruses on pests) 	<ul style="list-style-type: none"> • GFP 1

Industry	Application	Fluorescence filter set
Electronics	<ul style="list-style-type: none"> • Solder paste on SMDs • Epoxy resin on SMD plates • Luminescent coating of TV monitor tubes • Quality of polymer castings for embedding integrated circuits 	<ul style="list-style-type: none"> • GFP 1, GFP 2 • GFP 1, GFP 2 • GFP 1, GFP 2 • Violet
Semiconductors	<ul style="list-style-type: none"> • Positive photo resists (OCG HPR 504) • Negative photo resists • Detection of foreign particles on masks, wafers and subassemblies 	<ul style="list-style-type: none"> • GFP 1, green • Blue • UV, GFP 1, GFP 2 • Violet
Petrochemicals	<ul style="list-style-type: none"> • Oil inspection 	<ul style="list-style-type: none"> • GFP 1
Polymers	<ul style="list-style-type: none"> • Detection of foreign particles • Identification of non-polymerized parts • Examination of beads (polymer pellets used in chemical measurements and analyses) 	<ul style="list-style-type: none"> • Blue • UV • GFP 1, GFP 2
Engineering	<ul style="list-style-type: none"> • Inspection of cemented areas on mechanical or optical components 	<ul style="list-style-type: none"> • GFP 1, violet
Metalworking industries	<ul style="list-style-type: none"> • Cracks and surface defects • Detection of contamination on components • Quality control of welds • Fracture analysis 	<ul style="list-style-type: none"> • GFP 1
Materials science	<ul style="list-style-type: none"> • Cracks, fractures, welds • Carbon bonding materials; fractures and orientation of carbon fibres 	<ul style="list-style-type: none"> • GFP 1 • Violet
Bitumen	<ul style="list-style-type: none"> • Quality control for tar and bitumen 	<ul style="list-style-type: none"> • GFP 1
Concrete	<ul style="list-style-type: none"> • Cracks and pores 	<ul style="list-style-type: none"> • GFP 1
Papermaking	<ul style="list-style-type: none"> • Coating of paper fibres • Investigation of inclusions 	<ul style="list-style-type: none"> • GFP 1 • Violet
Forensic work	<ul style="list-style-type: none"> • Textile fibres, fingerprints, banknotes, forgeries, body fluids 	<ul style="list-style-type: none"> • GFP 1, GFP 2
Art restoration	<ul style="list-style-type: none"> • Pigments, forgeries 	<ul style="list-style-type: none"> • UV
Gemmology	Quality, value, inclusions	<ul style="list-style-type: none"> • Blue

Overview

Leica MZ10 F: Its components and controls

1. Choice of stand and of focusing drive (manual or motor-driven)
2. Microscope carrier for Leica MZ10 F
- 3a. Leica MZ10 F optics carrier with third beam path
- 3b. Integrated FLUOIII filter system
- 3c. Adapter for light source
- 3d. Rapid filter changer for any of four sets of filters
- 3e. Slots for light stop and for filter slide with individually-selectable filter
- 4a. Leica 106Z lamp housing for 50W or 100W high-pressure mercury vapour burners
- 4b. Stray-light protection
5. Supply units for 106Z lamp housing (not illustrated)
6. UV protection screen with arm
7. Double-iris diaphragm (optional)
8. Choice of binocular tube, or video-/phototube (optional)

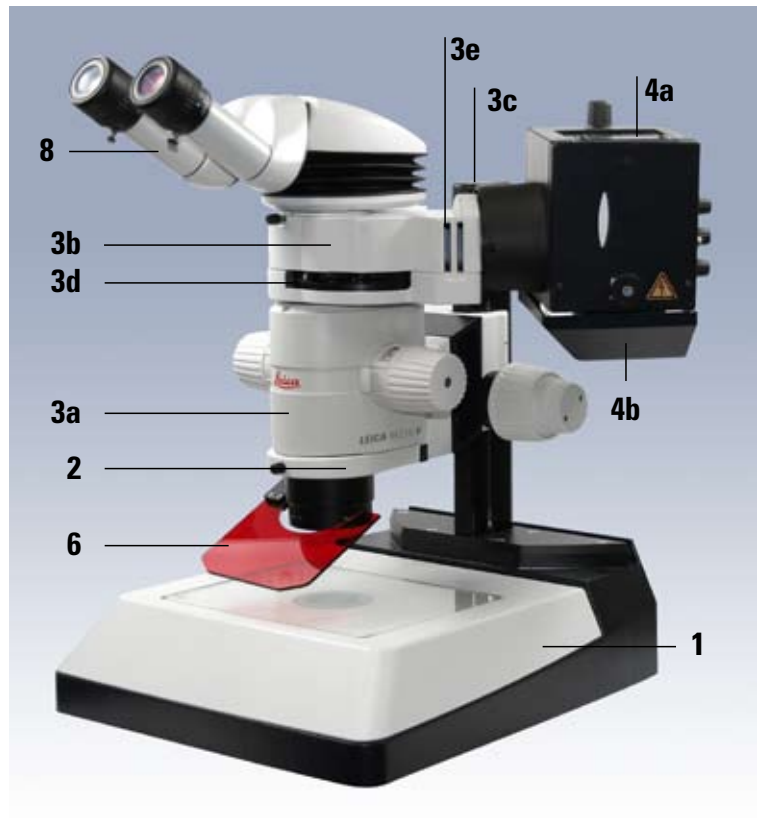

Filter sets for Leica MZ10 F

Filter sets	Designation	Excitation filter	Barrier filter
GFP fluorescence	GFP1	425/60 nm	480 nm
GFP Plus fluorescence	GFP2	480/40 nm	510 nm
GFP plant fluorescence	GFP3	470/40 nm	525/50
UV fluorescence	UV	360/40 nm	420 nm
Violet fluorescence	V	425/40 nm	475 nm
Blue fluorescence	B	470/40 nm	515 nm
Green fluorescence	G	546/10 nm	590 nm
Filter carrier, empty			

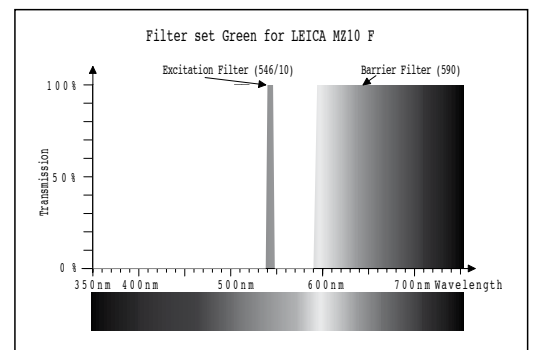
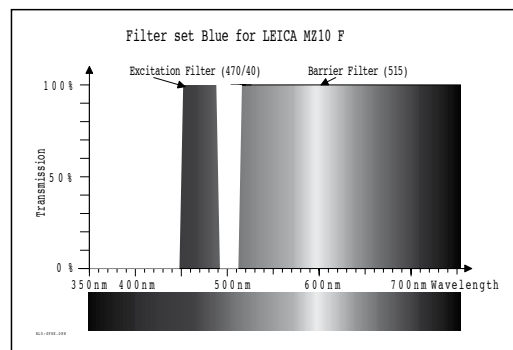
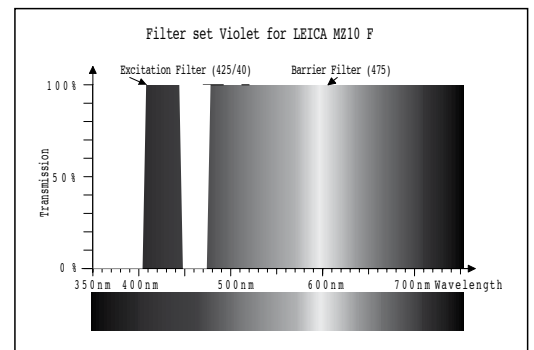
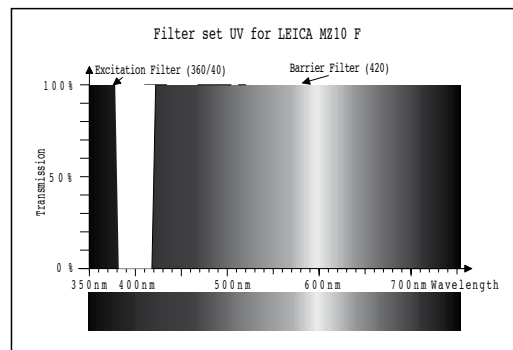
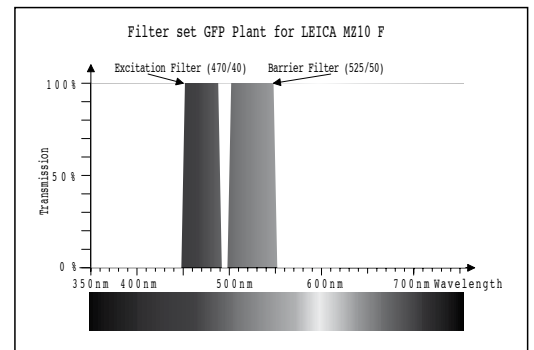
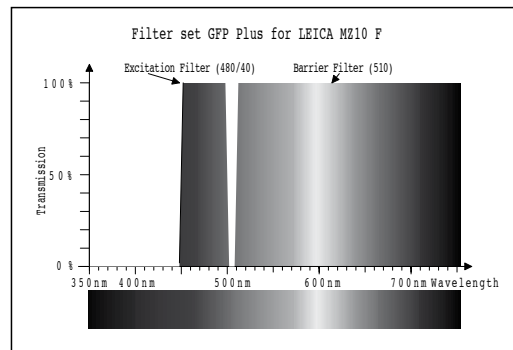
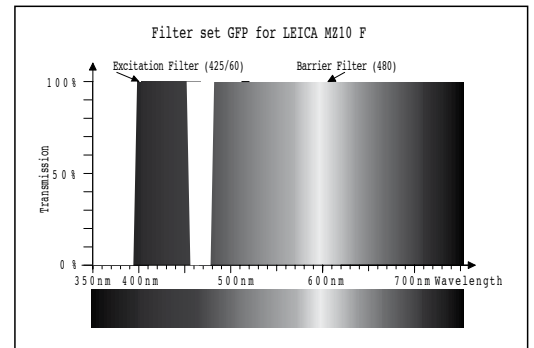

Leica MZ10 F

Assembly

1. Incident- or transmitted-light base
- 2a. Manual focusing drive, or
- 2b. Motorized focusing drive
3. Microscope carrier for Leica MZ10 F
4. Leica MZ10 F optics carrier with FLUOIII™ filter system
- 5a. Lamp housing 106Z
- 5b. Stray-light protection
6. Binocular tube
7. UV protection screen with arm
8. 4 sets of filters
9. Light stop
10. Filter slide for an individually-selectable filter
11. Double-iris diaphragm (optional)
12. Trinocular tube

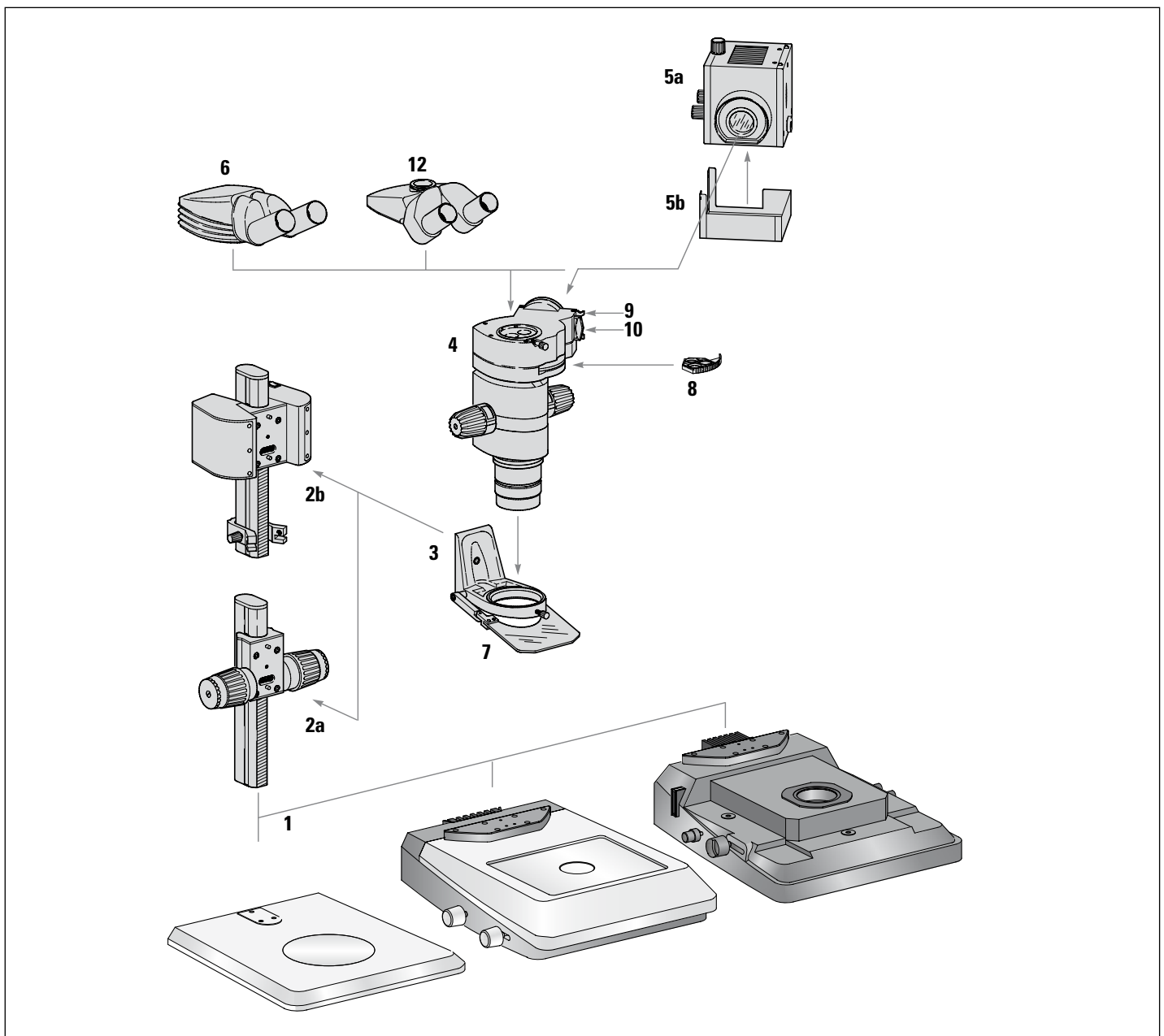

Leica MZ10 F

Focusing drive → base of stand

- ▶ Connect manually-operated or motor-driven focusing drive, complete with column, to base, as described in user manual M2-105-0EN.



Before using the motor focus, you must read the safety directions in the accompanying user manual M2-267-104.

Microscope carrier → focusing drive

- ▶ Fit microscope carrier of Leica MZ10 F to focusing drive in accordance with user manual M2-105-0EN.

Optics carrier → microscope carrier

The Leica MZ10 F optics carrier and the FLUOIII filter system form a single unit which was factory-adjusted. Do not try to dismantle it.

- ▶ Fit the Leica MZ10 F optics carrier to the microscope carrier in accordance with the user manual M2-105-0EN.

Additional components

- ▶ Fit the remaining components, such as binocular tube, eyepieces and optional double-iris diaphragm, to the FLUOIII filter system in accordance with user manual M2-105-0EN.

Video-/phototube

To permit shorter exposure times in fluorescence photography, we recommend you to use the video-/phototube HDV with 100% light in the video-/photo beam path.

Double-iris diaphragm

The double-iris diaphragm is used to increase the depth of field (see user manual M2-105-0EN).

- ▶ Fit the double-iris diaphragm to the FLUOIII filter system.

UV protection screen → microscope carrier

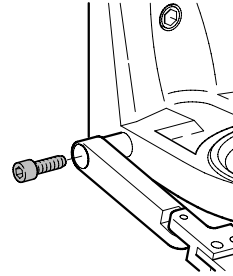

- ▶ Using a hollow screw, fit the UV protection screen to the microscope carrier on either the left or the right.



Always position the UV protection screen so that the user can never look directly at the light spot (see page 4):

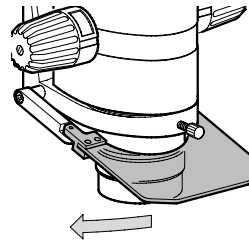

- ▶ Fit the UV protection screen with arm, at the side.

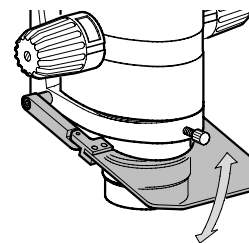

- ▶ Release the hollow screw.
- ▶ Adjust the UV protection screen, upwards or downwards.
- ▶ Tighten the hollow screw.

Assembly

Lamp housing

The Leica 106Z lamp housing is equipped.
For information about the supply units for the 106Z lamp housing, see page 14.
Model 105Z lamp housings, if available, can also be used.



Observe the safety regulations on page 5

Notes and recommendations

- Do not switch on and off more than necessary, because this will shorten the burner life
- Hot mercury-vapour burners cannot be ignited again until after they have cooled
- If possible, burn-in new mercury-vapour burners by running them continuously for one or two hours
- Be very careful when fitting the burner.
Do not apply pressure, as it breaks easily
- Never touch the glass envelope of the burner with your fingers. Fingerprints later burn in and reduce the light quality. If necessary, carefully remove fingerprints and dust using a cloth damped with alcohol and then wipe dry.

Fitting and changing the mercury-vapour burner

For the 106Z lamp housing, use the 100W mercury-vapour burner type 307-072.057 or the 50W burner.

The mercury-vapour burner is supplied in a separate package.

- Units which are unmarked or are marked L1 are for lower currents and higher voltages.
- Units marked L2 are for higher currents and lower voltages (see page 14).

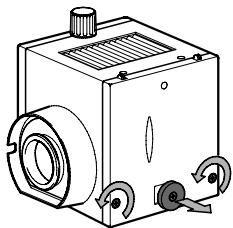

- ▶ Slacken the two Phillips screws
- ▶ Pull the disconnect plug slightly out without turning it

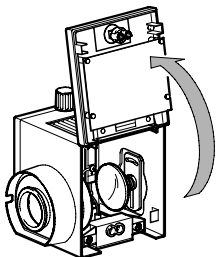

- ▶ Flip open the cover

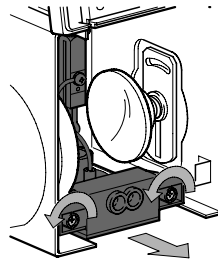

- ▶ Slacken the Phillips screws
- ▶ Carefully extract the socket, complete with burner mount and connecting cable

- ▶ Slacken the slit-headed screws
- ▶ Remove the transport peg and keep it for subsequent transport
- ▶ Dispose of old mercury-vapour burners in accordance with environmental regulations.

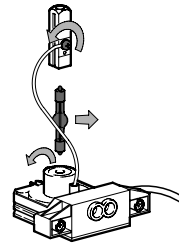

- When a new mercury-vapour burner is fitted, the inscription on the metal mount must be upright.
- ▶ Carefully insert the mercury-vapour burner into the lower mount
- ▶ For mercury-vapour burners with seal point: Turn these so that the seal point is at the side of the beam path
- ▶ Carefully position the flexible power cable on the upper metal mount of the mercury-vapour burner.

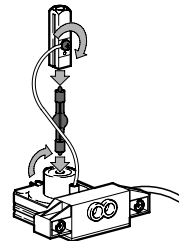

- ▶ Tighten the upper and lower screws with great care

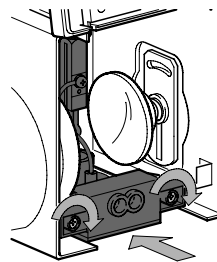

- ▶ Introduce the burner mount, complete with burner, into the rail of the lamp housing.
- ▶ Tighten the screws

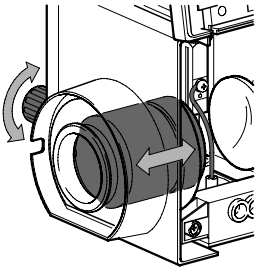

- ▶ Using the focusing knob, displace the collector:
- During this movement, the collector must not touch the flexible power cable. If necessary, bend the cable away

- ▶ Carefully close the lamp housing, making sure that the disconnect plug engages the socket
- ▶ Press in the disconnect plug slightly
- ▶ Tighten the screws
- ▶ Push the disconnect plug fully in to the stop without turning it.

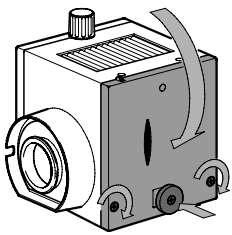

Lamp housing assemble

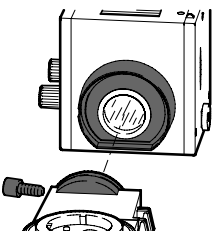

- ▶ Using the Allen key, release the hollow screw
- ▶ Introduce the lamp housing into the adapter of the fluorescence module and tighten the hollow screw.

Stray-light protection

There are slots in the lamp housing through which UV light can shine on the user's hands during manipulations beneath the housing. The stray-light protection on the underside of the lamp housing is designed to block this light.

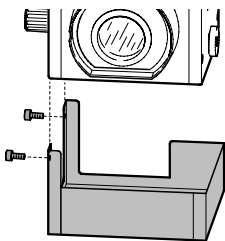

- ▶ Secure the stray-light protection with two screws.

Removing the collector and the heat-protection filter

The collector and the heat-protection filter can be removed for cleaning or if defective.

- ▶ Open the lamp housing as described on page 12 and remove the burner socket

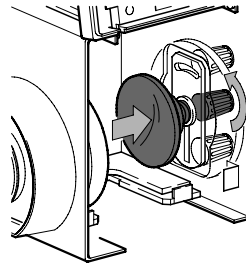

- ▶ Move the reflector fully to the right-hand stop

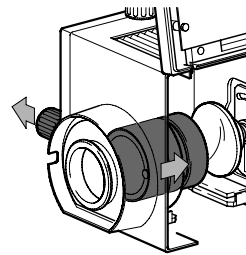

- ▶ Hold the collector and pull out the focusing knob
- ▶ Extract the collector

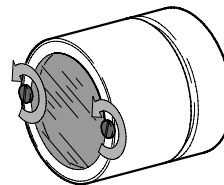

- ▶ Slacken the two screws and remove the heat-protection filter from the collector
- ▶ Screw a new heat-protection filter into position

Replacing the collector

- ▶ Pull out the focusing knob
- ▶ Carefully replace the collector and move it to the left until the focusing knob engages the guide groove
- ▶ Test the displacement of the collector
- ▶ Refit the burner socket (page 12) and close the lamp housing.

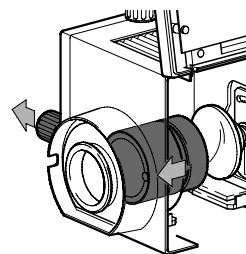

Assembly

Supply unit for lamp housing 106Z with 50W mercury-vapour burner

1. On/off switch
2. Running-time meter
3. Selector for L1/L2 burners
4. Fuse
5. Selector for 50Hz/60Hz
6. Connector for lamp
7. Power cable

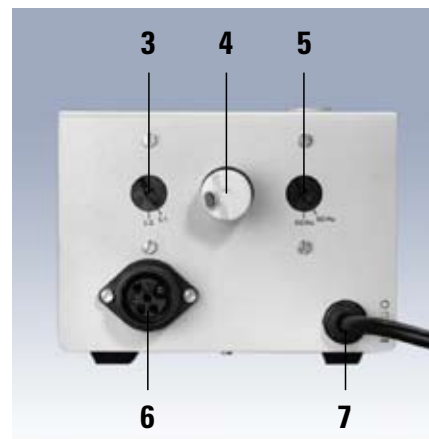
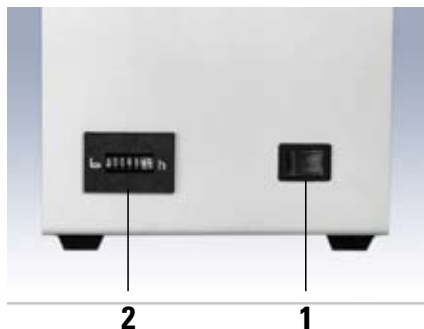

The supply unit is intended for power supplies above 220V. To run it on lower voltages a step-down transformer is required (e.g. 230V to 110V).



Observe the safety regulations on page 5.

- ▶ Connect the cable from the lamp housing to the supply unit
- ▶ Engage "L1" or "L2" in accordance with the inscription on the burner socket (see page 12)
- ▶ Engage 50Hz or 60Hz
- ▶ Connect the power cable to the supply unit and to the grid
- ▶ Make a note of the running-time meter reading.

Input type
220V/240V $\pm 10\%$
220V ~50/60Hz
Hg50W L1/L2
Osram no. 0-958
Max. power 320VA

Supply unit for lamp housing 106Z with 100W mercury-vapour burner

1. On/off switch
2. Pilot lamp LAMP
3. Pilot lamp TEMP
4. Running-time meter
5. Pilot lamp SAFETY



Observe the safety regulations on page 5

- ▶ Connect the cable from the lamp housing to the supply unit
- ▶ Secure the lamp cable.
- ▶ Connect the power cable to the supply unit and to the grid
- ▶ Make a note of the running-time meter reading.



Type	ebq 100dc
Input voltage	90V to 250V AC, max 265VA
Input frequency	48Hz to 63 Hz
Protection class	IP20
Series no.	G 34240090

Fuses

The fuse holder is secured in the holder with spring clips on both sides.

- ▶ Insert a screwdriver behind the spring clips and extract the fuse holder.
- ▶ Insert the fuses (2x T3,15A H250V F1/F2).
- ▶ Refit the fuse holder

Adjusting the mercury vapour lamp

This adjustment is important for obtaining a uniform light spot and good-quality fluorescence.



While adjusting the mirror image, do not project light on to the electrodes for long periods (risk of explosion through overheating)

The two electrodes are imaged as an extension of the plane of symmetry of the discharge arc, but are difficult to see.

- ▶ Switch on the supply unit and wait for two or three minutes
 - The 100W supply unit emits a whistle
- ▶ Swing out the UV-light excluder (page 21)
- Work without the UV-light excluder is only permitted for adjustment, and then only for short periods
- ▶ Pull out the light stop (see page 16, MZ10 F and page 22, Fluorescence module).
- ▶ MZ10 F: Turn the filter set in the beam path (page 16).
- ▶ Stereo-fluorescence module: Insert the excitation filter (page 22).
- ▶ Mark a cross on a piece of paper and place it in the middle of the illuminated spot
- ▶ Select the lowest magnification

- The discharge arc is visible in the illuminated spot and lies at about 45° to the lines of the cross (fig. a)
- ▶ Look into the eyepieces and focus on the cross
- ▶ Using your unaided eye, observe the discharge arc on the paper and bring it into focus with the focusing knob (3) (fig. a)
- ▶ Using the positioning knobs (1 and 2), displace the discharge arc (fig. b)
- ▶ Bring the mirror image of the discharge arc into focus with the knob (6) and use the knobs 4 and 5 to position it symmetrically relative to the original image (fig. c)
- For the 50W burner, the discharge-arc image and its mirror image should touch
- For the 100W burner, the discharge-arc image and its mirror image should be superimposed.
- ▶ Using the focusing knob (3), readjust the illuminated field
- The illuminated field should now be large, circular and as uniform as possible
- ▶ Reposition the UV-light excluder correctly (page 21).

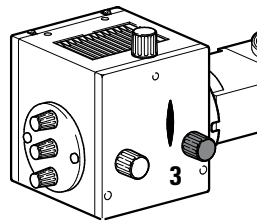

Figs. a: Bringing the discharge arc into focus

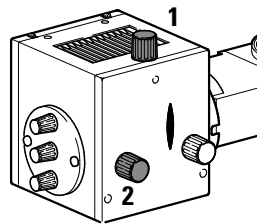

Figs. b: Positioning the discharge arc relative to the cross

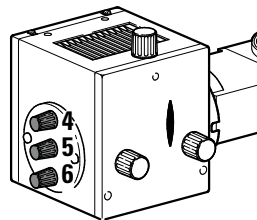

Figs. c: Focusing and positioning the mirror image of the discharge arc

Hg 50W

Hg 100W

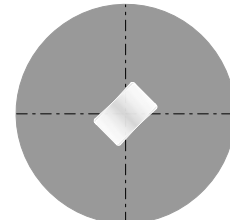
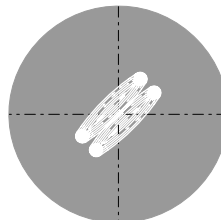
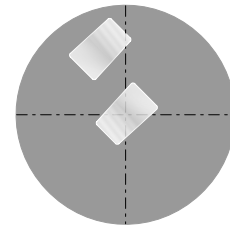
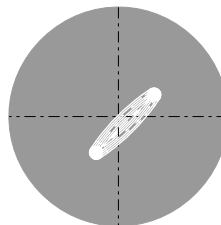
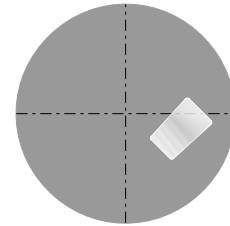
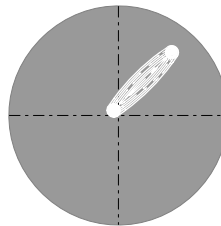

Leica MZ10 F

FLUOIII filter system

The filter system consists of a rapid filter changer for the barrier- and excitation filters and two slots for a light stop and for a filter slide respectively.

Rapid filter changer

The rapid filter changer of the Leica MZ10 F accepts a total of four sets of filters. These are inscribed (see table on page 9). Each filter set consists of two barrier filters for the observation beam paths and one excitation filter for the illumination beam path.

To avoid fingerprints on the filters in the filter sets, try to avoid touching them. If fingerprints do occur, remove them with a clean lint-free cloth and pure alcohol.

An empty filter carrier is available for individual filter combinations.

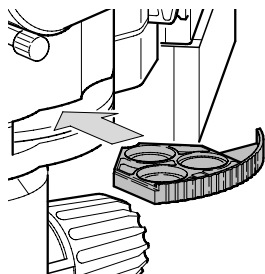

- ▶ Insert a set of filters into the rapid filter changer so that the inscription (e.g. GFP) is upright and on the right-hand side. Make sure that the shape of the filter set follows the shape of the instrument.

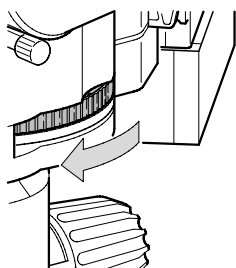

- ▶ Turn the filter set until it engages.
- ▶ Insert a total of four sets of filters, or insert dummy filter carriers if the number is less.



If you use less than four filter sets, you must insert in the free spaces the dummy filter carriers provided. If you leave spaces unfilled, you risk eye damage from direct UV radiation from the third beam path (see page 5).

Dummy filter carrier

In the dummy filter carrier there are two openings for the observation beam paths instead of the barrier filters. The third path has been closed. Use the dummy filter carrier:

- if you are using less than four sets of filters
- if you are working without the fluorescence illuminator for periods of up to 15 seconds.
- Do not use the dummy filter carrier to block the light from the mercury-vapour burner for more than 15 seconds, or it will heat up. Use the light stop instead.

Light stop

The FLUOIII filter system includes a slot for the light stop. In phases where the object is to be examined in e.g. transmitted light instead of under conditions of fluorescence, the light stop is used to block the illumination beam path so that the mercury-vapour burner does not have its life shortened by being switched on and off more than is absolutely necessary (see page 5).

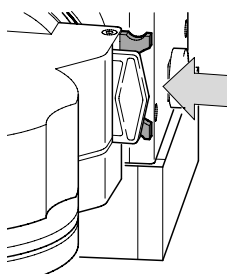

Filter slide

Next to the light stop is a slot accepting a filter slide which can hold an individually-selectable filter, e.g. a grey filter.

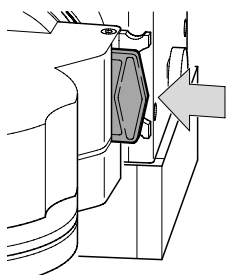

Working without the fluorescence illuminator

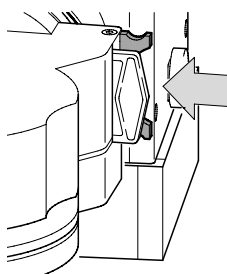

- ▶ Use the light stop to block the light from the fluorescence illuminator.

- ▶ Turn the dummy filter carrier in the observation beam path so that there is no barrier filter in position which might cause false colour.

Use

MZ10 F: Bringing the specimen into focus and observing it



Observe the safety directions on page 4 and the recommendations on page 5 regarding the use of the mercury-vapour lamp.

Changing filters

In the rapid filter changer, all four positions must be occupied, either with filter sets or with dummy filter carriers (see page 16). The active filter set is always the one with its inscription on the left.

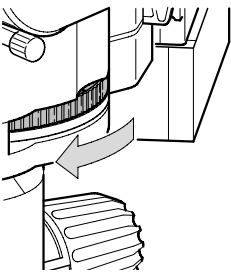

- ▶ Turn the sets of filters until the inscription on the one required is visible on the left.

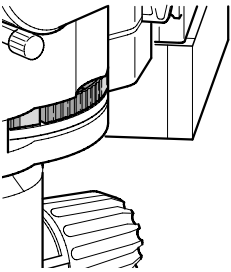

Dioptric correction

We recommend you to carry out the dioptric correction either in transmitted light or in incident light:

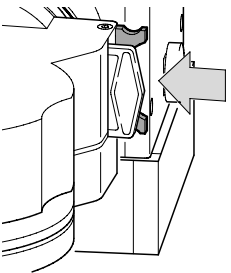

- ▶ If the fluorescence illuminator is switched on, use the light stop to block the light (page 16).

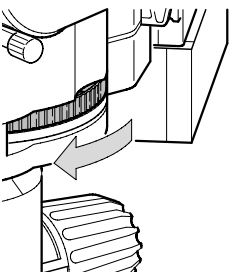

- ▶ Swing the dummy filter carrier into the beam path (page 16).

- ▶ Illuminate a flat test object with transmitted light or with oblique incident light.
- ▶ Carry out the dioptric correction as directed in the user manual for the stereomicroscope.

Observing fluorescence



Make sure that the UV protection screen is positioned correctly (page 11).

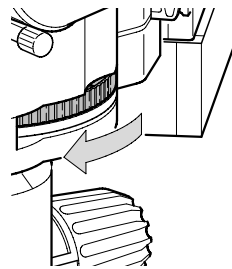
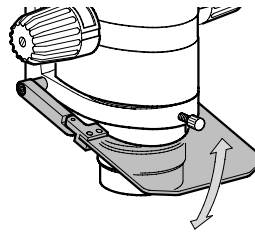

- ▶ Turn the required filter set into the beam path (page 16).

- ▶ Switch on the supply unit (pages 14) and wait for two or three minutes.

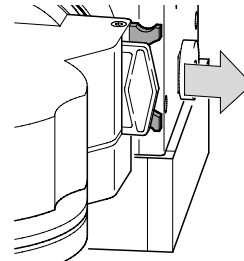

- ▶ Pull out the light stop (page 16).

- ▶ Using the lowest magnification, observe the object.
- This will give you a better overall view and you will be able to locate features of interest more easily.
- ▶ Refocus slightly if necessary.
- ▶ Observe the details at higher magnification.

Reflexes (hot-spots)

When the 1.6× planapochromatic objective is used at zoom positions between 0.8 and 1.6, a slight reflex (hot-spot) occurs in the lower part of the field of view; it disappears at higher zoom positions. This reflex does not arise in conjunction with the 1.0× and 0.5× planapochromatic objectives or the achromatic objectives.

Overview

Outfit with stereo-fluorescence module

The components

- 1 Choice of stand and of focusing drive (manual or motor-driven)
- 2 Microscope carrier
- 3 Leica MS5, MZ6, MZ7.5 – 16 optics carrier
- 4a Leica stereo-fluorescence module with choice of barrier filter
- 4b Filter insert for excitation filter
- 4c Light stop
- 4d Filter holder with an individually-selectable filter
- 4e Adapter for light source
- 5a Leica 106Z lamp housing for 50W or 100W mercury-vapour burners
- 5b Stray-light protection
- 6 Supply unit for 50W or 100W mercury-vapour burner (not illustrated)
- 7 UV-light excluder with arm and clamp
- 8 Double-iris diaphragm (optional)
- 9 Choice of binocular tube, or optional video-/phototube

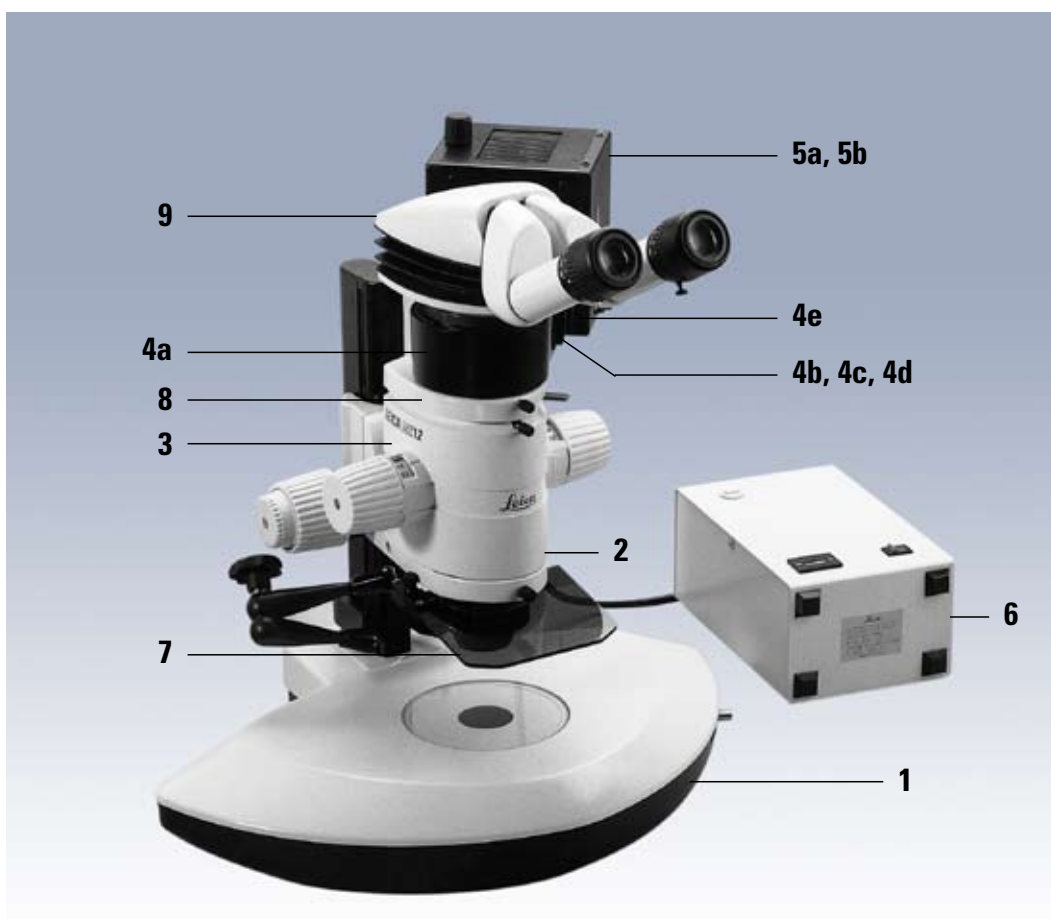

Filter sets for stereo-fluorescence module

Filter sets	Excitation filters	Dichromatic beam splitters	Barrier filters
GFP fluorescence	425/60nm	470nm	GG475
GFP-Plus fluorescence	480/40nm	505nm LP	510nm LP
GFP-Plant	470/40nm	495nm	525/50nm
UV fluorescence	360/40nm	400nm	GG420
Violet fluorescence	425/40nm	460nm	GG475
Blue fluorescence	470/40nm	505nm	OG515
Green fluorescence	546/10nm	565nm	OG590

Assembly

Stereo-fluorescence module

- 1 Incident- or transmitted-light base
- 2a Manual focusing drive, or
- 2b Motorized focusing drive
- 3 Microscope carrier
- 4 Choice of optics carrier
- 5 Fluorescence module
- 6a 106Z lamp housing
- 6b Stray-light protection

- 7 Binocular tube
- 8 Clamp
- 9 Arm
- 10 UV-light excluder
- 11 Filter carrier
- 12 Filterholder for excitation filter
- 13 Light stop
- 14 Filter carrier with an individually-selectable filter
- 15 Double-iris diaphragm (optional)
- 16 HU video-/phototube (optional)

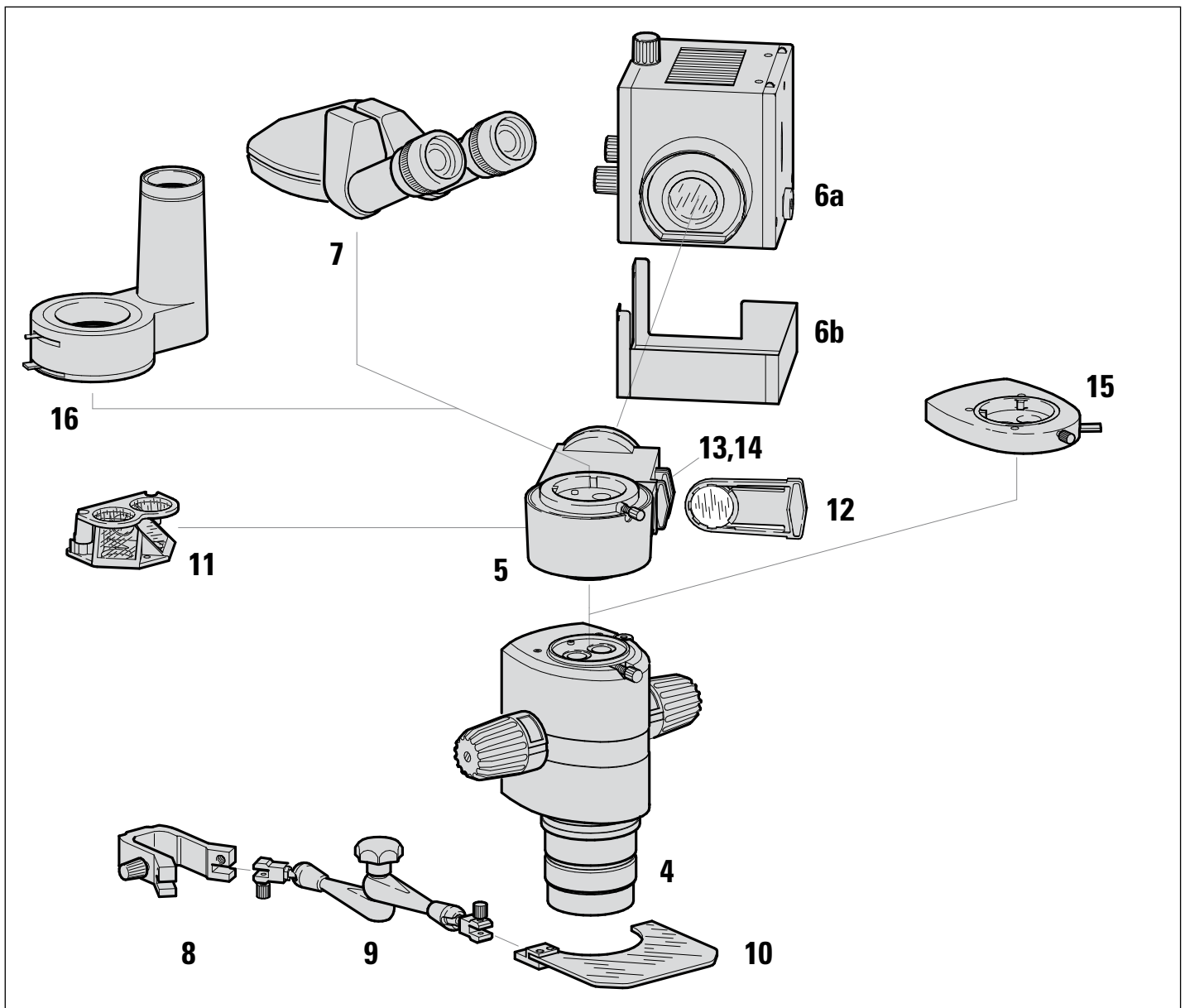

Stereo-fluorescence module

Focusing drive → base of stand

- ▶ Connect manually-operated or motor-driven focusing drive, complete with column, to base, as described in user manual M2-105-0EN.



Before using the motor focus, you must read the safety directions in the accompanying user manual M2-267-104.

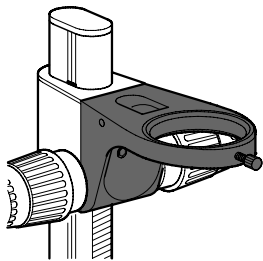

For the Leica stereomicroscope models MS5, MZ6, MZ8, MZ12, MZAPO with manual focusing drive, fit the microscope in the upper position on the focusing drive (refer to user manual for stereomicroscope).

Fluorescence module → stereomicroscope

- Assemble in the following order without double-iris diaphragm: Optics carrier, fluorescence module, binocular tube or phototube
- Assemble in the following order with double-iris diaphragm: Optics carrier, double-iris diaphragm, fluorescence module, binocular tube or phototube
- ▶ Align the fluorescence module on the optics carrier so that the adapter for the lamp housing points backwards at about 45°
- ▶ Continue assembling in accordance with the user manual for the stereomicroscope (see section "Fitting accessory tubes")

Video-/phototubes

The fluorescence illumination is directed along the left-hand beam path and could cause hot-spots in the image. Therefore:

- ▶ Position the HU phototube over the right-hand beam path.

Changing the filter set

Removable filter sets that can hold various filters are available for the fluorescence module. A filter set consists of a filter carrier with barrier filter and of a filterholder with excitation filter. If you wish to change the filter set while you are in the middle of a task, leave the illuminator switched on so that you will not have to wait for the lamp to cool (page 12) before continuing.

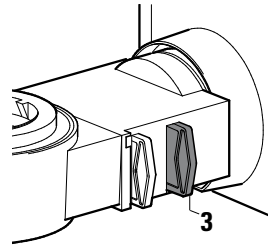

Important: With the illuminator on, insert the filterholder with diaphragm into slide-in unit 3 to avoid being suddenly exposed to excessively bright light (page 22).

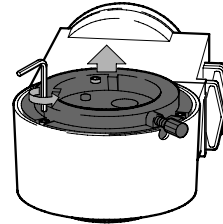

- ▶ Remove the binocular tube.
- ▶ Loosen the 3 socket-head screws.
- ▶ Remove the cover.

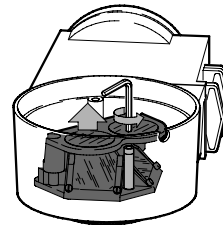

- ▶ Loosen the fastening screw and take out the filter carrier.

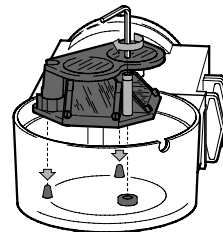

- ▶ Insert the desired filter carrier. Fit both of the two guide pins in the fluorescence module into the holes on the filter carrier.
- ▶ Tighten the fastening screw securely.

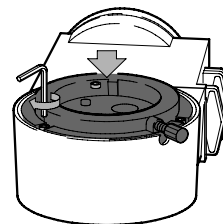

- ▶ Replace the cover and tighten the 3 socket-head screws securely.

- ▶ Replace the binocular tube.
- ▶ Insert a suitable exciter filter (page 22).
- ▶ Take out the filterholder with diaphragm.
- ▶ Re-adjust the light source (page 15).

Assembly

Stereo-fluorescence module

UV-light excluder → side-faced column



Always position the UV-light excluder so that the user never looks directly at the light spot (page 5).

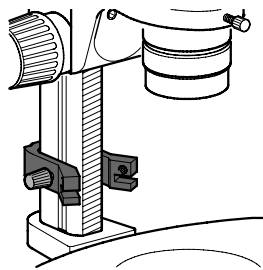

- ▶ Using the clamping screw, secure the clamp on the side-faced column, beneath the focusing drive.



- ▶ Slacken the central fixing screw.
- ▶ Unfold the arm.
- ▶ Tighten the central fixing screw.

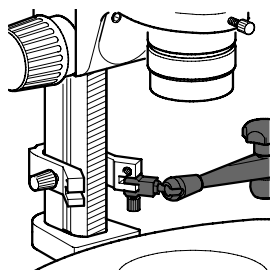

- ▶ Secure the arm, complete with connector, to the clamp, on the left or right. Tighten the clamping screw.

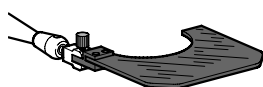

- ▶ Secure the UV-light excluder to the arm. Tighten the clamping screw.

Filterholder → fluorescence module

The dichromatic beam splitter and the barrier filter are built into the fluorescence module in accordance with the configuration (see table, page 19).

The excitation filter is supplied in a separate filterholder.

A filterholder with diaphragm is also supplied. This diaphragm can be slid into the illumination beam path if the object should not be illuminated.

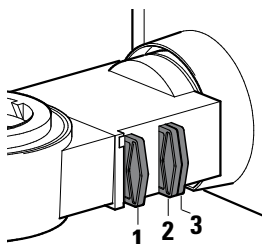

The filter slide on the fluorescence module has space for three filterholders:

- with excitation filter (holder 1)
- with diaphragm (holder 3)
- with individually-selectable filter, e.g. neutral filter (holder 2).

Double-iris diaphragm

The double-iris diaphragm is used to increase the depth of field (see user manual M2-105-0EN). Also, the stray reflections arising in the left-hand beam path can be minimized with the help of the double-iris diaphragm.

The HU video-/phototube already includes a double-iris diaphragm.

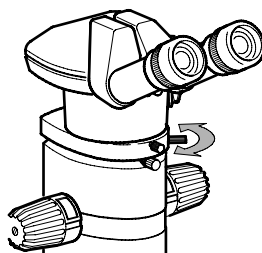

Additional assembly instructions

Lamp housing	pages 12–13
Supply units	page 14
Adjusting the mercury-vapour lamp	page 15

Use

Stereo-fluorescence module

Focusing and observing



Observe the safety regulations on page 4 and note the recommendations on page 5 for using the mercury-vapour burner. Position the UV-light excluder correctly (see page 22):

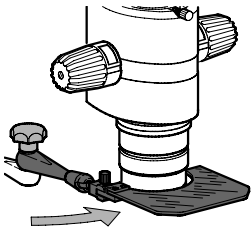

- ▶ Hold the arm
- ▶ Release the central clamping screw
- ▶ Position the UV-light excluder in front of the objective
- ▶ Tighten the central clamping screw.

Focusing

Carry out the dioptric correction and the focusing in accordance with the user manual for the stereomicroscope, either:

in transmitted light:

- ▶ pushing in the filter holder with diaphragm (3) to block the fluorescence illumination (see page 22). Pull the filter holder with diaphragm out again before observing the fluorescence.

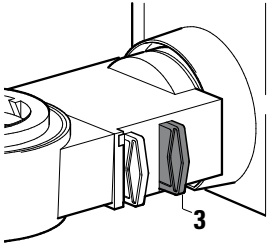

with the fluorescence illumination:

- ▶ pulling out the filter holder with diaphragm (3) (see page 22)
- ▶ Insert the excitation filter (1) (page 22)

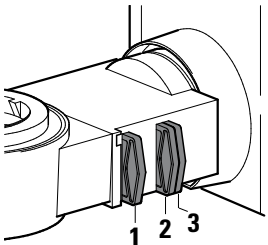

- ▶ Switch on the supply unit (page 14). For the 100W lamp, wait two or three minutes for the whistle signal.

Observation

- ▶ First use the lowest magnification to observe the object
- You will gain a better overall view and can more easily find interesting features
- ▶ Refocus slightly if necessary
- ▶ Observe details at a higher magnification.

Leica Microsystems – the brand for outstanding products

Leica Microsystems' mission is to be the world's first-choice provider of innovative solutions to our customers' needs for vision, measurement and analysis of micro-structures.

Leica, the leading brand for microscopes and scientific instruments, developed from five brand names, all with a long tradition: Wild, Leitz, Reichert, Jung and Cambridge Instruments. Yet Leica symbolizes innovation as well as tradition.

Leica Microsystems – an international company with a strong network of customer services.

Australia:	Gladesville	Tel. +61 2 9879 9700	Fax +61 2 9817 8358
Austria:	Vienna	Tel. +43 1 486 80 50 0	Fax +43 1 486 80 50 30
Canada:	Richmond Hill/Ontario	Tel. +1 905 762 2000	Fax +1 905 762 8937
Denmark:	Herlev	Tel. +45 4454 0101	Fax +45 4454 0111
France:	Rueil-Malmaison	Tel. +33 1 47 32 85 85	Fax +33 1 47 32 85 86
Germany:	Bensheim	Tel. +49 6251 136 0	Fax +49 6251 136 155
Italy:	Milan	Tel. +39 0257 486.1	Fax +39 0257 40 3475
Japan:	Tokyo	Tel. + 81 3 5421 2800	Fax +81 3 5421 2896
Korea:	Seoul	Tel. +82 2 514 65 43	Fax +82 2 514 65 48
Netherlands:	Rijswijk	Tel. +31 70 4132 100	Fax +31 70 4132 109
People's Rep. of China:	Hong Kong	Tel. +852 2564 6699	Fax +852 2564 4163
Portugal:	Lisbon	Tel. +351 21 388 9112	Fax +351 21 385 4668
Singapore		Tel. +65 6779 7823	Fax +65 6773 0628
Spain:	Barcelona	Tel. +34 93 494 95 30	Fax +34 93 494 95 32
Sweden:	Sollentuna	Tel. +46 8 625 45 45	Fax +46 8 625 45 10
Switzerland:	Heerbrugg	Tel. +41 71 726 34 33	Fax +41 71 726 34 44
United Kingdom:	Milton Keynes	Tel. +44 1908 246 246	Fax +44 1908 609 992
USA:	Bannockburn/Illinois	Tel. +1 847 405 0123	Fax +1 847 405 0164

and representatives of Leica Microsystems in more than 100 countries.

In accordance with the ISO 9001 certificate, Leica Microsystems (Switzerland) Ltd, Business Unit Stereo & Macroscopic Systems has at its disposal a management system that meets the requirements of the international standard for quality management. In addition, production meets the requirements of the international standard ISO 14001 for environmental management.

The companies of the Leica Microsystems Group operate internationally in three business segments, where we rank with the market leaders.

• Microscopy Systems

Our expertise in microscopy is the basis for all our solutions for visualization, measurement and analysis of micro-structures in life sciences and industry. With confocal laser technology and image analysis systems, we provide three-dimensional viewing facilities and offer new solutions for cytogenetics, pathology and materials sciences.

• Specimen Preparation

We provide comprehensive systems and services for clinical histo- and cytopathology applications, bio-medical research and industrial quality assurance. Our product range includes instruments, systems and consumables for tissue infiltration and embedding, microtomes and cryostats as well as automated stainers and coverslippers.

• Medical Equipment

Innovative technologies in our surgical microscopes offer new therapeutic approaches in microsurgery.

Winner 2005

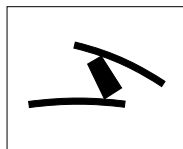

Innovationspreis
der deutschen Wirtschaft
The World's First Innovation Award

www.leica-microsystems.com

Leica

MICROSYSTEMS